

Electromechanical Cylinder EMC-HD



Identification system for short product names

Short product name		Example:	EMC	-	085	-	HD	-	1
System	=	<u>E</u> lectro <u>M</u> echanical <u>C</u> ylinder							
Size		085 / 125							
Version	=	<u>H</u> eavy <u>D</u> uty							
Generation	=	Product generation 1							

Contents

Product Description and Technical Data	4
Product Description	4
Product Selection Guide	6
Motor-Controller Combination	10
Load Ratings and Sizes	11
Structural Design	12
Technical Data	14
<hr/>	
Calculations	20
Calculation Principles	20
Sizing the Drive	22
<hr/>	
EMC-085-HD	26
EMC-085-HD – Configuration and Ordering	26
EMC-085-HD – Dimension Drawings	30
EMC-085-HD – Motor Attachments	32
<hr/>	
EMC-125-HD	34
EMC-125-HD – Configuration and Ordering	34
EMC-125-HD – Dimension Drawings	38
EMC-125-HD – Motor Attachments	40
<hr/>	
Attachments and Accessories	42
Mounting Elements	42
Load Sensor	54
Switch Mounting Arrangements	56
IndraDyn S – Servo Motors MSK	58
<hr/>	
Services and Information	60
Operating Conditions and Usage	60
Nameplate	61
Lubrication and Maintenance	62
Documentation	63
Further Information	64
Ordering Example EMC-125-HD	66
Inquiry or Order	71
Glossary (definitions)	72

Product Description

Positioning loads weighing tons to the micrometer, pressing, joining or closing powerfully while varying the motion sequence as required: the new Electromechanical Cylinders EMC Heavy Duty (EMC-HD) from Rexroth exploit the advantages of modern control technology even at high forces.

The high rigidity of the units allows precise positioning in addition to high performance and dynamics. Users can seamlessly integrate the cylinders into intelligent energy management and in this way reduce power consumption and carbon emissions.

Parameters for force, position and travel speed can be set as required and flexibly adapted to new tasks at any time via the drive system. The Electromechanical Cylinders EMC-HD for heavy loads transmit the motor movement via ball or planetary screw assemblies depending on the requirements on dynamics and force. Available in various sizes and leads the highly precise Rexroth screw drives cover a wide range of needs cost-effectively. Rexroth offers the EMC-HD as ready-to-install, purely mechanical axes and as a complete system with a choice of precisely matched gear units, servo motors and drive controllers from the IndraDrive series.

Structural design

The mechanical system in the Electromechanical Cylinders EMC-HD Heavy Duty is based on proven planetary or ball screw assemblies in a wide range of diameter and lead combinations. A screw drive converts torque into linear motion with high mechanical efficiency. During this process the piston rod fastened to the screw drive nut is extended and retracted. Both the nut and the piston rod are guided in the housing.

The piston rod-to-housing interface is optimally sealed to prevent dirt from working its way in. The complete cylinder is compliant with protection class IP 65.

The EMC-HD is available with or without a piston rod anti-twist feature. The integrated anti-twist feature is realized by means of four guide surfaces on the piston rod and a sliding guide in the housing.

Integrated end position buffers protect the mechanical system during start-up. Switches are available as an option. Limit switches prevent damage to the cylinder in operation. A reference point switch is available for the use of incremental encoder systems.

Electromechanical Cylinders EMC-HD require only minimal maintenance effort. The advantage of grease lubrication is that the screw drive can run long distances on one supply of grease.

Advantages

- ▶ High energy efficiency and little pollution (no risk of leaks)
- ▶ Straightforward, compact and robust structural design for space-saving integration in machine concepts and usage even in harsh environmental conditions
- ▶ Complete building system with multiple combination options for high flexibility to serve a broad range of applications
- ▶ Precise positioning, high dynamics, powerful drive and long service life due to the use of highly precise Rexroth planetary and ball screw assemblies
- ▶ Smart, freely programmable drive system allowing the realization of complex travel profiles (parameters for force, position and travel speed can be set as required over the complete working travel range)



Application areas

Electromechanical Cylinders EMC-HD can be used in many application areas. Due to their specific characteristics, they offer advantages in terms of accuracy, dynamics and controllability, and can therefore not only help to shorten cycle times but also to increase flexibility and quality in the manufacturing process. Their compact design makes them ideal for use in restricted space envelopes.

Possible application areas are:

- ▶ Servo presses and forming technology
- ▶ Joining technology
- ▶ Thermoforming
- ▶ Injection molding and blow molding machines
- ▶ Woodworking machines
- ▶ Machine tools
- ▶ Assembly and handling technology
- ▶ Packaging machines and conveyor systems
- ▶ Testing equipment and laboratory applications
- ▶ Simulators
- ▶ Special-purpose machines

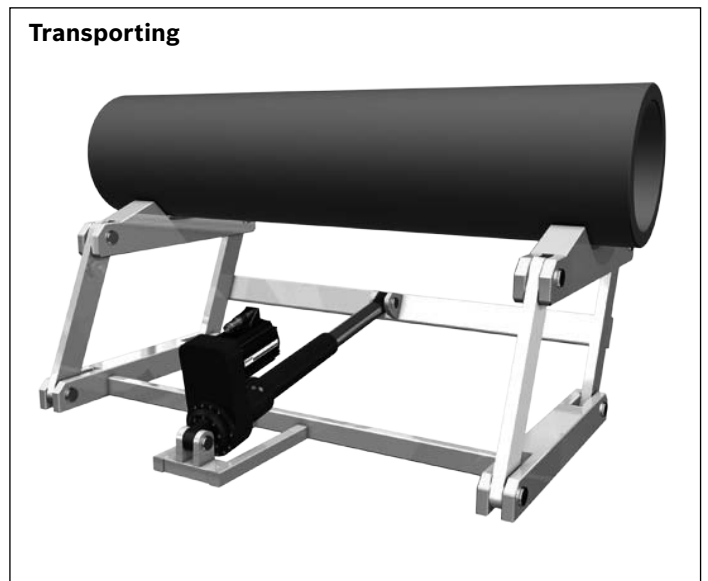
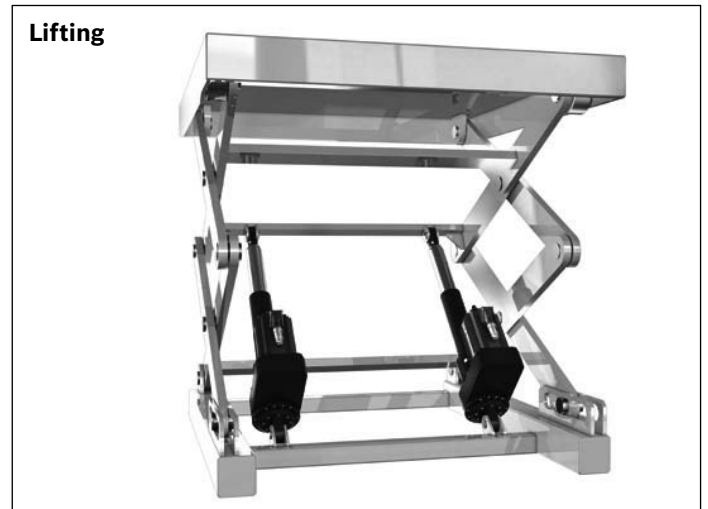
Application examples

Product Selection Guide

To make sure your electromechanical solution delivers optimal performance, both technically and economically, the right decisions have to be made as early as the planning phase. The following key parameters have a decisive influence on the choice of system and its structural design:

- ▶ Load
- ▶ Dynamics
- ▶ Geometry
- ▶ Environmental and installation conditions

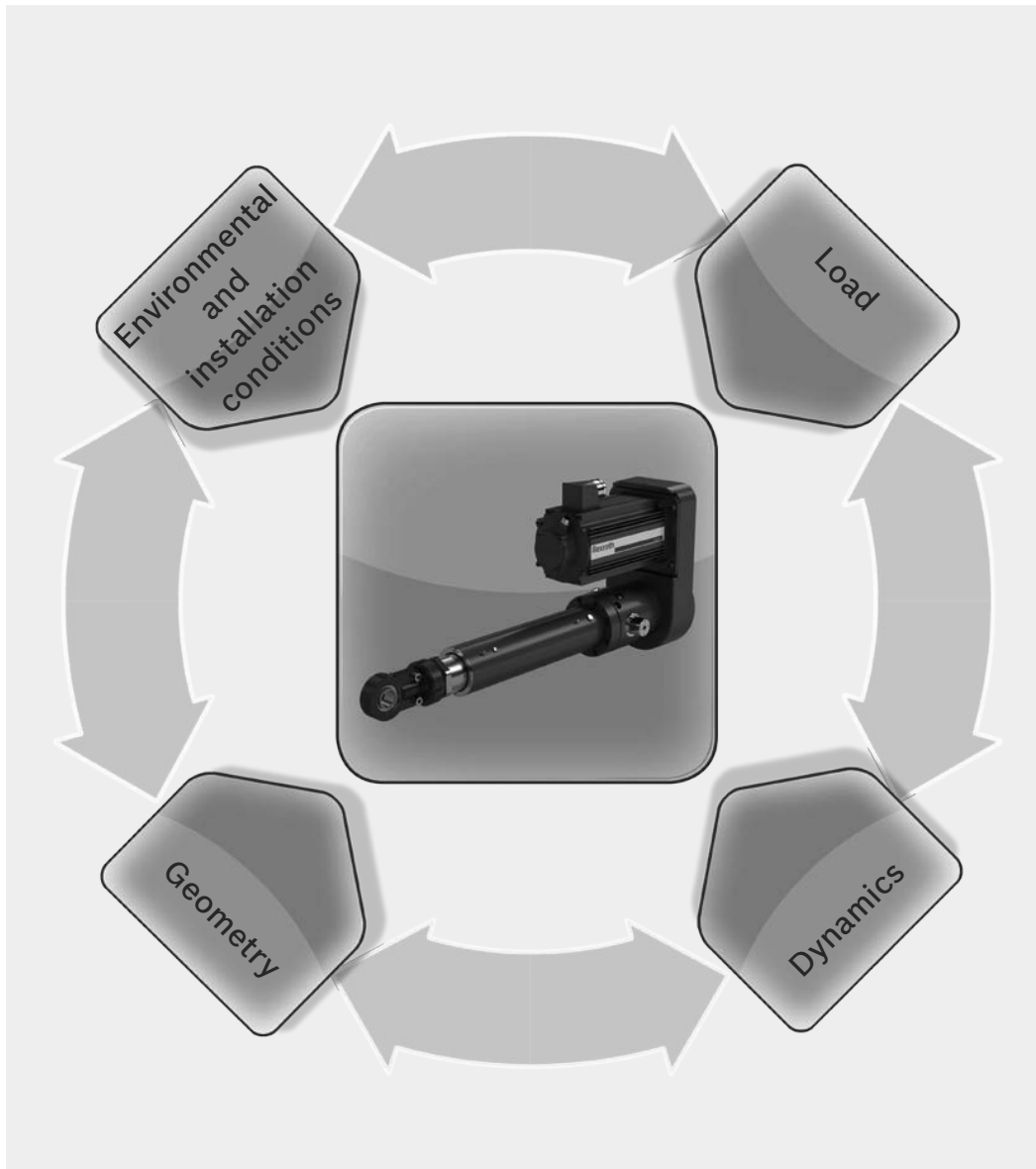

Load

- ▶ Process force
- ▶ Masses
- ▶ Duty cycle
- ▶ Service life requirement
- ▶ etc.

Dynamics

- ▶ Acceleration
- ▶ Linear speed
- ▶ Cycle time
- ▶ etc.

Geometry

- ▶ Work space
- ▶ Installation space
- ▶ Stroke length
- ▶ Interference contours
- ▶ etc.

Environmental and installation conditions

- ▶ Mounting orientation
- ▶ Fastening options
- ▶ Degrees of freedom
- ▶ Temperature
- ▶ Humidity
- ▶ Contamination
- ▶ Vibration and shocks
- ▶ etc.

An Electromechanical Cylinder EMC-HD that matches your needs in just six steps

Electromechanical Cylinders EMC-HD offer higher dynamics and precision, better controllability and greater mechanical efficiency than the majority of fluid-power drives (e.g. hydraulic cylinders). Because of to their special characteristics in comparison with fluid-driven technology, it is particularly important to completely define the requirements of the application in advance. To find the most cost-efficient solution for your application, the following input parameters should be known:

1. Loads

An EMC-HD solution that is both economical and reliable can be found when the loads (process forces and masses) are known as accurately as possible. Along with the maximum force in the application, it is important to also state changing forces over the stroke so that the average load over the entire cycle can be determined. This average load forms the basis for the nominal life calculation.

Large safety factors on the force required, as are common in some fluid-power applications, should be avoided so that the axis is not over-sized. A differentiation is also to be made between static load (cylinder at standstill) and dynamic load (during the feed motion).

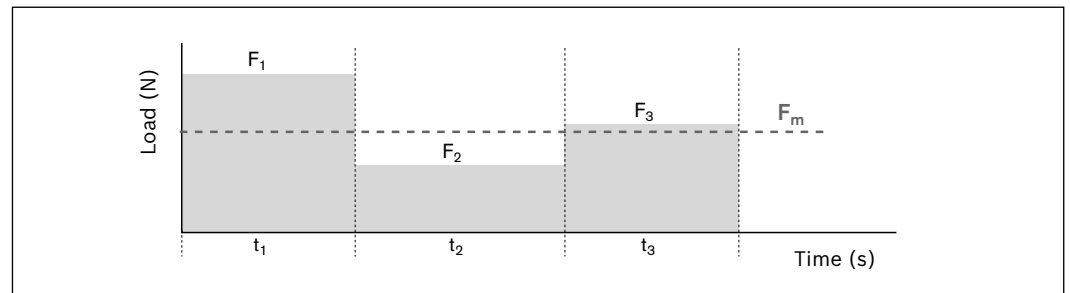

2. Duty cycle

The duty cycle is the ratio of the operating time to the total cycle time expressed in percent. The duty cycle is an important input parameter for both the estimation of the total service life of the cylinder and for the thermal assessment of cylinder and motor. Pause times should always also be stated for the calculation.

$$DC = \frac{t_o}{t_o + t_p} \cdot 100\%$$

- DC = duty cycle (%)
- t_o = operating time (s)
- t_p = pause time (s)

Product Selection Guide

3. Total cycle

By stating as accurately as possible the accelerations and linear speeds or, alternatively, the necessary cycle time and the travel, it is possible to adapt the complete drive train to maximize results for the application. The type of screw drive, lead, gear reductions and drive can be selected such that the requirements are met precisely and efficiently.

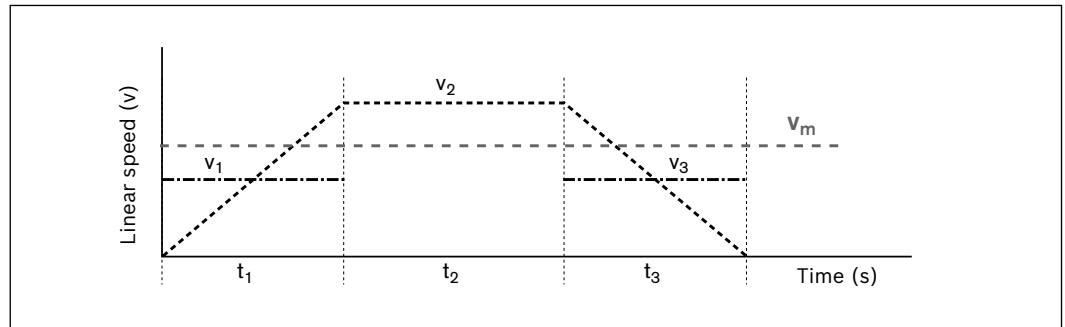

4. Integration in the machine

Transverse forces on the piston rod and alignment errors during installation can shorten the service life of the Electromechanical Cylinder EMC-HD.

During mounting it must be ensured the cylinder is installed free of distortive stresses and any transverse loads are absorbed by an external guideway. Depending on whether the drive torque is to be absorbed in the cylinder or via an external guideway, the cylinder can be ordered with or without an integrated anti-twist feature. (For further information on the anti-twist feature see the “Structural design” section).

5. Travel and overall dimensions

Determine the necessary operating stroke in your application. As Electromechanical Cylinders EMC-HD must not be allowed to travel right up to the mechanical end stop, it is important to add excess travel (s_e) to both ends of the effective operating stroke (s_{eff}). This maximum travel (s_{max}) is the parameter to be stated when ordering the cylinder.

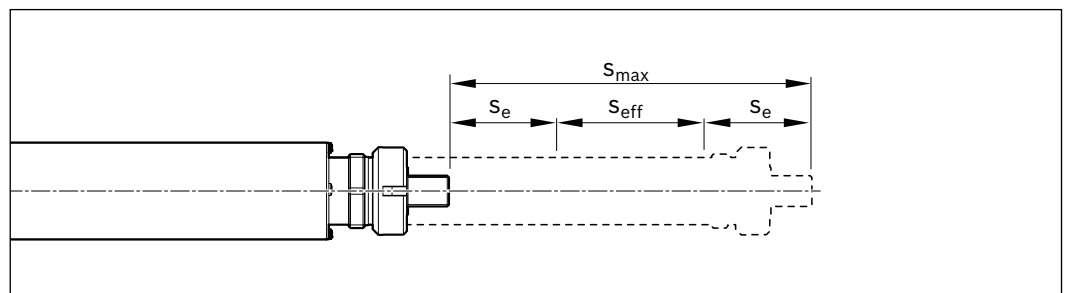

For structural design reasons the overall length of the cylinder is greater than the maximum travel (s_{\max}), as it includes the length of components such as the screw drive nut or the bearings, in addition to the travel.

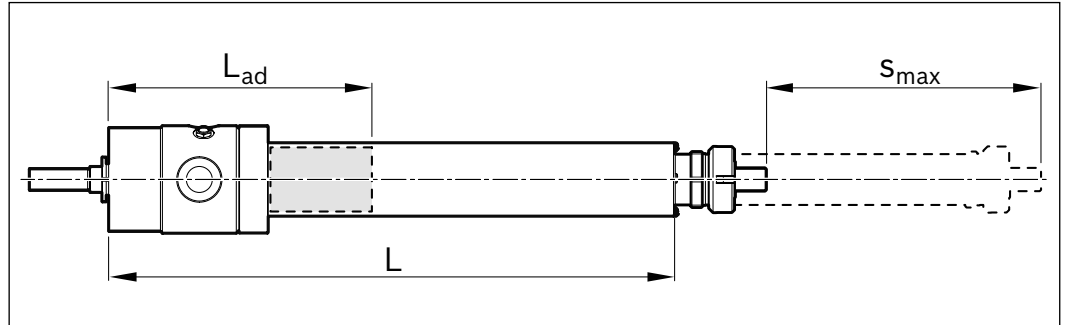

The cylinder can be adapted to the available installation space by mounting the motor as an extension to the axis (motor mount and coupling) or parallel to the axis (timing belt side drive). The type of motor attachment chosen also has an effect on the technical performance data and the selectable mounting methods.



6. Environmental conditions

The environment in which a cylinder is operated can have a significant effect on its service life. Both very high and very low temperatures can affect seals, lubrication and the performance of the motor. Abrasive dirt and chemicals can damage the seals and ultimately cause the screw drive to fail over the long term.

Please ask if there are special environmental conditions in your application.

Motor-Controller Combination

Several motor-controller combinations are available in order to provide the most cost-effective solution for every customer application. When sizing the drive, always consider the motor-controller combination.

Notes on motors and controllers

- ▶ The motors can be supplied complete with controllers and control systems
- ▶ For recommended motor-controller combinations, see the “Servo Motors” section

Catalogs and information

- ▶ Drive System Rexroth IndraDrive, R999000018
- ▶ Rexroth IndraDyn S Synchronous Motors MSK, R911296288
- ▶ Rexroth IndraDrive C Drive Controllers with HCS02 and HCS03, R911314904

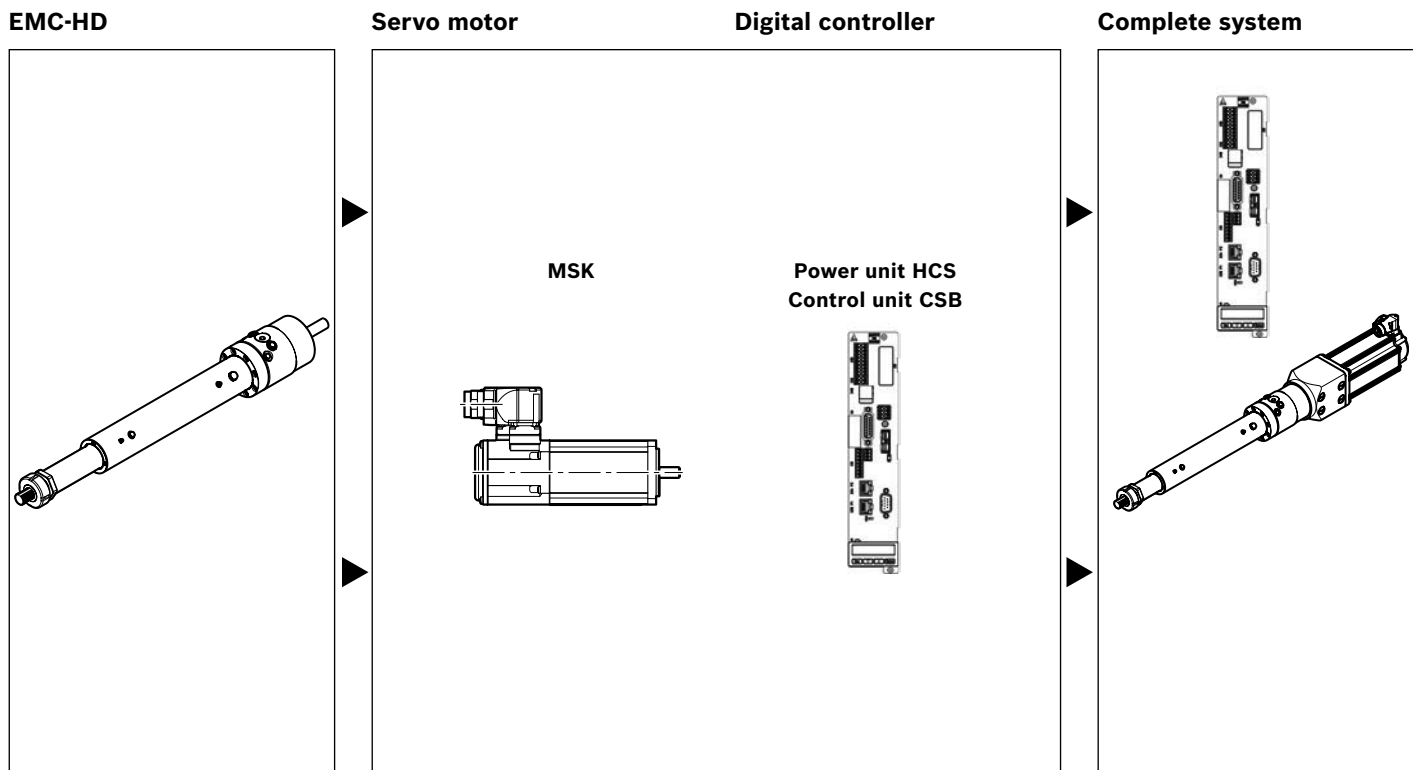

Load Ratings and Sizes

Note on dynamic load ratings

In relation to the desired service life, in general an equivalent dynamic axial load of up to about 20% of the dynamic load rating (C) has proved appropriate.

(See also service life graphs in the “Technical Data” section.)

- ▶ Here the following must not be exceeded:
 - The maximum permissible drive torque
 - The maximum permissible load
 - The maximum permissible linear speed
 - The maximum permissible acceleration

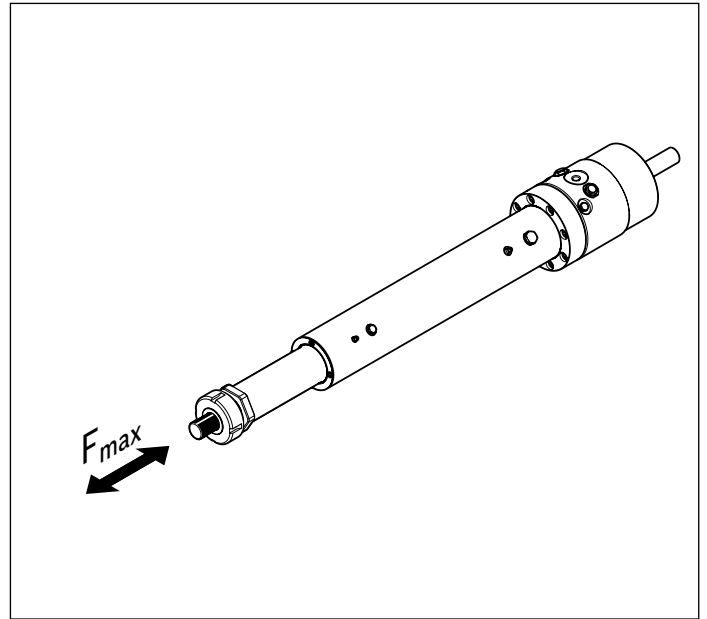

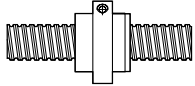
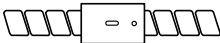
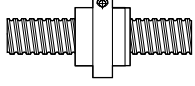
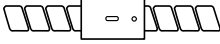
Electromechanical Cylinder	Drive	$d_0 \times P$	C (N)	F_{max} (N)	$s_{max\ perm}$ (mm)	v_{max} (m/s)
EMC-085-HD	PLSA 	30x5	87 000	44 000	700	0.42
		30x10	98 000	44 000		0.83
	BS 	40x10	72 000	44 000		0.63
		40x20	95 000	38 000		1.00
EMC-125-HD	PLSA 	48x5	188 000	95 000	1 200	0.26
		48x10	211 000	110 000		0.52
	BS 	63x10	88 000	88 000		0.40
		63x20	130 000	85 000		0.80

- C = dynamic load rating
- d_0 = diameter of screw drive
- F_{max} = maximum permissible axial force
- BS = Ball Screw Assembly
- PLSA = Planetary Screw Assembly
- P = screw drive lead
- $s_{max\ perm}$ = maximum permissible linear travel
- v_{max} = maximum linear speed

Structural Design

- 1** Threaded mounting interface¹⁾
- 2** Wrench flats³⁾
- 3** Piston rod²⁾
- 4** Lube nipple
- 5** Housing¹⁾
- 6** Bearing housing¹⁾
- 7** Drive journal⁴⁾
- 8** Lock nut

Attachments

- 9** Motor mount and coupling
- 10** Motor
- 11** Gear reducer
- 12** Timing belt side drive

- 1)** Steel, black galvanized, black painted as an option
- 2)** Steel, chromium plated
- 3)** Only on version "without anti-twist feature"
- 4)** Steel

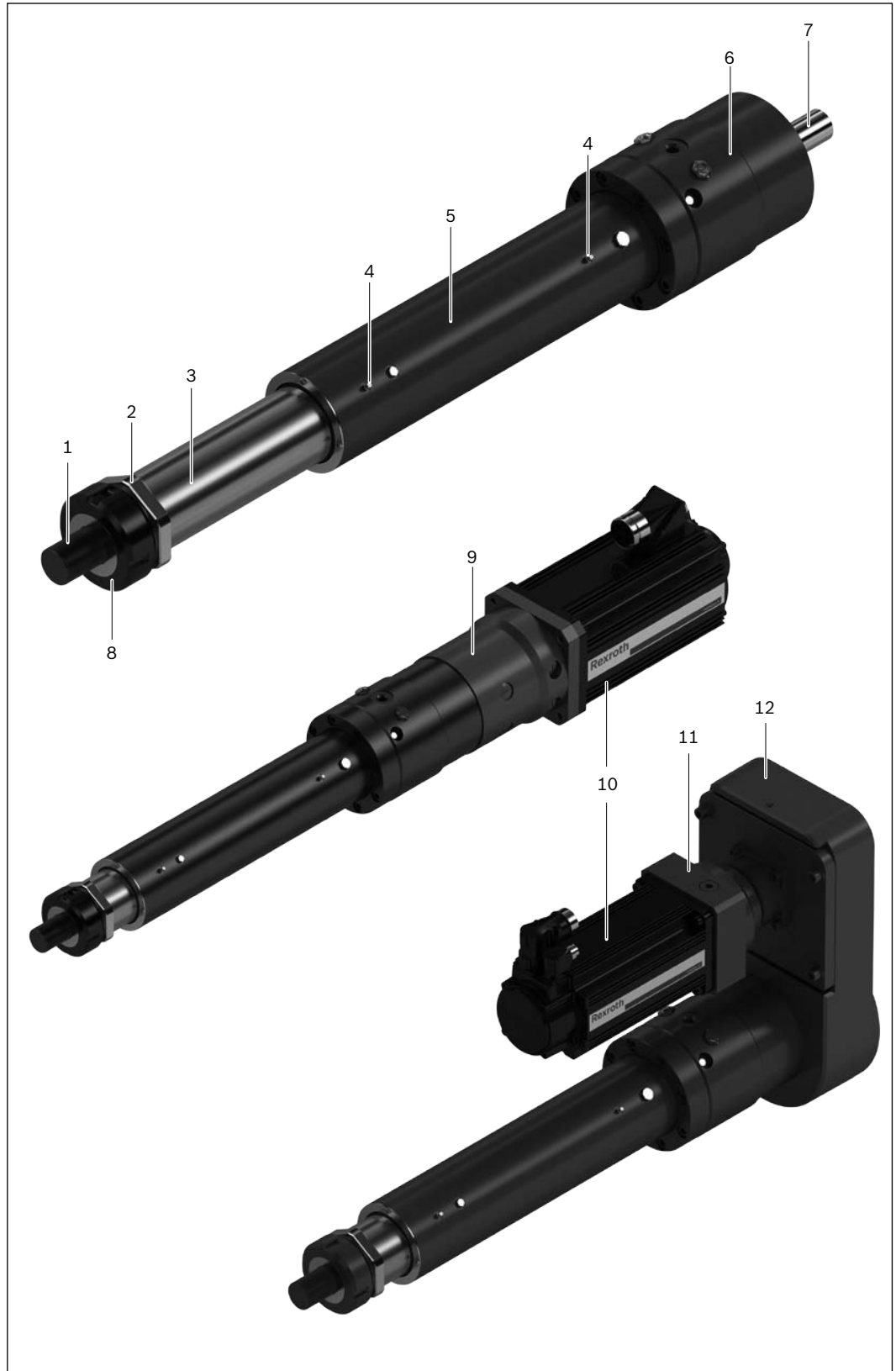

Version with Planetary Screw Assembly PLSA**Version with Ball Screw Assembly BS****Guide without integrated anti-twist feature****Guide with integrated anti-twist feature****Screw drive**

The EMC-HD is available with a planetary or ball screw assembly.

- ▶ In the case of planetary screw assemblies, several planets are positioned in a rotationally symmetric manner inside a nut. They rotate parallel to the axis of a screw and generate linear motion. The numerous contact areas inherent in this system design result in high axial rigidity and load-bearing capacity and thus provide for a long service life. Planetary screw assemblies achieve very high positioning accuracy and repeatability even in case of minimal traversing movements.
- ▶ In ball screw assemblies, balls provide the rolling contact. The high leads allow for highly dynamic applications while assuring high mechanical efficiency so that little heat is generated. The low lubricant consumption ensures service intervals are long. The use of multi-start screws and a large number of ball track turns in the ball nut results in high load ratings and therefore a long service life.

Anti-twist feature

The EMC-HD is available with or without a piston rod anti-twist feature.

- ▶ On the cost-optimized basic version without anti-twist feature, the piston rod can still be twisted during installation and as a result easily extended and retracted manually. To ensure correct linear motion in operation, the piston rod must be secured externally against twisting (e.g. by fastening it to a linear guide). The torque to be absorbed corresponds to the drive torque at the drive journal of the screw drive (see the “Design calculations” section).
- ▶ The integrated anti-twist feature is used if external absorption of the torque is not possible (e.g. when space is limited or if the piston rod extends freely into the working zone). The anti-twist feature is realized by means of four guide surfaces on the piston rod and a sliding guide at the head end of the housing.

Technical Data

Dimensions, load capacities, maximum forces and masses

Size	PLSA	BS	C	F _{max}	s _{min}	s _{max perm} ¹⁾	L _{ad}	m _s		m _{ca}	
	d ₀ xP (mm)	d ₀ xP (mm)						k _{g fix} (kg)	k _{g var} (kg/mm)	m _{ca fix} (kg)	m _{ca var} (kg/mm)
EMC-085-HD	30x5	-	87 000	44 000	85	700	352	30	0.030	6.2	0.011
	30x10	-	98 000	44 000	85	700	352	30	0.030	6.2	0.011
	-	40x10	72 000	44 000	110	700	352	30	0.033	6.2	0.011
	-	40x20	95 000	38 000	230	700	370	30	0.033	6.2	0.011
EMC-125-HD	48x5	-	188 000	95 000	130	1 200	442	70	0.060	16.5	0.025
	48x10	-	211 000	110 000	130	1 200	442	70	0.060	16.5	0.025
	-	63x10	88 000	88 000	170	1 200	405	70	0.068	16.5	0.025
	-	63x20	130 000	85 000	230	1 200	427	70	0.068	16.5	0.025

¹ For non-standard distances please contact Bosch Rexroth.

Mass of the EMC-HD

Weight calculation without motor and without motor attachment

$$m_s = k_{g \text{ fix}} + k_{g \text{ var}} \cdot S_{\text{max}}$$

Weight calculation without motor with timing belt side drive including gear unit (optional)

$$m_s = k_{g \text{ fix}} + k_{g \text{ var}} \cdot S_{\text{max}} + m_{\text{sd}}$$

Weight calculation without motor with motor mount and coupling including gear unit (optional)

$$m_s = k_{g \text{ fix}} + k_{g \text{ var}} \cdot S_{\text{max}} + m_c$$

Moved mass of system

$$m_{\text{ca}} = m_{\text{ca fix}} + m_{\text{ca var}} \cdot S_{\text{max}}$$

Length calculation

$$L = S_{\text{max}} + L_{\text{ad}}$$

- | | | | | | |
|--------------------|--|---------|-----------------------|---|---------|
| C | = dynamic load capacity | (N) | m _{ca fix} | = constant for the fixed-length portion of the moved mass of system | (kg) |
| d ₀ | = diameter of screw drive | (mm) | m _{ca var} | = constant of the variable-length portion of the moved mass of system | (kg/mm) |
| F _{max} | = maximum permissible axial force | (N) | m _s | = mass of EMC-HD | (kg) |
| BS | = Ball Screw Assembly | | m _{sd} | = mass of timing belt side drive | (kg) |
| k _{g fix} | = constant for the fixed-length portion of the mass | (kg) | P | = screw drive lead | |
| k _{g var} | = constant for the variable-length portion of the mass | (kg/mm) | PLSA | = Planetary Screw Assembly | |
| L | = overall length (without piston rod) | (mm) | s _{min} | = minimum travel | (mm) |
| L _{ad} | = additional length | (mm) | s _{max} | = maximum travel | (mm) |
| m _c | = mass of motor mount and coupling | (kg) | s _{max perm} | = maximum permissible travel | (mm) |
| m _{ca} | = moved mass of system | (kg) | | | |

Service life

EMC-085-HD

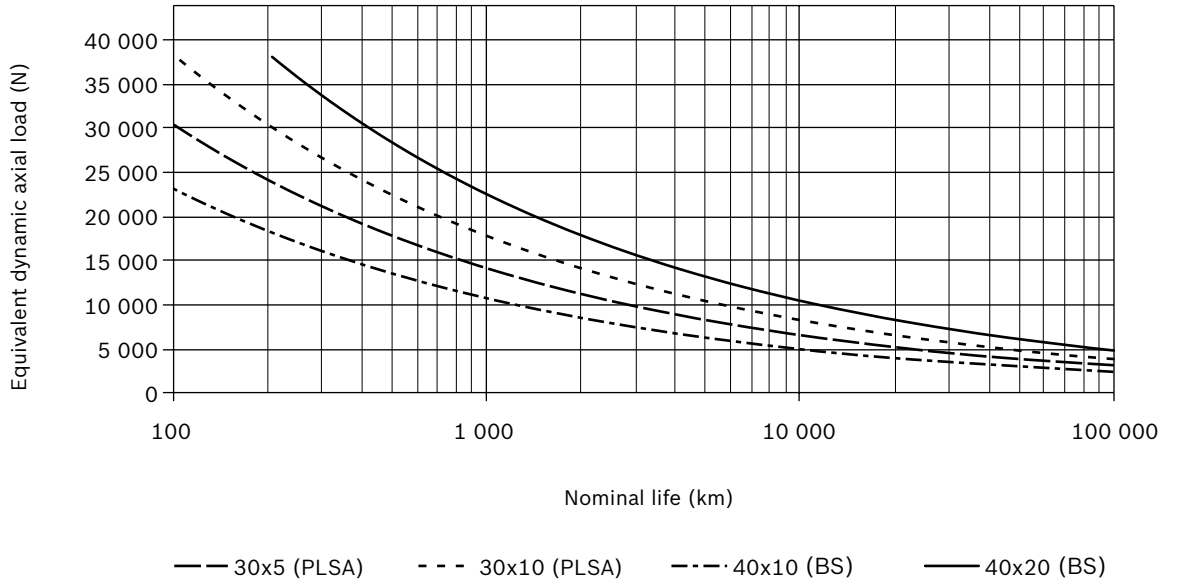

EMC-125-HD

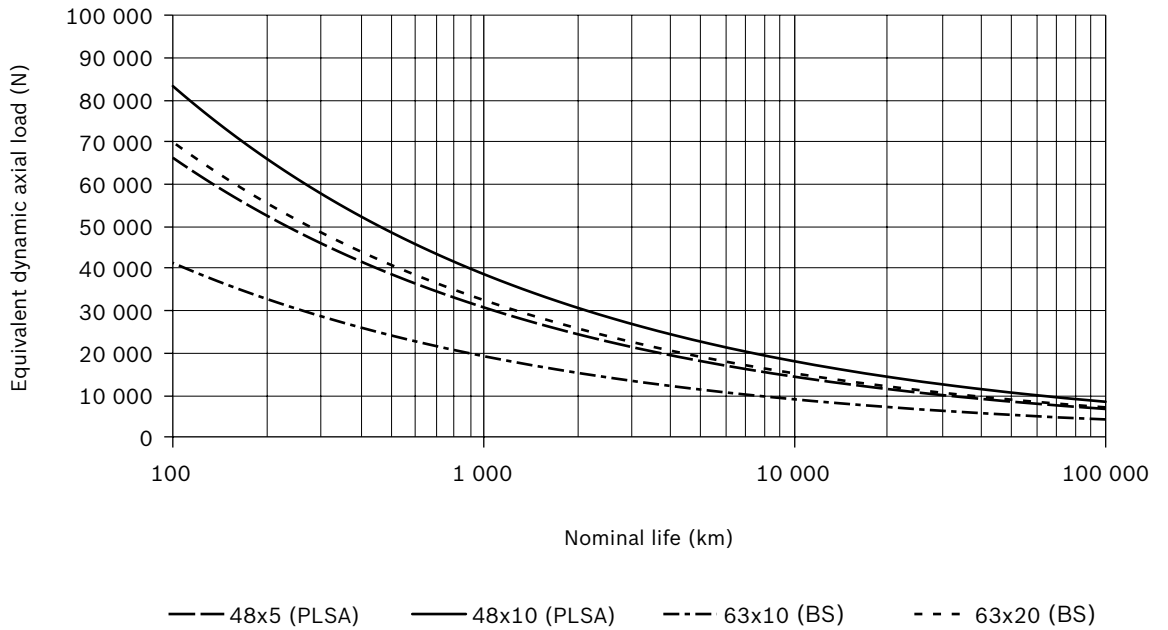

The stated values apply on compliance with the specified relubrication intervals(see the “Service and Information” section).

For calculation of the equivalent dynamic axial load F_m see the “Calculation Principles” section.

Technical Data

Drive data

Size	PLSA		BS		F_{\max} (N)	M_p (Nm)	v_{\max} (m/s)	n_p (min ⁻¹)	a_{\max} (m/s ²)	M_{Rs} (Nm)
	$d_0 \times P$ (mm)		$d_0 \times P$ (mm)							
EMC-085-HD	30x5		–		44 000	44	0.42	5040	30	6
	30x10		–		44 000	88	0.83	4980	30	6
	–		40x10		44 000	78	0.63	3780	8	5
	–		40x20		38 000	134	1.00	3000	22	5
EMC-125-HD	48x5		–		95 000	94	0.26	3120	30	12
	48x10		–		110 000	219	0.52	3120	30	12
	–		63x10		88 000	156	0.40	2400	8	10
	–		63x20		85 000 ¹⁾	301	0.80	2400	13	10

¹ When using timing belt side drives only possible up to 62 000 N

Size	PLSA		BS		$k_{J \text{ fix}}$	$k_{J \text{ var}}$	$k_{J \text{ m}}$	Backlash of screw drive (μm)	Max. perm. piston rod twist angle ¹⁾ ($^\circ$)	Perm. transmitted power ²⁾ (W)	η
	$d_0 \times P$ (mm)		$d_0 \times P$ (mm)								
EMC-085-HD	30x5		–		206	0.628	0.633	30	± 1.5	430	0.8
	30x10		–		216	0.643	2.533	30	± 1.5	430	0.8
	–		40x10		456	1.383	2.533	0	± 1.5	1 100	0.9
	–		40x20		527	1.463	10.132	0	± 1.5	2 000	0.9
EMC-125-HD	48x5		–		2046	4.104	0.633	30	± 1.5	460	0.8
	48x10		–		2065	4.125	2.533	30	± 1.5	540	0.8
	–		63x10		4459	9.645	2.533	0	± 1.5	1 100	0.9
	–		63x20		4704	9.645	10.132	0	± 1.5	2 000	0.9

¹ For version with anti-twist feature

² Calculated for 25 °C ambient temperature

a_{\max} = maximum permissible acceleration
 d_0 = diameter of screw drive
 F_{\max} = maximum permissible axial force
 $k_{J \text{ fix}}$ = constant for fixed-length portion of mass moment of inertia
 $k_{J \text{ var}}$ = constant for length-variable portion of mass moment of inertia
 $k_{J \text{ m}}$ = constant for mass-specific portion of mass moment of inertia
 i = gear ratio

m_c = mass of motor mount and coupling including gear unit
 M_p = maximum permissible drive torque
 M_{Rs} = frictional torque of EMC-HD
 n_p = maximum permissible rotary speed of EMC-HD
 P = screw drive lead
 v_{\max} = maximum permissible linear speed
 η = mechanical efficiency

Drive data for motor attachment via motor mount and coupling

EMC-HD	d _{0xP} (mm)	Attachment for motor (optionally with gear unit)	i	Motor mount and coupling incl. gear unit										
				F _{max} (N)	M _p ¹⁾ (Nm)	v _{max} (m/s)	n _p ²⁾ (min ⁻¹)	η	M _{RS} (Nm)	k _{J fix}	k _{J var}	k _{J m}	m _c (kg)	a _{max} (m/s ²)
085	30x5	MSK 071	1	44 000	44.0	0.42	5 040	0.80	6.00	1 106.0	0.628	0.633	5.0	30
		MSK 100/101	1	44 000	44.0	0.42	5 040	0.80	6.00	1 106.0	0.628	0.633	6.6	30
		MSK 071/101 with gear unit	3	44 000	15.4	0.13	4 500	0.76	5.50	1 232.9	0.070	0.070	14.0	30
		MSK 071 with gear unit	5	44 000	9.3	0.08	4 500	0.76	3.60	236.3	0.025	0.025	14.0	30
	30x10	MSK 071	1	44 000	88.0	0.83	4 980	0.80	6.00	1 116.0	0.643	2.533	5.0	30
		MSK 100/101	1	44 000	88.0	0.83	4 980	0.80	6.00	1 116.0	0.643	2.533	6.6	30
		MSK 071/101 with gear unit	3	44 000	30.9	0.25	4 500	0.76	5.50	1234.0	0.071	0.281	14.0	30
		MSK 071 with gear unit	5	44 000	18.5	0.15	4 500	0.76	3.60	236.7	0.026	0.101	14.0	30
	40x10	MSK 071	1	44 000	78.0	0.63	3 780	0.90	5.00	1 356.0	1.383	2.533	5.0	8
		MSK 100/101	1	44 000	78.0	0.63	3 780	0.90	5.00	1 356.0	1.383	2.533	6.6	8
		MSK 071/101 with gear unit	3	44 000	27.4	0.25	4 500	0.86	5.17	1 260.7	0.154	0.281	14.0	8
		MSK 071 with gear unit	5	44 000	16.4	0.15	4 500	0.86	3.40	246.3	0.055	0.101	14.0	8
	40x20	MSK 071	1	38 000	134.0	1.00	3 000	0.90	5.00	1427.0	1.463	10.132	5.0	22
		MSK 100/101	1	38 000	134.0	1.00	3 000	0.90	5.00	1427.0	1.463	10.132	6.6	22
		MSK 071/101 with gear unit	3	38 000	47.0	0.50	4 500	0.86	5.17	1 268.6	0.163	1.126	14.0	22
		MSK 071 with gear unit	5	38 000	28.2	0.30	4 500	0.86	3.40	249.1	0.059	0.405	14.0	22
125	48x5	MSK 100	1	95 000	94.0	0.26	3 120	0.80	12.00	4 136.0	4.104	0.633	6.8	30
		MSK 101	1	95 000	94.0	0.26	3 120	0.80	12.00	4 136.0	4.104	0.633	6.9	30
		MSK 100 with gear unit	3	95 000	33.0	0.13	4 500	0.76	7.50	1 569.6	0.456	0.070	14.2	30
		MSK 101 with gear unit	3	95 000	33.0	0.11	4 000	0.76	11.60	1 949.6	0.456	0.070	23.3	30
		MSK 071 with gear unit	5	95 000	19.8	0.08	4 500	0.76	4.80	357.5	0.164	0.025	14.2	30
	48x10	MSK 100	1	110 000	219.0	0.52	3 120	0.80	12.00	4 155.0	4.125	2.533	6.8	30
		MSK 101	1	110 000	219.0	0.52	3 120	0.80	12.00	4 155.0	4.125	2.533	6.9	30
		MSK 100 with gear unit	3	110 000	76.8	0.25	4 500	0.76	7.50	1 571.7	0.458	0.281	14.2	30
		MSK 101 with gear unit	3	110 000	76.8	0.22	4 000	0.76	11.60	1 951.7	0.458	0.281	23.3	30
		MSK 071 with gear unit	5	110 000	46.1	0.15	4 500	0.76	4.80	358.2	0.165	0.101	14.2	30
	63x10	MSK 100	1	88 000	156.0	0.40	2 400	0.90	10.00	6 549.0	9.645	2.533	6.8	8
		MSK 101	1	88 000	156.0	0.40	2 400	0.90	10.00	6 549.0	9.645	2.533	6.9	8
		MSK 100 with gear unit	3	88 000	54.7	0.25	4 500	0.86	6.83	1 837.7	1.072	0.281	14.2	8
		MSK 101 with gear unit	3	88 000	54.7	0.22	4 000	0.86	10.93	2 217.7	1.072	0.281	23.3	8
		MSK 071 with gear unit	5	88 000	32.8	0.15	4 500	0.86	4.40	453.9	0.386	0.101	14.2	8
	63x20	MSK 100	1	85 000	301.0	0.80	2 400	0.90	10.00	6 794.0	9.645	10.132	6.8	13
		MSK 101	1	85 000	301.0	0.80	2 400	0.90	10.00	6 794.0	9.645	10.132	6.9	13
		MSK 100 with gear unit	3	66 000	82.5	0.50	4 500	0.86	6.83	1 864.9	1.072	1.126	14.2	13
		MSK 101 with gear unit	3	85 000	105.6	0.44	4 000	0.86	10.93	2 244.9	1.072	1.126	23.3	13
		MSK 071 with gear unit	5	85 000	63.4	0.30	4 500	0.86	4.40	463.8	0.386	0.405	14.2	13

1 Torque may be limited by the maximum torque of the motor.

2 Rotary speed may be limited by the maximum speed of the motor.

Drive data for motor attachment via timing belt side drive

EMC-HD	d ₀ xP (mm)	Attachment for motor (optionally with gear unit)	i ¹⁾	Timing belt side drive incl. gear unit										
				F _{max} (N)	M _p ²⁾ (Nm)	v _{max} (m/s)	n _p ³⁾ (min ⁻¹)	η	M _{Rs} (Nm)	k _{J fix}	k _{J var}	k _{J m}	m _{sd} (kg)	a _{max} (m/s ²)
085	30x5	MSK 071/100/101	1.5	44 000	30.2	0.42	7 560	0.78	8.30	3621.6	0.2791	0.281	16.0	30
		MSK 071 with gear unit	4.5	44 000	10.6	0.08	4 500	0.74	6.27	731.4	0.0310	0.031	25.0	30
		MSK 071 with gear unit	7.5	44 000	6.4	0.05	4 500	0.74	4.06	336.9	0.0112	0.011	25.0	30
	30x10	MSK 071/100/101	1.5	44 000	60.5	0.83	7 470	0.78	8.30	3 626.0	0.2858	1.126	16.0	30
		MSK 071 with gear unit	4.5	44 000	21.2	0.17	4 500	0.74	6.27	731.9	0.0318	0.125	25.0	30
		MSK 071 with gear unit	7.5	44 000	12.7	0.10	4 500	0.74	4.06	337.1	0.0114	0.045	25.0	30
	40x10	MSK 071/100/101	1.5	44 000	53.6	0.63	5 670	0.87	7.63	3 732.1	0.6147	1.126	16.0	8
		MSK 071 with gear unit	4.5	44 000	18.8	0.17	4 500	0.83	6.04	743.8	0.0683	0.125	25.0	8
		MSK 071 with gear unit	7.5	44 000	11.3	0.10	4 500	0.83	3.93	341.3	0.0246	0.045	25.0	8
40x20	MSK 071/100/101	1.5	38 000	92.1	1.00	4 500	0.87	7.63	3764.2	0.6502	4.503	16.0	22	
	MSK 071 with gear unit	4.5	38 000	32.3	0.33	4 500	0.83	6.04	747.3	0.0722	0.500	25.0	22	
	MSK 071 with gear unit	7.5	38 000	19.4	0.20	4 500	0.83	3.93	342.6	0.0260	0.180	25.0	22	
125	48x5	MSK 100/101	1.5	95 000	64.6	0.26	4 680	0.78	14.60	11 329.3	1.8240	0.281	27.1	30
		MSK 100/101 with gear unit	4.5	95 000	22.7	0.08	4 500	0.74	8.94	1 587.8	0.2027	0.031	36.3	30
		MSK 071 with gear unit	7.5	95 000	13.6	0.05	4 500	0.74	5.32	645.2	0.0730	0.011	36.3	30
	48x10	MSK 100/101	1.5	110 000	150.5	0.52	4 680	0.78	14.60	11 337.8	1.8333	1.126	27.1	30
		MSK 100/101 with gear unit	4.5	110 000	52.8	0.17	4 500	0.74	8.37	1 588.8	0.2037	0.125	36.3	30
		MSK 071 with gear unit	7.5	110 000	31.7	0.10	4 500	0.74	5.32	645.5	0.0733	0.045	36.3	30
	63x10	MSK 100/101	1.5	88 000	107.2	0.84	7 560	0.87	13.27	12 401.8	4.2867	1.126	27.1	8
		MSK 100/101 with gear unit	4.5	88 000	37.6	0.17	4 500	0.83	7.92	1 707.0	0.4763	0.125	36.3	8
		MSK 071 with gear unit	7.5	88 000	22.6	0.10	4 500	0.83	5.05	688.1	0.1715	0.045	36.3	8
	63x20	MSK 100/101	1.5	62 000	151.2	0.80	3 600	0.87	13.27	12 510.7	4.2867	4.503	27.1	13
		MSK 100/101 with gear unit	4.5	62 000	53.1	0.33	4 500	0.83	7.92	1 719.1	0.4763	0.500	36.3	13
		MSK 071 with gear unit	7.5	62 000	31.8	0.20	4 500	0.83	5.05	692.5	0.1715	0.180	36.3	13

1 Gear ratio of timing belt side drive and gear unit.

2 Torque may be limited by the maximum torque of the motor.

3 Rotary speed may be limited by the maximum speed of the motor.

a_{max} = maximum permissible acceleration

d₀ = diameter of screw drive

F_{max} = maximum permissible axial force

k_{J fix} = constant for fixed-length portion of mass moment of inertia

k_{J var} = constant for length-variable portion of mass moment of inertia

k_{J m} = constant for mass-specific portion of mass moment of inertia

i = gear ratio

M_p = maximum permissible drive torque

M_{Rs} = frictional torque of EMC-HD

m_{sd} = mass of timing belt side drive including gear unit

n_p = maximum permissible rotary speed of EMC-HD

P = screw drive lead

v_{max} = maximum permissible linear speed

η = mechanical efficiency

Calculation Principles

Drive train

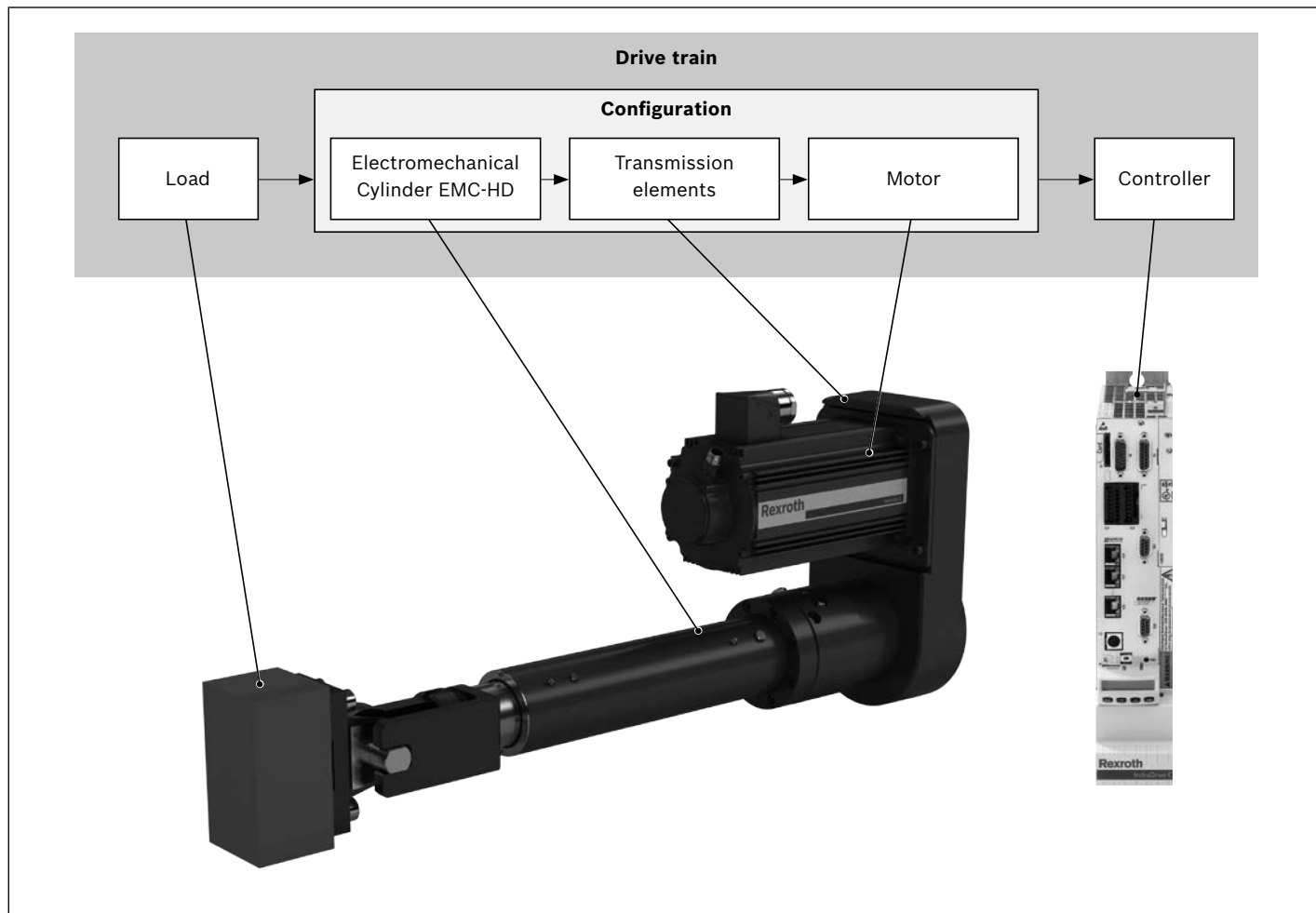

The correct dimensioning and assessment of an application requires structured consideration of the drive train as a whole. The basic element of the drive train is the configuration – comprising the Electromechanical Cylinder EMC-HD, the transmission element (coupling or timing belt side drive) and the motor which can be ordered in that constellation as per the catalog.

Maximum permissible loads

When selecting of Electromechanical Cylinders EMC-HD, maximum limits for permissible loads and forces must be taken into account. These limits can be found in the “Product Description and Technical Data” section.

The values given there are system-related. In other words, the upper limits are determined not only by the load ratings of the bearing points but also include structural design and material-related considerations.

Mechanical calculation

Useful power

To take into account the power loss in the EMC-HD, a permissible useful power is stated for each cylinder-screw drive combination, see “Technical Data”. This value applies at an ambient temperature of 25 °C and even distribution of the load over the stroke length. For applications in which the cylinder is permanently loaded over a small section of the total stroke length, please contact Bosch Rexroth.

Phases without load must be taken into account when calculating of the sum of the discrete time steps.

$$P_{app} = \frac{1}{t_{tot}} \cdot (|F_1| \cdot |v_1| \cdot t_1 + |F_2| \cdot |v_2| \cdot t_2 \dots |F_n| \cdot |v_n| \cdot t_n)$$

Service life of Electromechanical Cylinder EMC-HD

Where the operating conditions vary (fluctuating linear speed and load), the service life must be calculated using the averages values for F_m and v_m .

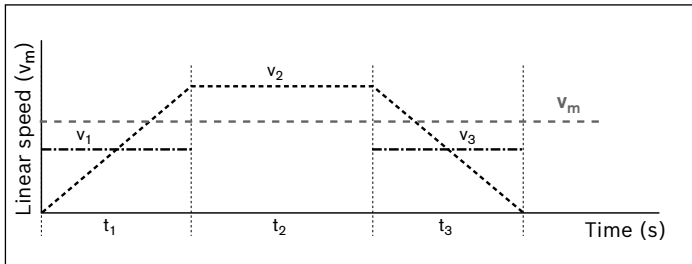

When the linear speed varies, the average speed v_m is calculated as follows:

$$v_m = \frac{1}{t_{tot}} \cdot (|v_1| \cdot t_1 + |v_2| \cdot t_2 + \dots + |v_n| \cdot t_n)$$

$$t_{tot} = t_1 + t_2 + \dots + t_n$$

When the load and rotary speed vary, the average load F_m is calculated as follows:

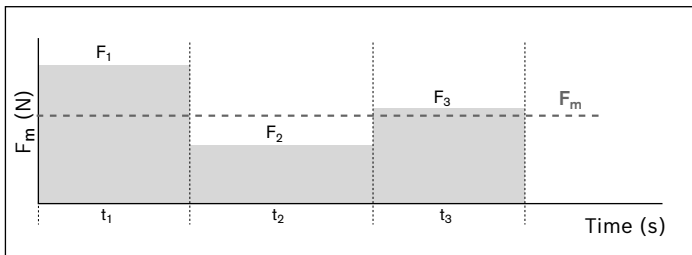

$$F_m = \sqrt[3]{|F_1|^3 \cdot \frac{|v_1|}{v_m} \cdot \frac{t_1}{t_{tot}} + |F_2|^3 \cdot \frac{|v_2|}{v_m} \cdot \frac{t_2}{t_{tot}} + \dots + |F_n|^3 \cdot \frac{|v_n|}{v_m} \cdot \frac{t_n}{t_{tot}}}$$

Nominal life

- in revolutions L_{10}

$$L_{10} = \left(\frac{C}{F_m} \right)^3 \cdot 10^6$$

- in hours L_{10h}

$$L_{10h} = \frac{L_{10}}{n_m \cdot 60}$$

Drive torque M_p :

$$M_p = \frac{F \cdot P}{2000 \cdot \pi \cdot \eta}$$

- C = dynamic load capacity
- F = load
- F_1, F_2, \dots, F_n = axial load in phase 1 ... n
- F_m = equivalent dynamic axial load
- L_{10} = nominal life in revolutions
- L_{10h} = nominal life in hours
- M_p = drive torque

- (N) P = screw drive lead
- (N) P_{app} = useful power in the application (W)
- (N) t_1, t_2, \dots, t_n = discrete time step for phases 1 ... n (s)
- (N) t_{tot} = sum of discrete time step t_1, t_2, \dots, t_n (s)
- (-) v_1, v_2, \dots, v_n = linear speed in phase 1 ... n (m/s)
- (h) v_m = average linear speed (m/s)
- (Nm) η = mechanical efficiency

Sizing the Drive

Principles

When calculating the required size of drive, the drive train can be subdivided into the **mechanical system** and the **drive** itself.

The **mechanical system** includes the physical components – Electromechanical Cylinder EMC-HD (including gear unit transmission element) – and the load to be carried.

The electric **drive** is a motor/controller combination with the appropriate performance data.

The electric drive is sized or dimensioned using the motor shaft as the reference point.

When sizing the drive, limit values must be taken into account as well as basic values. The limit (i.e. maximum) values must not be exceeded, in order to avoid damaging the mechanical components.

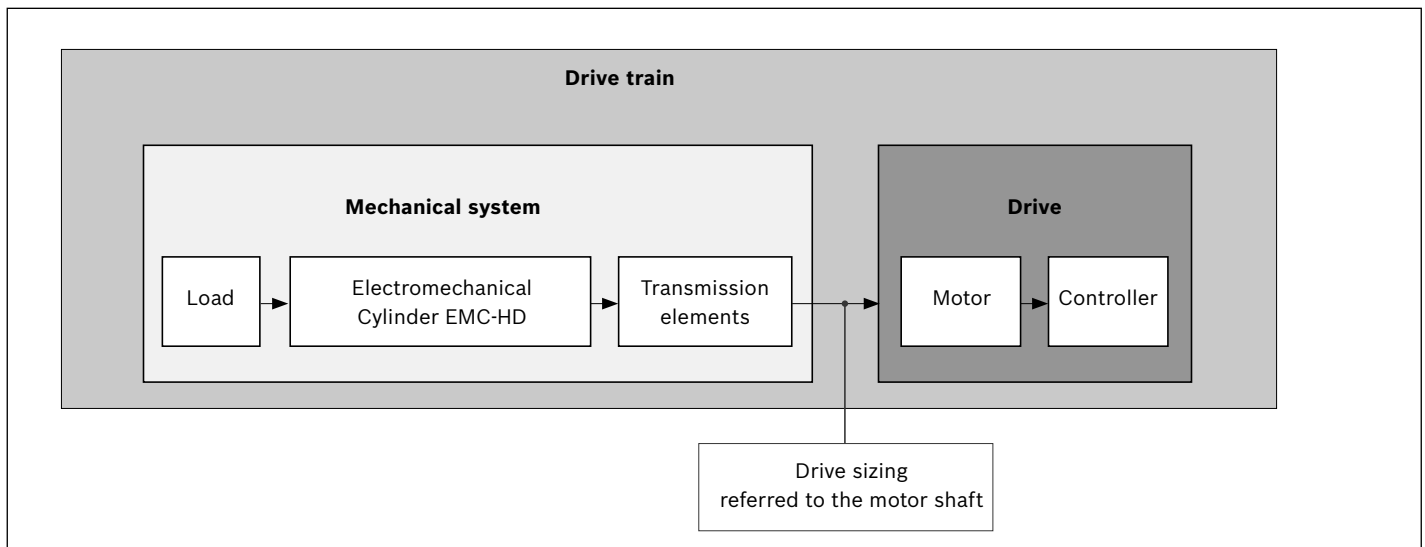

Technical data and symbols for the mechanical system

The technical data for the Electromechanical Cylinder EMC-HD already include the relevant gear unit data and the gear ratio. This means that the relevant maximum permissible values for drive torque and linear speed as well as the basic values for frictional torque and mass moment of inertia referred to the motor shaft are reduced and can be taken directly from the tables (see “Drive data”).

The following technical data with the associated symbols are used when considering the basic mechanical system requirements in the design calculations for sizing the drive. The data listed in the table below can be found in the “Technical Data” section or they are determined using the formulas described on the following pages.

	Mechanical system	
	Load	EMC-HD (incl. gear unit as transmission element)
Weight moment (Nm)	$M_g^{4)}$	–
Equivalent dynamic torque (Nm)	$M_m^{1)}$	–
Frictional torque (Nm)	–	$M_{Rs}^{3)}$
Mass moment of inertia (kgm ²)	$J_t^{1)}$	$J_s^{2)}$
Max. permissible linear speed (m/s)	–	$v_{max}^{3)}$
Max. permissible rotary speed (min ⁻¹)		$n_p^{3)}$
Max. permissible drive torque (Nm)	–	$M_p^{4)}$

- 1) Determine the value using the appropriate formula
- 2) Length-dependent value, determined using the appropriate formula
- 3) Value as per table
- 4) For vertical mounting orientation: determine the value using the appropriate formula

Drive sizing referred to the motor shaft

For drive sizing, all the relevant design calculation values for the mechanical components contained in the drive train must be determined as they relate to – and be expressed in terms of or reduced to – the motor shaft. In other words, for a combination of mechanical components within the drive train, this will result in one value for each of the following:

- Frictional torque M_R
- Mass moment of inertia J_{ex}
- Max. permissible linear speed v_{mech} (max. permissible rotary speed n_{mech})
- Max. permissible drive torque M_{mech}

Determination of the values for individual mechanical components in the drive train referred to the motor shaft

Frictional torque M_R

The value for the frictional torque of the EMC-HD already includes the friction for an appropriately configured gear reducer and has been reduced referred to the motor shaft.

For motor attachment via gear reducer

$$M_R = M_{Rs}$$

Mass moment of inertia J_{ex}

The constants used in the formulas $k_{J\ fix}$, $k_{J\ var}$ and $k_{J\ m}$ already include the mass moment of inertia and gear ratios of the related transmission elements used and can therefore be taken from the “Drive data” table.

$$J_{ex} = J_s + J_t$$

Determination of the mass moment of inertia of the EMC-HD components (including transmission elements, if used)

$$J_s = (k_{J\ fix} + k_{J\ var} \cdot s_{max}) \cdot 10^{-6}$$

Determination of the translatory mass moment of inertia of the external load (reduced to motor shaft)

$$J_t = m_{ex} \cdot k_{J\ m} \cdot s_{max} \cdot 10^{-6}$$

Maximum permissible linear speed and maximum permissible rotary speed

The value for the maximum permissible linear speed of the EMC-HD already includes the permissible rotary speed for any incorporated transmission elements.

Maximum permissible linear speed v_{mech}

$$v_{mech} = v_{max}$$

Maximum permissible rotary speed n_{mech}

$$n_{mech} = n_p$$

When considering the complete drive train (mechanical system + motor/controller) the rotary speed of the motor can lie below the maximum value for the mechanical system (M_{mech}) and thus limit the maximum permissible rotary speed of the overall drive train.

J_{ex}	=	mass moment of inertia of mechanical system	(kgm ²)	s_{max}	=	maximum travel	(mm)
J_s	=	mass moment of inertia of the linear motion system	(kgm ²)	m_{ex}	=	moved external load	(kg)
J_t	=	translatory mass moment of inertia of external load referred to the linear system drive journal	(kgm ²)	M_R	=	frictional torque at motor journal	(Nm)
$k_{J\ fix}$	=	constant for fixed-length portion of mass moment of inertia	(–)	M_{Rs}	=	frictional torque of system	(Nm)
$k_{J\ m}$	=	constant for mass-specific portion of mass moment of inertia	(–)	n_{mech}	=	maximum permissible rotary speed of mechanical system	(min ⁻¹)
$k_{J\ var}$	=	constant for variable-length portion of mass moment of inertia	(–)	n_p	=	maximum permissible rotary speed of EMC-HD	(min ⁻¹)
				v_{max}	=	maximum permissible linear speed of EMC-HD	(m/s)
				v_{mech}	=	maximum permissible linear speed of mechanical system	(m/s)

Maximum permissible drive torque M_{mech}

The lowest (minimum) of all the values for permissible drive torque of all mechanical components contained in the drive train determines the maximum permissible drive torque of the mechanical system which has to be taken into consideration as the upper limit for the drive when sizing the motor. The value for the maximum permissible drive torque of the EMC-HD already includes the maximum permissible drive torque of any incorporated transmission elements.

$$M_{\text{mech}} = M_{\text{p}}$$

When considering the complete drive train (mechanical system + motor/controller) the maximum torque of the motor can lie below the maximum value for the mechanical system (M_{mech}) and thus limit the maximum permissible drive torque of the overall drive train.

If the maximum torque of the motor lies above the upper limit for the mechanical system (M_{mech}), the maximum motor torque must be limited to the permitted value for the mechanical system.

Rough guide for pre-selection of the motor

The following conditions can be used as a rough guide for pre-selecting the motor.

Condition 1:

The speed of the motor must be the same as or higher than the speed required for the mechanical system (but not exceeding the maximum permissible value).

$$n_{\text{max}} \geq n_{\text{mech}}$$

Condition 2:

Consideration of the ratio of mass moments of inertia of the mechanical system and the motor. The ratio of the moments of inertia is used as an indicator for the quality of the control of a motor/controller combination. The ratio of the mass moments of inertia serves as an indicator for the control performance of a motor-controller combination.

Mass moment of inertia ratio

$$v = \frac{J_{\text{ex}}}{J_{\text{m}} + J_{\text{br}}}$$

For pre-selection, experience has shown that the following ratios will result in high control performance.

These are not rigid limits, but values exceeding them will require closer consideration of the specific application.

Application area	V
Handling	≤ 6.0
Processing	≤ 1.5

Condition 3:

Estimation of the ratio of the static load moment to the continuous torque of the motor. The torque ratio must be less than or equal to the empirical value of 0.6. By looking at the required motor torque levels, this estimation roughly covers the dynamic characteristics which still have to be determined by plotting an exact motion profile.

Torque ratio:

$$\frac{M_{\text{stat}}}{M_0} \leq 0.6$$

Static load moment:

$$M_{\text{stat}} = M_R + M_g + M_m$$

Weight moment:

For vertical mounting orientation only!

For motor attachment via motor mount and coupling: $i = 1$

$$M_g = \frac{P \cdot (m_{\text{ex}} + m_{\text{ca}}) \cdot g}{2000 \cdot \pi \cdot i \cdot \eta}$$

Equivalent dynamic torque:

$$M_m = \frac{F_m \cdot P}{2000 \cdot \pi \cdot i \cdot \eta}$$

When considering the torque ratio, the torque demand from the axial loads in the cycle must be included in the static load moment. The equivalent dynamic torque can be calculated approximately via the average load F_m . The value to be used for mechanical efficiency will depend on the drive element, ball screw or PLSA.

In the “Configuration and Ordering” section, users can put together standard configurations including gear reducer and motor, for the various EMC-HD sizes by selecting the appropriate options. By checking the three conditions stated above, it is possible to see whether a standard motor selected in a particular configuration will generally be of a suitable size for the specific application.

Precise sizing of the drive

Pre-selecting the motor according to this rough guide is no substitute for the required precise design calculations for the drive, taking all moments/torques and speed levels into account. For precise calculation of the electric drive, including consideration of the specific motion profile, please refer to the performance data in the IndraDrive C catalog. When sizing the drive, the maximum permitted values for linear speed, drive torque and acceleration must not be exceeded, in order to avoid damaging the mechanical system!

F_m	=	equivalent dynamic axial load	(N)	M_p	=	maximum permissible drive torque of EMC-HD	(Nm)
g	=	gravitational acceleration (= 9.81)	(m/s ²)	M_0	=	continuous motor torque	(Nm)
i	=	gear ratio of timing belt side drive/gear reducer	(-)	M_R	=	frictional torque at motor journal	(Nm)
J_{br}	=	mass moment of inertia of motor brake	(kgm ²)	M_{stat}	=	static load moment	(Nm)
J_{ex}	=	mass moment of inertia of mechanical system	(kgm ²)	n_{mech}	=	maximum permissible rotary speed of mechanical system	(min ⁻¹)
J_m	=	mass moment of inertia of motor	(kgm ²)	n_{max}	=	maximum speed of motor	(min ⁻¹)
m_{ca}	=	moved mass of carriage	(kg)	P	=	screw drive lead	(mm)
m_{ex}	=	moved external load	(kg)	V	=	ratio of mass moments of inertia of drive train and motor	(-)
M_g	=	weight moment at motor journal	(Nm)	η	=	mechanical efficiency	(-)
M_{mech}	=	maximum permissible drive torque of mechanical system	(Nm)				
M_m	=	equivalent dynamic torque	(Nm)				

EMC-085-HD – Configuration and Ordering

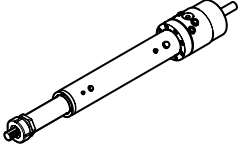
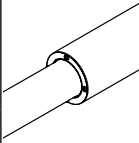
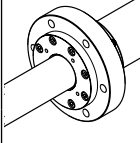
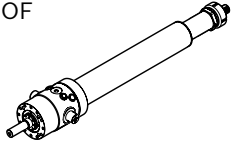
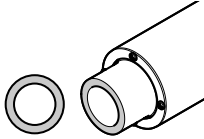
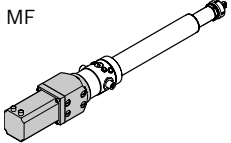
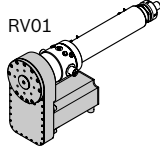
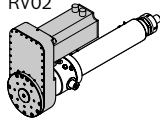
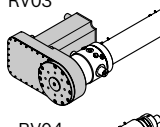
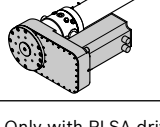
Short product name, s_{max} EMC-085-HD-1, ... mm	Guideway		Drive units				Lubrication		Version
	Without round flange	With round flange	PLSA $d_0 \times P$		Ball screw $d_0 \times P$		With initial greasing	Prelubricated with low-temperature grease	
			30 x 5	30 x 10	40 x 10	40 x 20	With initial greasing	Prelubricated with low-temperature grease	Description
Without anti-twist feature	01	02	01	02	12	13	01	02 ¹⁾	Without motor mount OF 
									With motor mount MF 
With anti-twist feature	11	12							With timing belt side drive (SD) RV01  RV02  RV03  RV04 

1) Only with PLSA drive

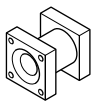
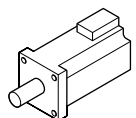
Gear ratio	Motor attachment		Motor			Switches				Surface finish		Documentation		
	 Description		 Without brake With brake			Without switch	1 reference switch	2 limit switches	2 limit switches and 1 reference switch	Standard	Black painted	Standard report	Measurement report	
	Without	00	Without	00	00									
i = 1	With motor mount	01	MSK 071D	114	115	00	01	02	03	01	13	01	02 ²⁾	03 ³⁾
		02	MSK 100B	116	117									
03	MSK 101D	118	119											
	MSK 101E	120	121											
i = 3	With motor mount and gear unit	06	MSK 071D	114	115									
		07	MSK 101D	118	119									
i = 5	With motor mount and gear unit	16	MSK 071D	114	115									
i = 1.5	Timing belt side drive	40	MSK 071D	114	115									
		41	MSK 100B	116	117									
		42	MSK 101D	118	119									
			MSK 101E	120	121									
i = 4.5	SD (i = 1.5) and gear unit (i = 3)	50	MSK 071D	114	115									
i = 7.5	SD (i = 1.5) and gear unit (i = 5)	70	MSK 071D	114	115									

2) Frictional torque measurement

3) Lead deviation

EMC-085-HD – Configuration and Ordering

Mounting elements

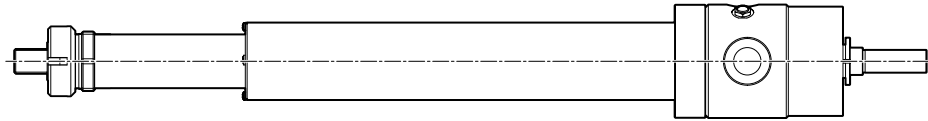

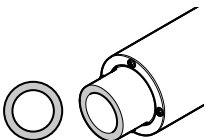
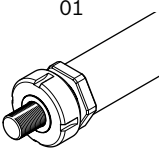
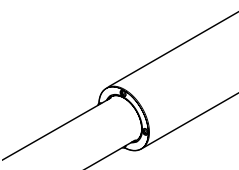
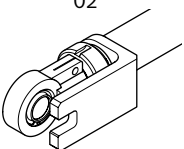
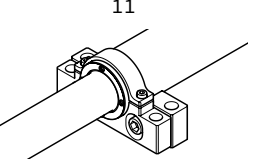
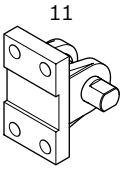
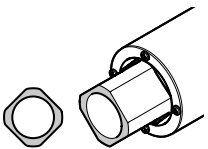
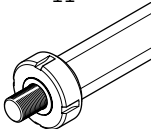
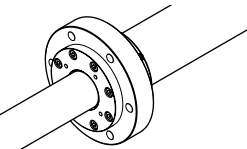
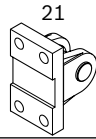
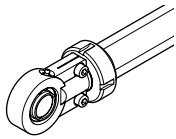
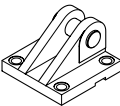
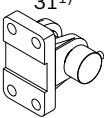
Version	Group 1	Group 2	Version	Group 3
Without anti-twist feature 	00	01 	Without round flange 	00
	00	02 		11 
	11 			
With anti-twist feature 	00	11 	With round flange 	00
	21 	12 		
	22 			
	31 ¹⁾ 			

1) With load measuring pin (see "Attachments and Accessories" section)

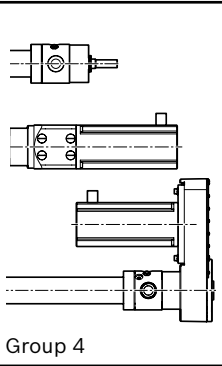
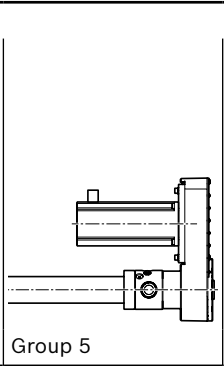
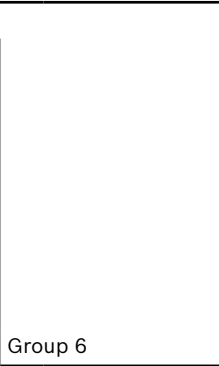
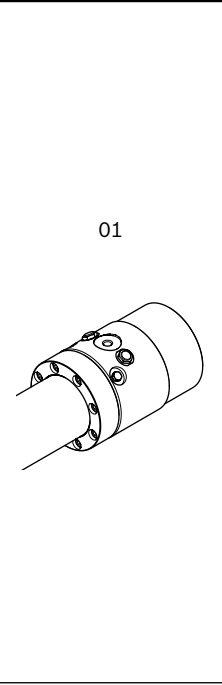
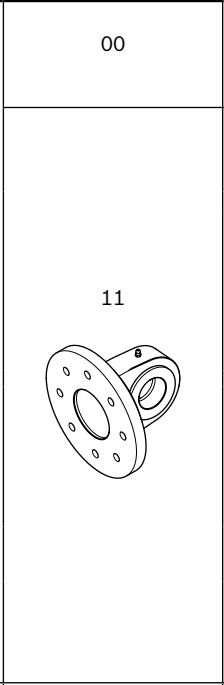
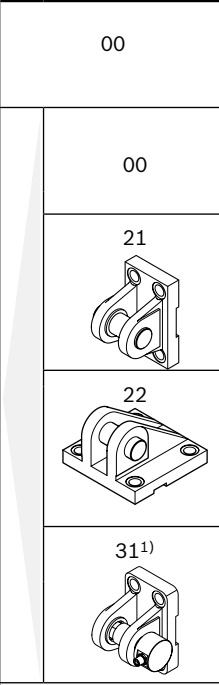
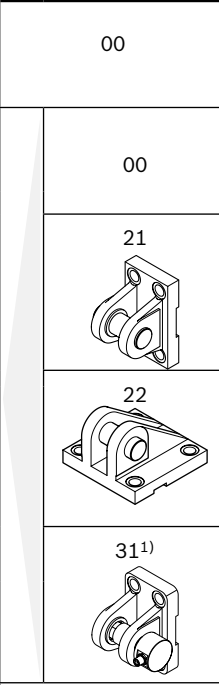
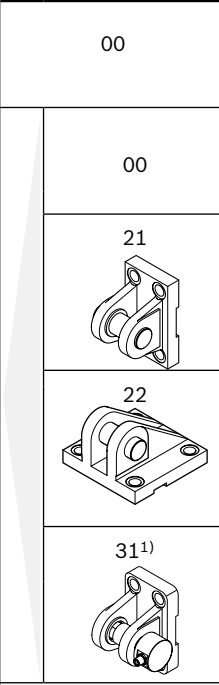
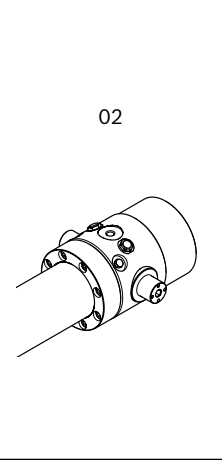
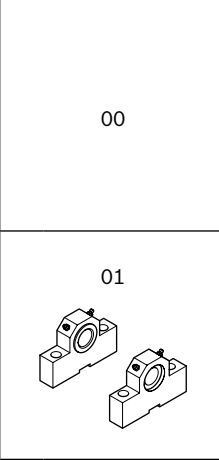
 <p>Group 4</p>	 <p>Group 5</p>	 <p>Group 6</p>
<p>01</p> 	<p>00</p> <p>11</p> 	<p>00</p> <p>00</p> <p>21</p>  <p>22</p>  <p>31¹⁾</p> 
<p>02</p> 	<p>00</p>	<p>00</p> <p>01</p> 
<p>01</p>	<p>00</p>	<p>00</p>

EMC-085-HD – Dimension Drawings

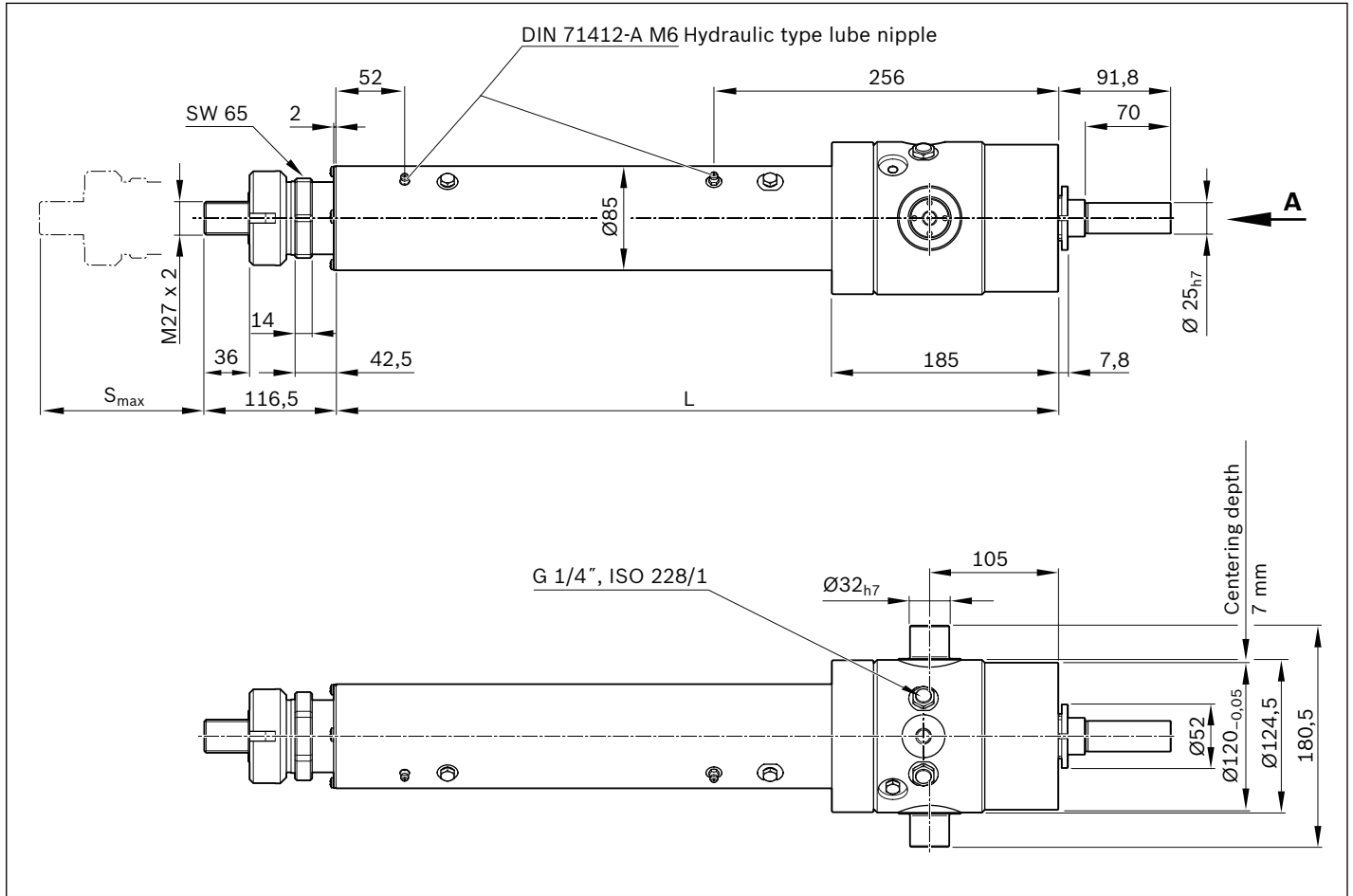

Effective stroke

For safe operation, the excess travel must be longer than the braking distance. The acceleration travel can be taken as a guideline value for the braking distance.

In most cases, this will be sufficient:

Excess travel = $2 \cdot \text{screw lead (P)}$

Example: Ball screw ($d_0 \times P$) 63x10:

Excess travel = $2 \cdot 10 \text{ mm} = 20 \text{ mm}$

Maximum travel s_{max} as per customer specification.

$$s_{\text{eff}} = s_{\text{max}} - 2 \cdot s_e$$

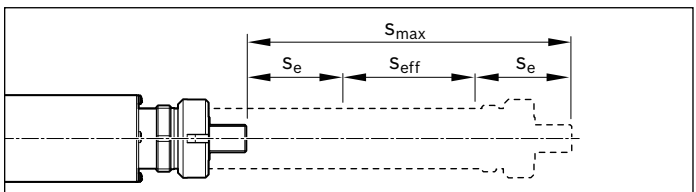

- s_e = excess travel (mm)
- s_{eff} = effective stroke (mm)
- s_{max} = maximum travel (mm)

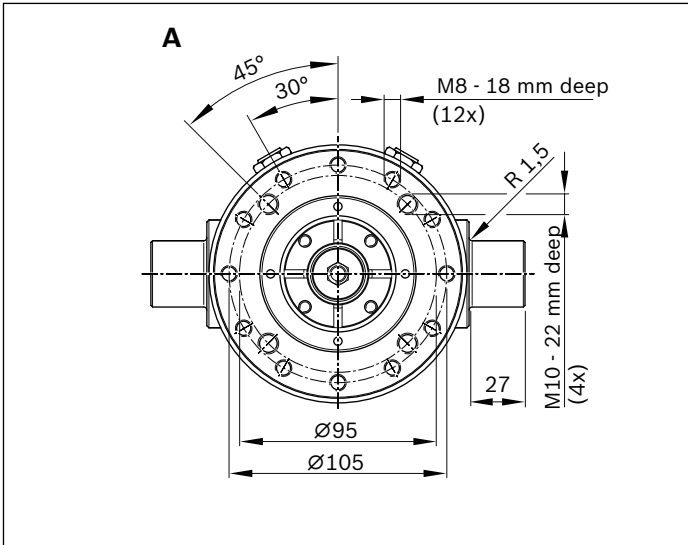

Lock nut on threaded mounting interface

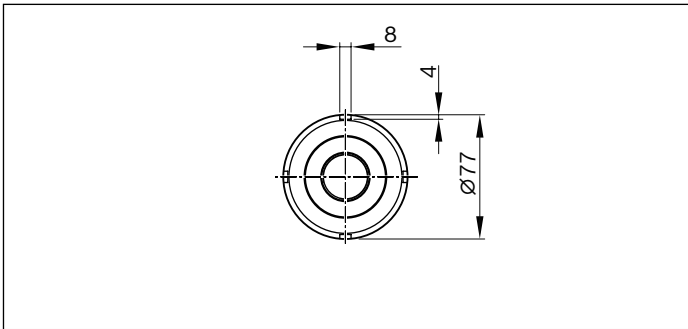

Length calculation L

	d₀xP	L_{ad} (mm)
PLSA	30x5	352
	30x10	352
BS	40x10	352
	40x20	370

$$L = s_{max} + L_{ad}$$

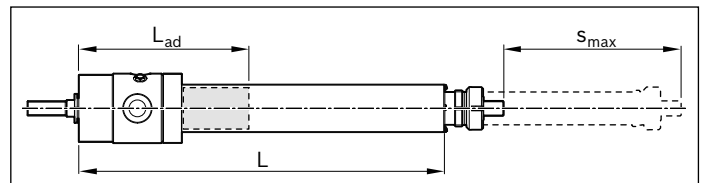

- L = overall length (without piston rod) (mm)
- L_{ad} = additional length (mm)
- s_{max} = maximum travel (mm)

EMC-085-HD – Motor Attachments

MF01

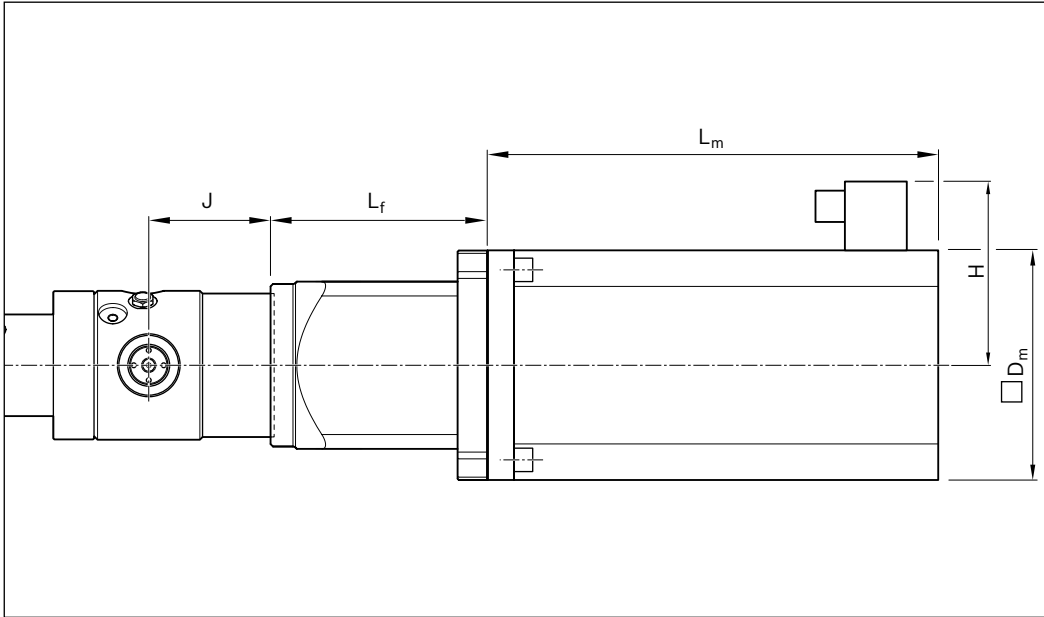

MF01 with gear unit

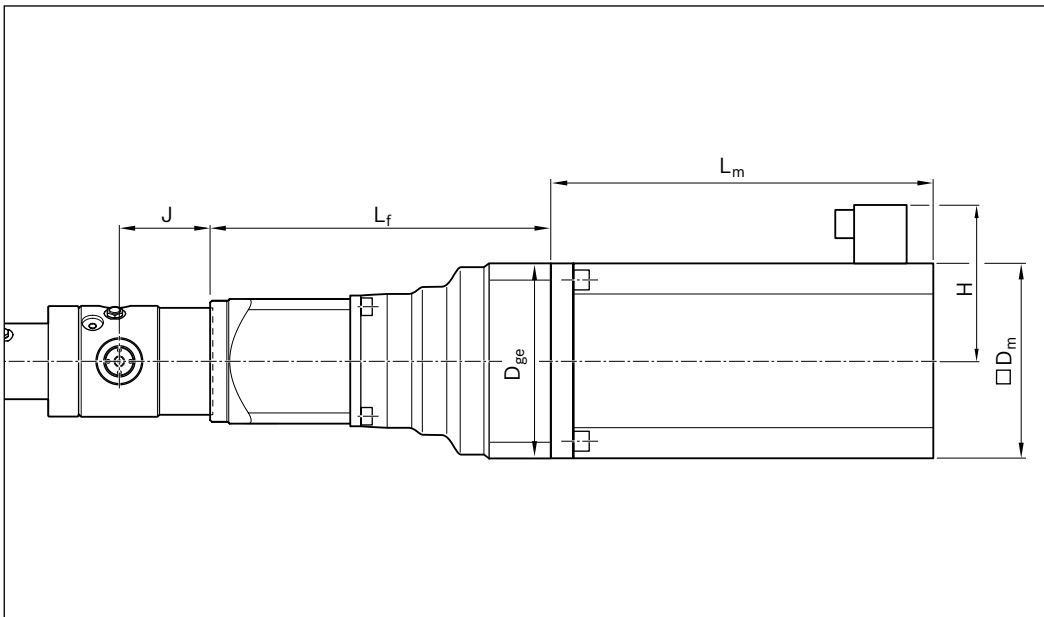

Motor	Option	i	Dimensions (mm)		D _m	D _{ge}	L _f	J	H
			With brake	Without brake					
MSK071D	01	–	347	312	140	–	153.5	105	132
	06	3	347	312	140	150	339.5	105	132
	16	5	347	312	140	150	339.5	105	132
MSK100B	02	–	368	368	192	–	178.5	105	166
MSK101D	03	–	410	410	192	–	178.5	105	166
	07	3	410	410	192	190	339.5	105	166
MSK101E	03	–	501	501	192	–	178.5	105	166

RV01, RV02, RV03, RV04

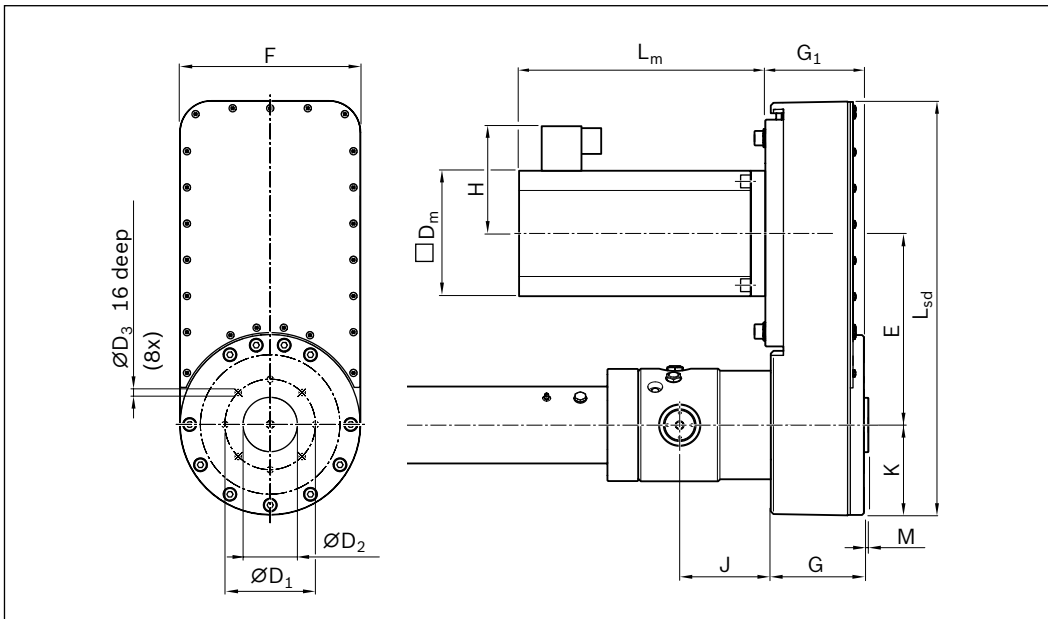

RV01, RV02, RV03, RV04 with gear unit

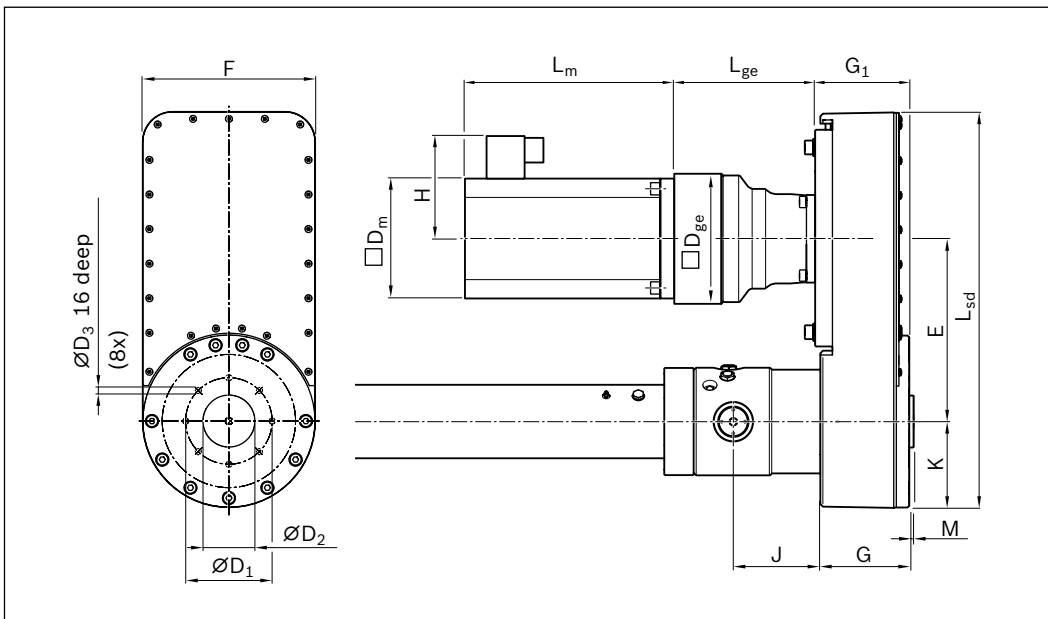

Motor	Option	i	Dimensions (mm)																
			L _{sd}	E	K	G	G ₁	J	M	With brake	Without brake	L _m	L _{ge}	D _m	D _{ge}	H	F	ØD ₁	ØD ₂ g7
MSK071D	40	1.5	458	211	100	99	99	105	5	347	312	-	140	-	132	200	100	60	M8
	50	4.5	458	211	100	99	99	105	5	347	312	156	140	150	132				
	70	7.5	458	211	100	99	99	105	5	347	312	156	140	150	132				
MSK100B	41	1.5	458	211	100	99	99	105	5	368	368	-	192	-	166	200	100	60	M8
MSK101D	42	1.5	458	211	100	99	99	105	5	410	410	-	192	-	166				
MSK101E	42	1.5	458	211	100	99	99	105	5	501	501	-	192	-	166				

EMC-125-HD – Configuration and Ordering

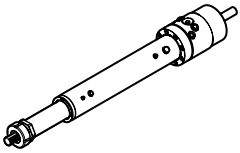
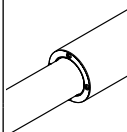
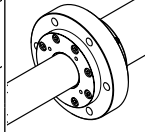
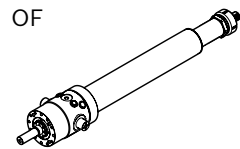
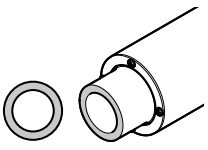
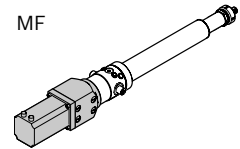
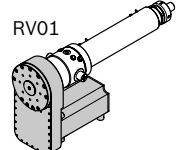
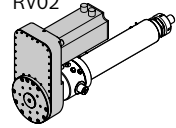
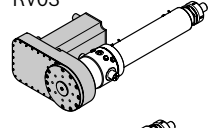
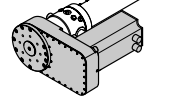
Short product name, s_{max} EMC-125-HD-1, ... mm	Guideway		Drive units				Lubrication		Version
	Without round flange	With round flange	PLSA $d_0 \times P$		Ball screw $d_0 \times P$		With initial greasing	Prelubricated with low-temperature grease	
			48 x 5	48 x 10	63 x 10	63 x 20	With initial greasing	Prelubricated with low-temperature grease	Description
Without anti-twist feature	01	02							Without motor mount OF 
									With motor mount MF 
With anti-twist feature	11	12	01	02	12	13	01	02 ¹⁾	With timing belt side drive (SD) RV01  RV02  RV03  RV04 

1) Only with PLSA drive

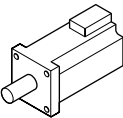
Gear ratio	Motor attachment		Motor			Switches				Surface finish		Documentation		
	 Description		 Without brake With brake			Without switch	1 reference switch	2 limit switches	2 limit switches and 1 reference switch	Standard	Black painted	Standard report	Measurement report	
	Without	00	Without	000	000	00	01	02	03	01	13	01	02 ²⁾	03 ³⁾
i = 1	With motor mount	02	MSK 100B	116	117									
		03	MSK 101D	118	119									
			MSK 101E	120	121									
i = 3	With motor mount and gear unit	06	MSK 100B	116	117									
		07	MSK 101D	118	119									
i = 5	With motor mount and gear unit	16	MSK 071D	114	115									
i = 1.5	Timing belt side drive	41	MSK 100B	116	117									
		42	MSK 101D	118	119									
			MSK 101E	120	121									
i = 4.5	SD (i = 1.5) and gear unit (i = 3)	51	MSK 100B	116	117									
		52	MSK 101D	118	119									
i = 7.5	SD (i = 1.5) and gear unit (i = 5)	70	MSK 071D	114	115									

2) Frictional torque measurement

3) Lead deviation

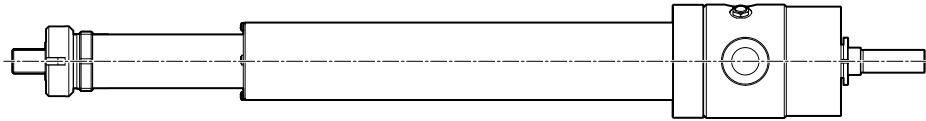

EMC-125-HD – Configuration and Ordering

Mounting elements

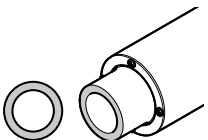
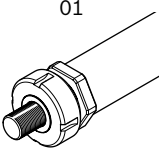
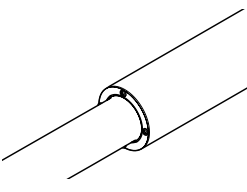
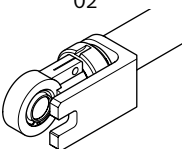
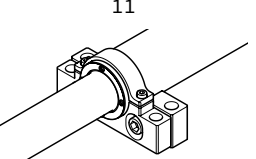
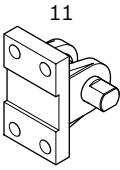
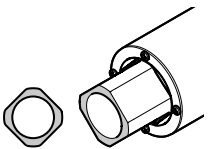
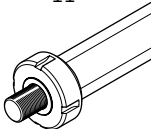
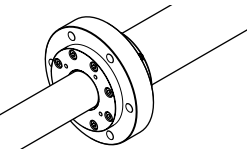
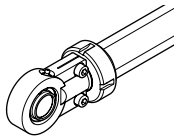
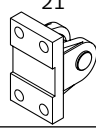
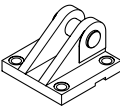
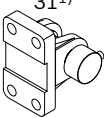

Version	Group 1	Group 2	Version	Group 3
Without anti-twist feature 	00	01 	Without round flange 	00
	00	02 		11 
	11 			
With anti-twist feature 	00	11 	With round flange 	00
	00	12 		
	21 			
	22 			
31 ¹⁾ 				

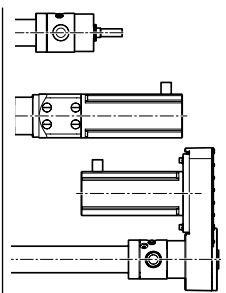
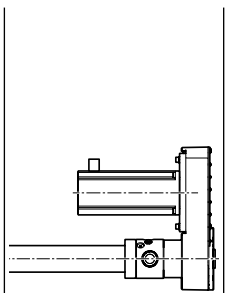
1) With load measuring pin (see "Attachments and Accessories" section)

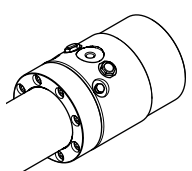
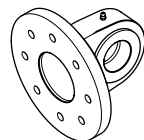
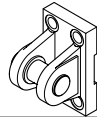
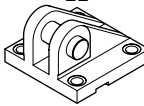
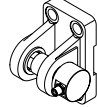
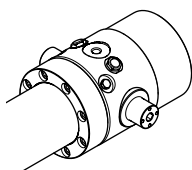
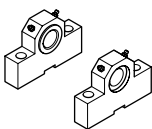
		
Group 4	Group 5	Group 6
<p data-bbox="255 798 287 829">01</p> 	<p data-bbox="478 606 510 638">00</p> <p data-bbox="478 861 510 893">11</p> 	<p data-bbox="702 606 734 638">00</p> <p data-bbox="726 734 758 766">00</p> <p data-bbox="726 808 758 840">21</p>  <p data-bbox="726 968 758 1000">22</p>  <p data-bbox="718 1117 766 1149">31¹⁾</p> 
<p data-bbox="255 1372 287 1404">02</p> 	<p data-bbox="478 1489 510 1521">00</p>	<p data-bbox="702 1372 734 1404">00</p> <p data-bbox="702 1532 734 1564">01</p> 
<p data-bbox="255 1819 287 1851">01</p>	<p data-bbox="478 1819 510 1851">00</p>	<p data-bbox="702 1819 734 1851">00</p>

EMC-125-HD – Dimension Drawings

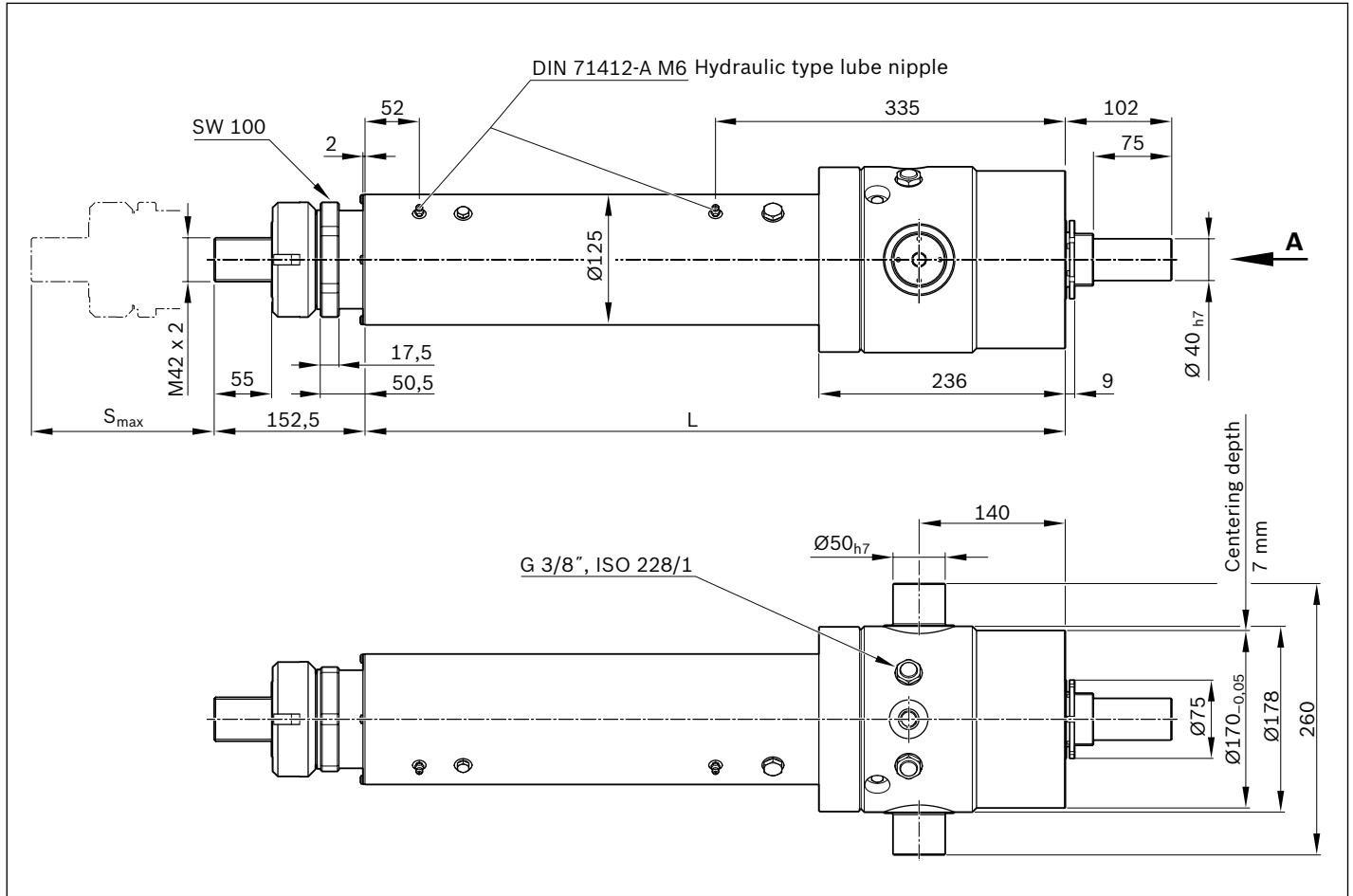

Effective stroke

For safe operation, the excess travel must be longer than the braking distance. The acceleration travel can be taken as a guideline value for the braking distance.

In most cases, this will be sufficient:

Excess travel = $2 \cdot \text{screw lead (P)}$

Example: Ball screw ($d_0 \times P$) 63x10:

Excess travel = $2 \cdot 10 \text{ mm} = 20 \text{ mm}$

Maximum travel s_{max} as per customer specification.

$$s_{\text{eff}} = s_{\text{max}} - 2 \cdot s_e$$

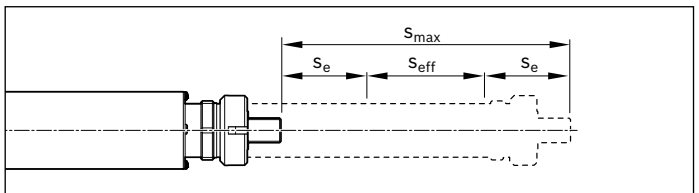

- s_e = excess travel (mm)
- s_{eff} = effective stroke (mm)
- s_{max} = maximum travel (mm)

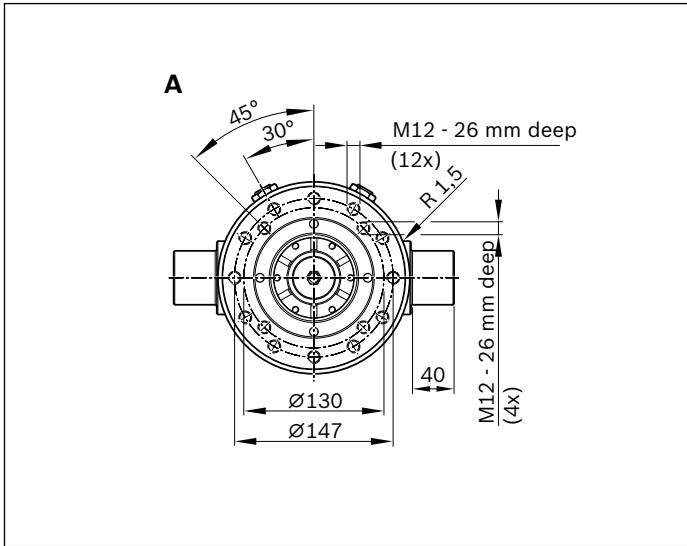

Slotted nut on threaded mounting interface

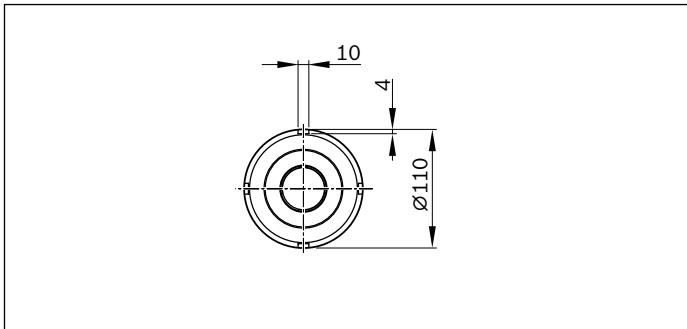

Length calculation L

	$d_0 \times P$	L_{ad} (mm)
PLSA	48x5	442
	48x10	442
BS	63x10	405
	63x20	427

$$L = s_{max} + L_{ad}$$

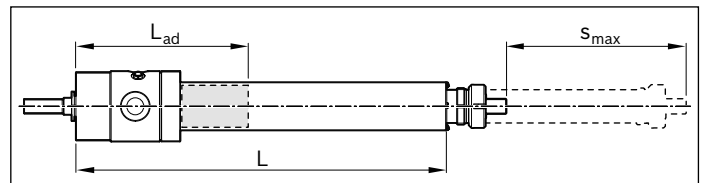

- L = overall length (without piston rod) (mm)
- L_{ad} = additional length (mm)
- s_{max} = maximum travel (mm)

EMC-125-HD – Motor Attachments

MF01

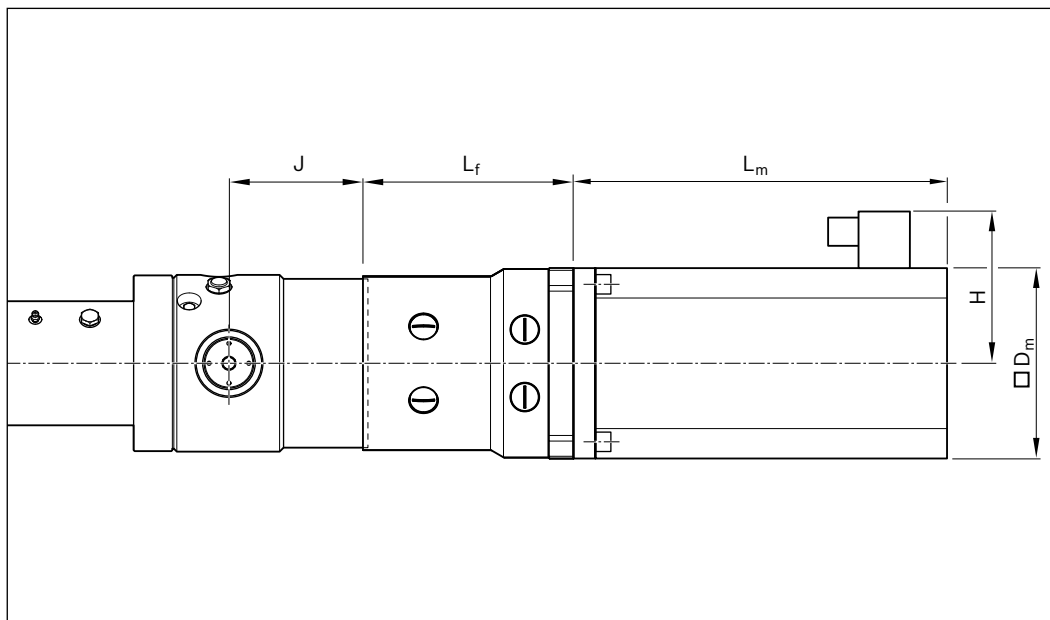

MF01 with gear unit

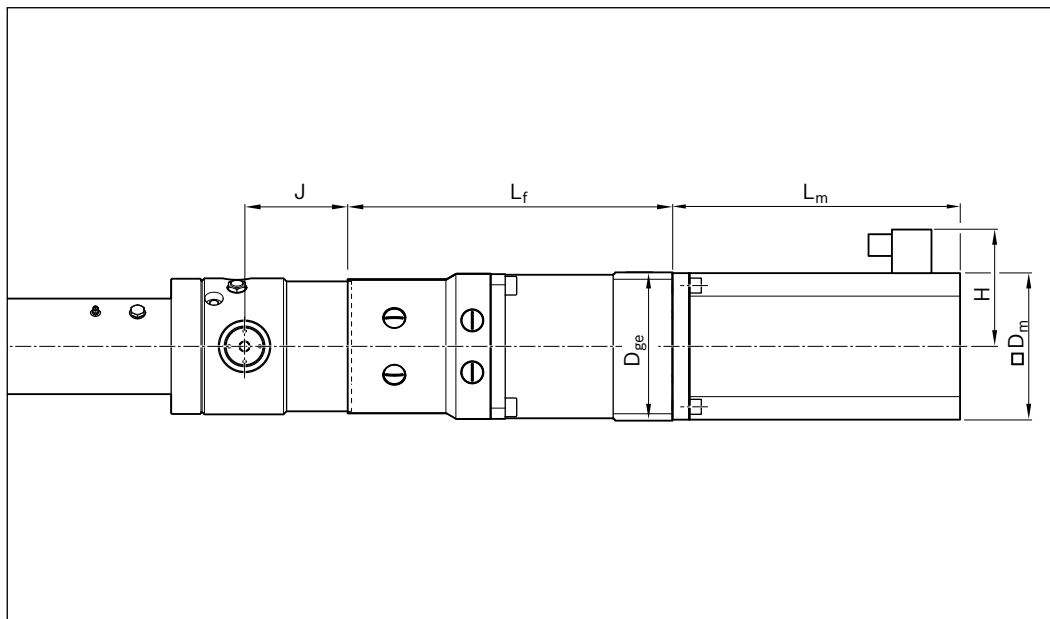

Motor	Option	i	Dimensions (mm)						
			With brake	Without brake	D_m	D_{ge}	L_f	J	H
MSK071D	16	5	347	312	140	150	388.3	140	132
MSK100B	02	-	368	368	192	-	207.0	140	166
	06	3	368	368	192	190	368.0	140	166
MSK101D	03	-	410	410	192	-	207.0	140	166
	07	3	410	410	192	190	388.3	140	166
MSK101E	03	-	410	410	192	-	207.0	140	166

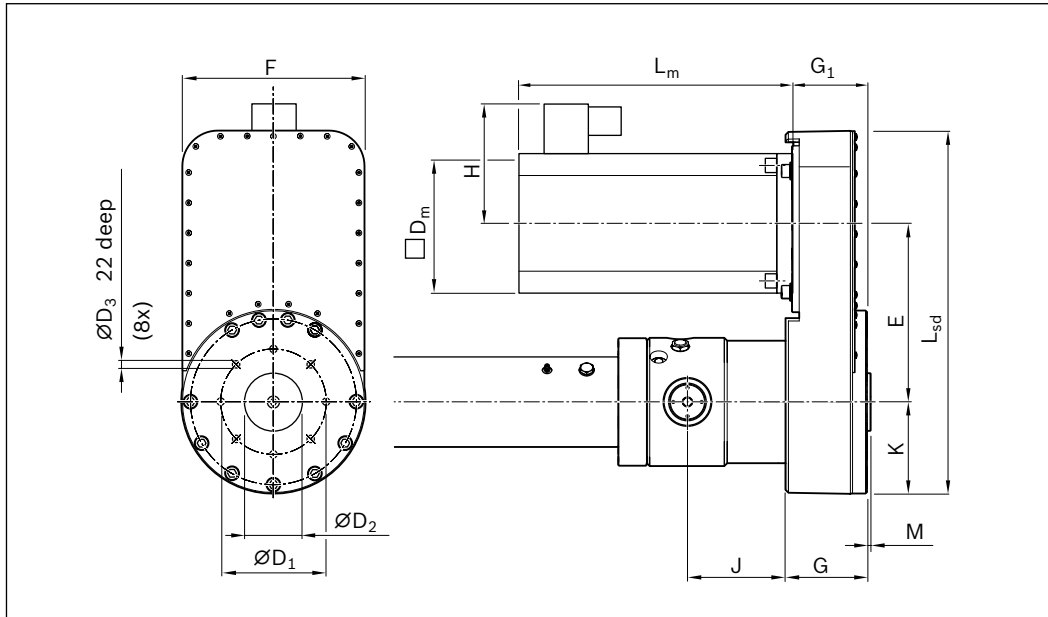
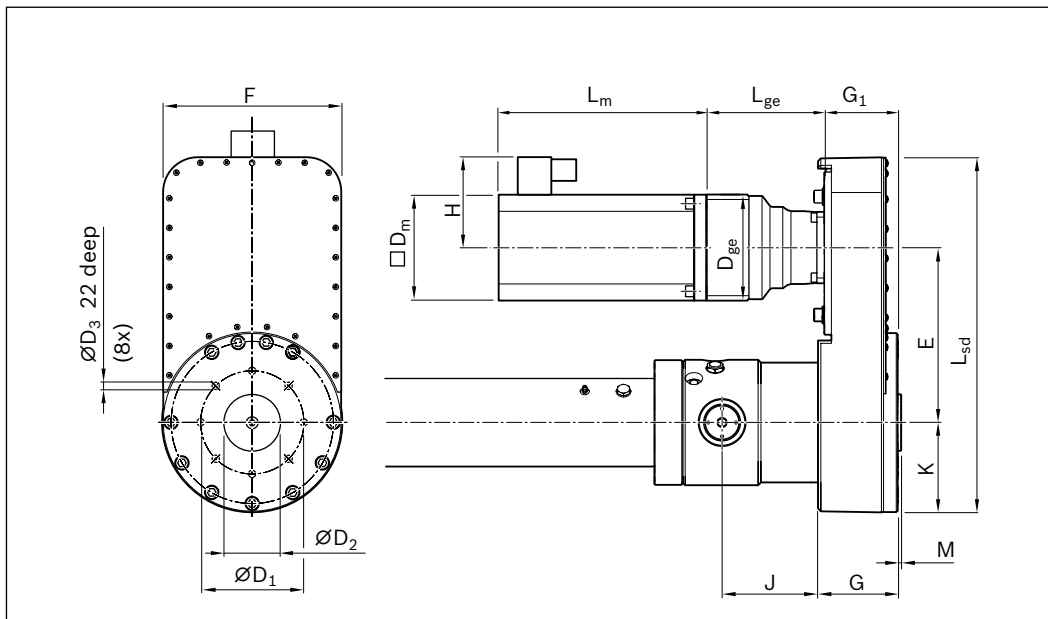
RV01, RV02, RV03, RV04

RV01, RV02, RV03, RV04 with gear unit

Motor	Option	i	Dimensions (mm)													F	$\varnothing D_1$	$\varnothing D_2$ g7	$\varnothing D_3$
			L_{sd}	E	K	G	G_1	J	M	With brake	Without brake	L_m	L_{ge}	D_m	D_{ge}				
MSK100B	41	1.5	504	248	128	109	104	140	5	368	368	-	192	-	166	255	145	80	M12
MSK101D	42	1.5	504	248	128	109	104	140	5	410	410	-	192	-	166				
MSK101E	42	1.5	504	248	128	109	104	140	5	501	501	-	192	-	166				
MSK100B	51	4.5	504	248	128	109	114	140	5	368	368	156	192	190	166				
MSK101D	52	4.5	504	248	128	109	114	140	5	410	410	156	192	190	166				
MSK071D	70	7.5	504	248	128	109	114	140	5	347	312	156	140	150	132				

Mounting Elements

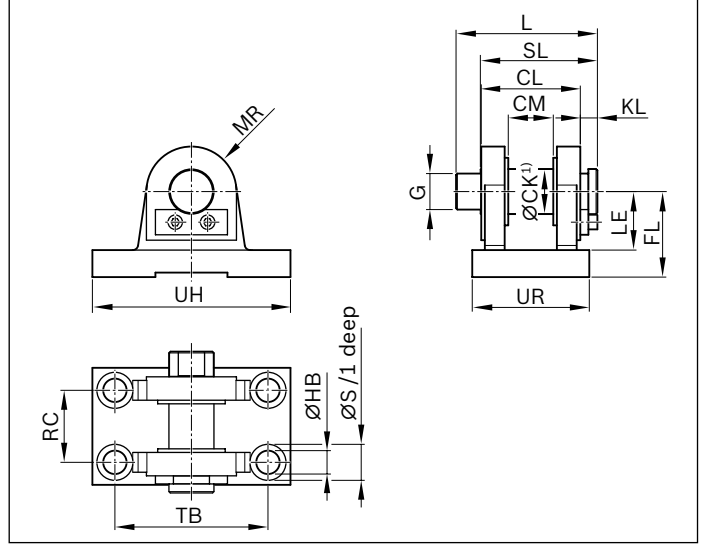
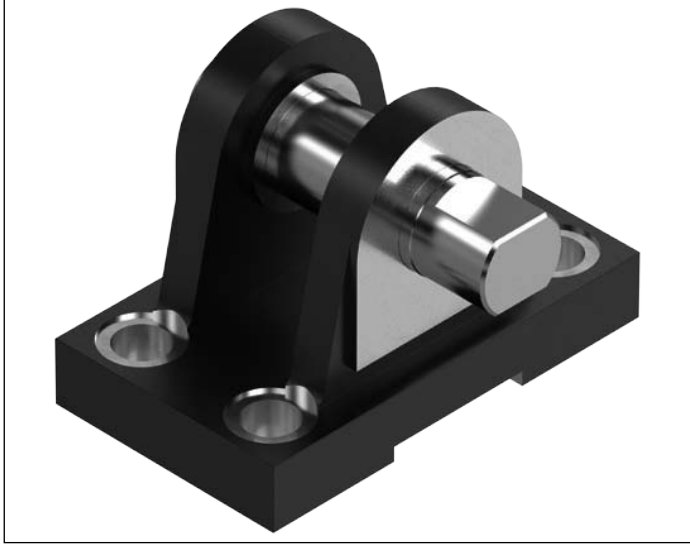
Clevis bracket CLCD (comparable with ISO 8132) for spherical rod end bearing with clevis, form A Group 1, option 11



Size	Part number	Dimensions (mm)																m (kg)
		ØCK ¹⁾ H9	CL h16	CM A12	FL js12	ØHB H13	KL	LE min.	MR max.	RC js14	ØS	SL ²⁾	L ²⁾	G ²⁾ f7	TB js14	UR max.	UH max.	
EMC-085-HD	R156330100	32	70	32	65	17.5	13	43	32	50	26	90.5	114.5	25	110	85	143	3.15
EMC-125-HD	R156350100	50	110	50	95	26.0	19	65	50	80	40	130.0	157.0	40	170	130	220	10.95

¹ Matching pivot pin Ø f7 (pin and pin locking feature are included in the scope of supply and are not ready-mounted on delivery)

² Values deviate from ISO 8132 standard

Clevis bracket CLCD ISO 8132, form A
Group 1/6, option 21

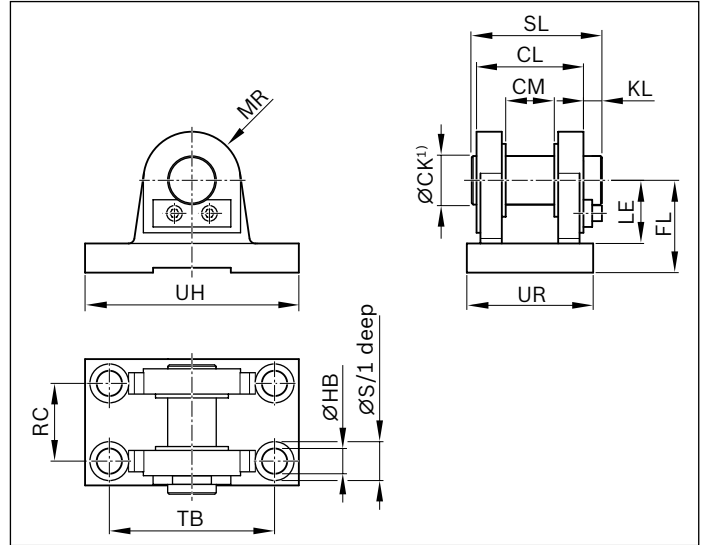
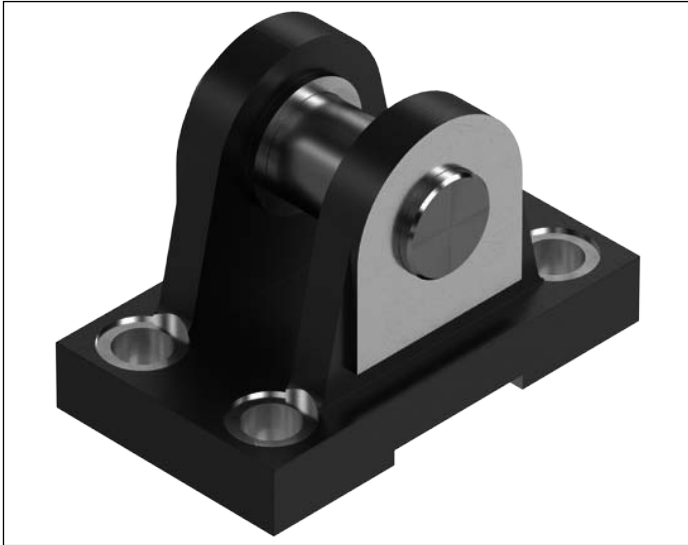

Size	Part number	Dimensions (mm)														m (kg)
		ØCK ¹⁾ H9	CL h16	CM A12	FL js12	ØHB H13	KL	LE min.	MR max.	RC js14	ØS	SL	TB js14	UR max.	UH max.	
EMC-085-HD	R156330101	32	70	32	65	17.5	13	43	32	50	26	87	110	85	143	3.0
EMC-125-HD	R156350101	50	110	50	95	26.0	19	65	50	80	40	133	170	130	220	10.6

1 Matching pivot pin Ø m6 (pin and pin locking feature are included in the scope of supply and are not ready-mounted on delivery)

Mounting Elements

Clevis bracket CLCA ISO 8132, form B

Group 1 / 6, option 22

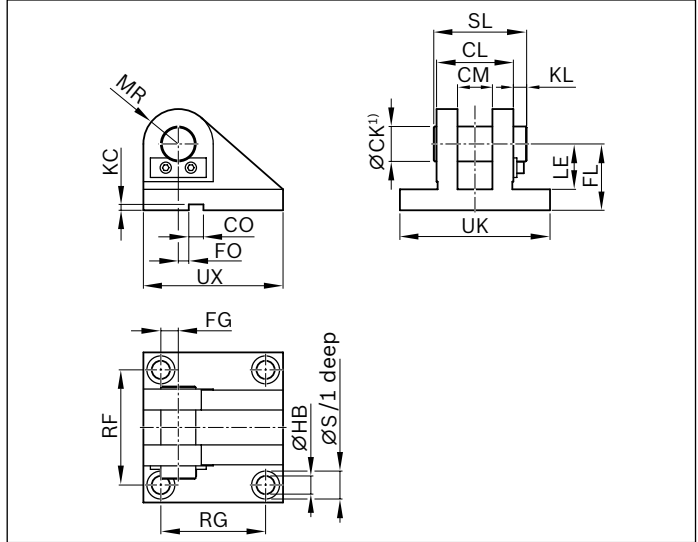
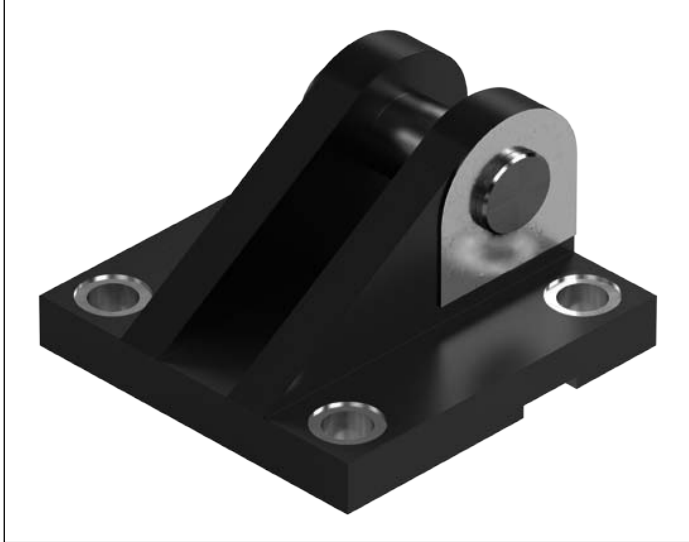

Size	Part number	Dimensions (mm)																	m (kg)	
		ØCK ¹⁾ H9	CL h16	CM A12	CO N9	FG js14	FL js12	FO js14	ØHB H13	KC +0.3	KL	LE min.	MR max.	RF js14	RG js14	ØS	SL	UK max.		UX max.
EMC-085-HD	R156330102	32	70	32	25	14.5	65	6	17.5	5.4	13	43	32	110	110	26	87	145	145	4.5
EMC-125-HD	R156350102	50	110	50	36	25.0	95	-	26.0	8.4	19	65	50	165	150	40	133	215	200	13.5

¹ Matching pivot pin Ø m6 (pin and pin locking feature are included in the scope of supply and are not ready-mounted on delivery)

Clevis bracket CLCD (comparable with ISO 8132), form A, with load measuring pin

Group 1/6, option 31

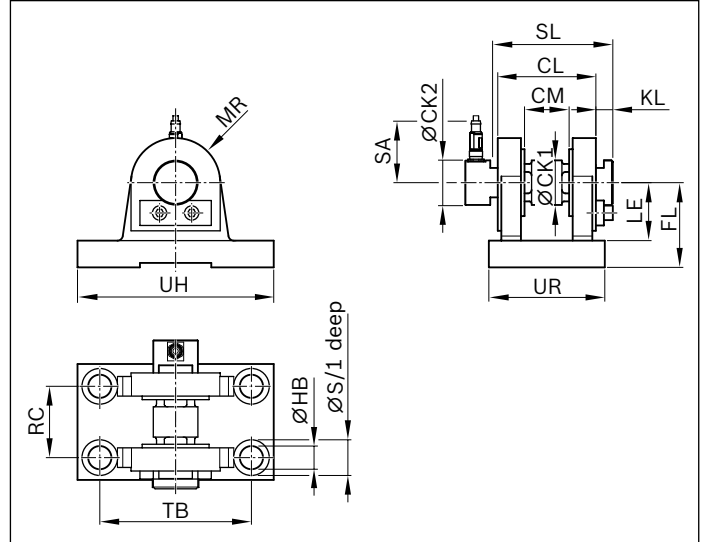
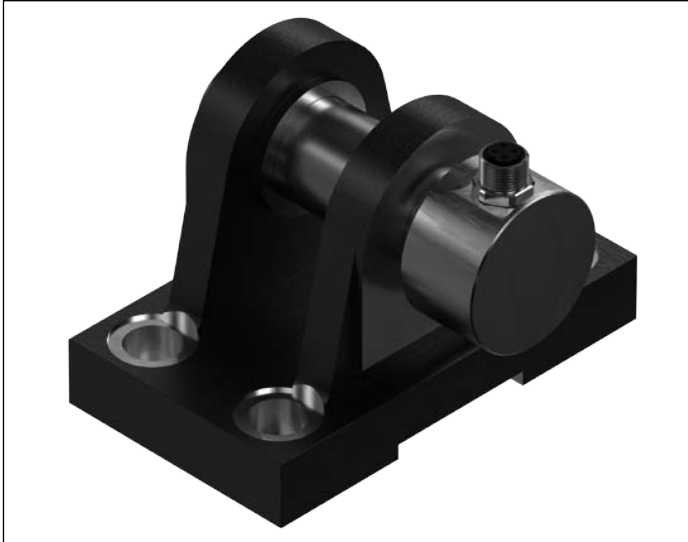

Size	Part number	Dimensions (mm)															m (kg)	
		ØCK1 ¹⁾ H9	ØCK2	CL h16	CM A12	FL js12	ØHB H13	KL ²⁾	LE min.	MR max.	RC js14	ØS	SL ²⁾	TB js14	UR max.	UH max.		SA
EMC-085-HD	R156330103	32	50	70	32	65	17.5	12	43	32	50	26	117.0	110	85	143	69.5	3.35
EMC-125-HD	R156350103	50	50	110	50	95	26.0	20	65	50	80	40	166.5	170	130	220	69.5	11.05

¹ Matching pivot pin Ø f8. For detailed information on the load measuring pin see “Load Sensor” section.

² Values deviate from ISO 8132 standard

Mounting Elements

Threaded mounting interface for version without integrated anti-twist feature

Group 2, option 01

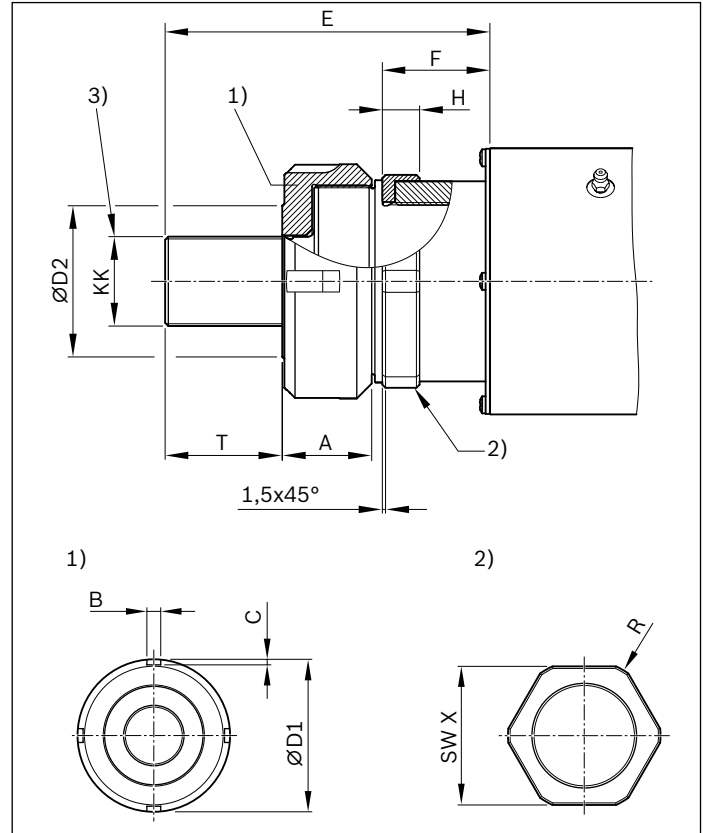

- 1) Lock nut on threaded mounting interface
- 2) Wrench flats for supporting the drive torque
- 3) Fastening thread for absorbing tensile/compressive forces

Size	Dimensions (mm)							Lock nut	KK	H ¹⁾	R	T	SW X	Weight (kg)
	A	B	C	ØD1	ØD2	E ²⁾	F ²⁾							
EMC-085-HD	31	8	4	77	41	116.5	42.5	M60x1.5	M27x2	14.0	R36	37	65	3.0
EMC-125-HD	42	10	4	110	71	152.5	50.5	M90x2	M42x2	17.5	R55	56	100	10.6

- 1) Maximum dimension of customer-built attachment
- 2) Dimensions E and F are shown in retracted state (stroke = 0 mm)!

Notes for mounting

The wrench flats provide positive-locking support for the drive torque.
 Tensile and compressive axial forces are absorbed via the fastening thread.
 During installation, screw the lock nut all the way onto the threaded mounting interface.
 After screwing on and radially aligning the connection element, screw back the lock nut against the connection element (maximum 1.5 turns).
 The lock nut is not intended to fix the customer's attachment axially against at the wrench flats.

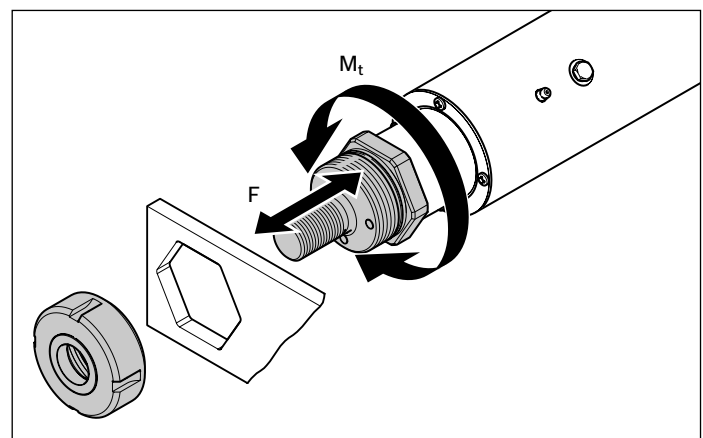

Spherical rod end bearing CGKD (clampable) with clevis
Group 2, option 02

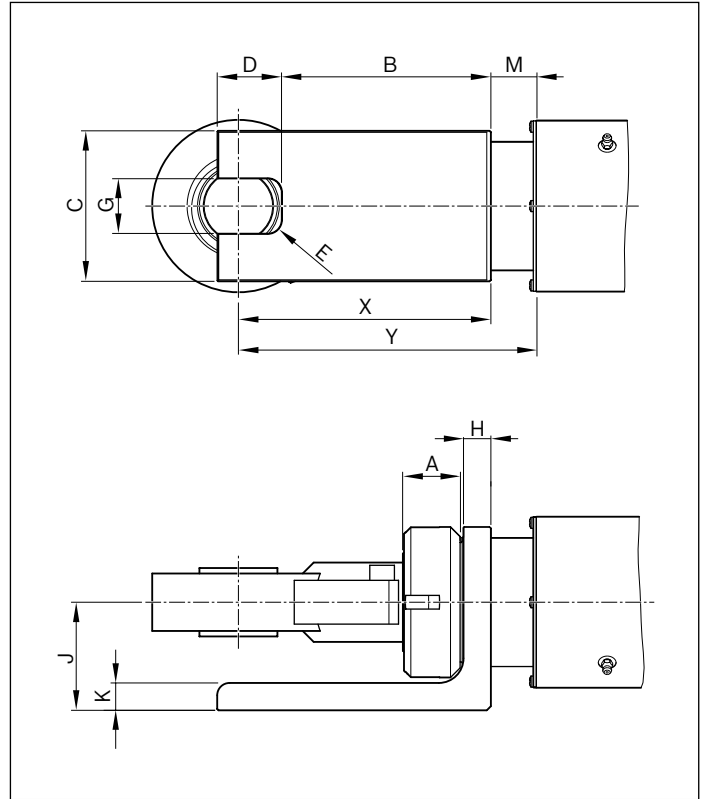
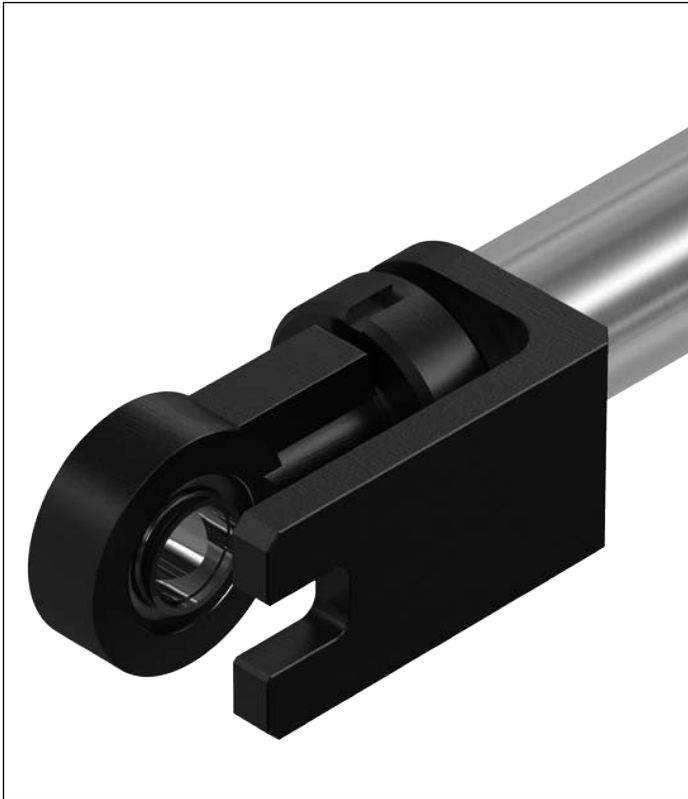

Size	Dimensions (mm)												m (kg)
	A	B	C	D	E	G H7	H	J	K	M ¹⁾	X	Y ¹⁾	
EMC-085-HD	31	114	75	34	R6	25	15	62	15	28.5	131-134	159.5-162.5	1.6
EMC-125-HD	42	153	110	47	R10	40	20	79	15	33.0	183.5-186.5	216.5-219.5	4.1

¹ Dimensions M and Y are shown in retracted state (stroke = 0 mm)!

Note

The matching pivot pin is included with the clevis bracket for spherical rod end bearing with clevis (group 1, option 11). Customer-built connection elements dimensions analog to clevis brackets (group 1, option 11).

Mounting Elements

Threaded mounting interface for version with integrated anti-twist feature

Group 2, option 11

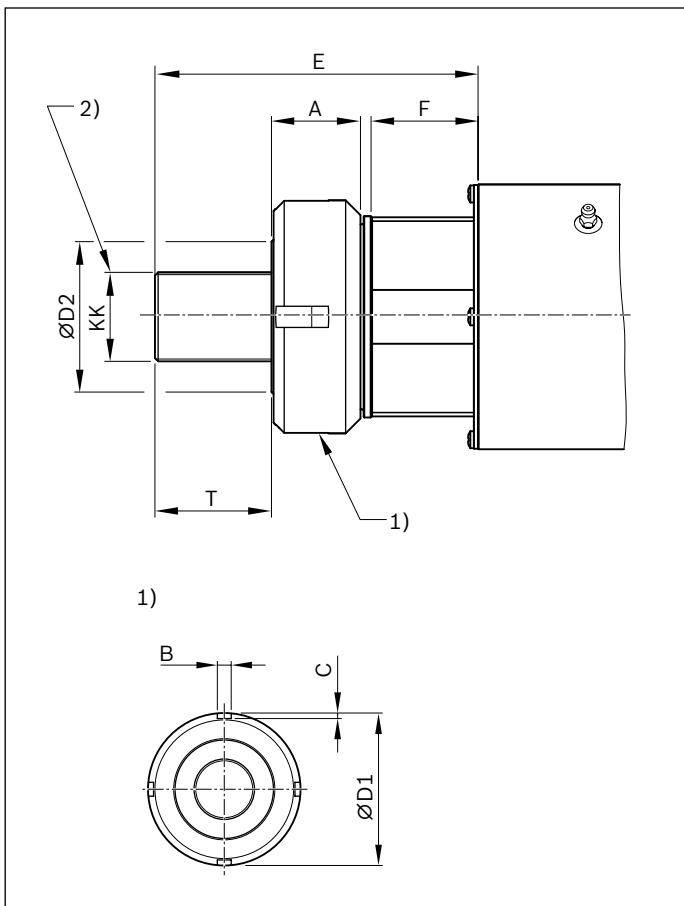
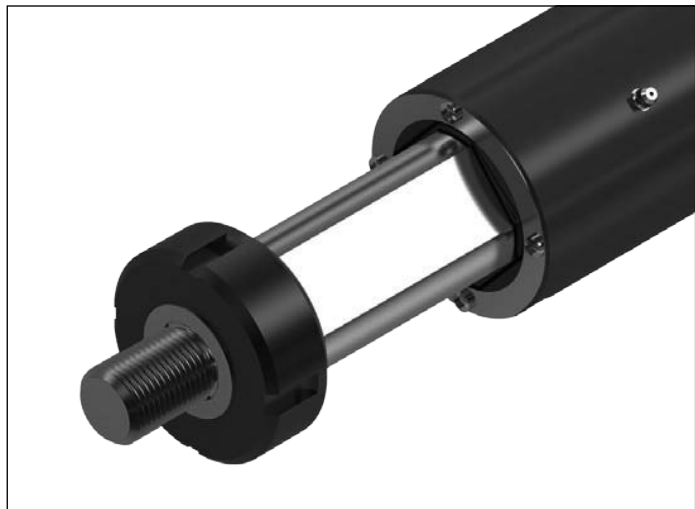

- 1) Lock nut on threaded mounting interface
2) Fastening thread for absorbing tensile/compressive forces

Size	Dimensions (mm)						E ¹⁾	F ¹⁾	Lock nut	KK	T max.
	A	B	C	ØD1	ØD2						
EMC-085-HD	31	8	4	77	41	116.5	42.5	M60x1.5	M27x2	37	
EMC-125-HD	42	10	4	110	71	152.5	50.5	M90x2	M42x2	56	

1 Dimensions E and F are shown in retracted state (stroke = 0 mm)!

Notes for mounting

The drive torque is absorbed via the integrated anti-twist feature.

Tensile and compressive axial forces are absorbed via the fastening thread.

During installation, screw the lock nut all the way onto the threaded mounting interface.

After screwing on and radially aligning the connection element, screw back the lock nut against the connection element (maximum 1.5 turns).

Spherical rod end bearing CGKD (clampable)
Group 2, option 12

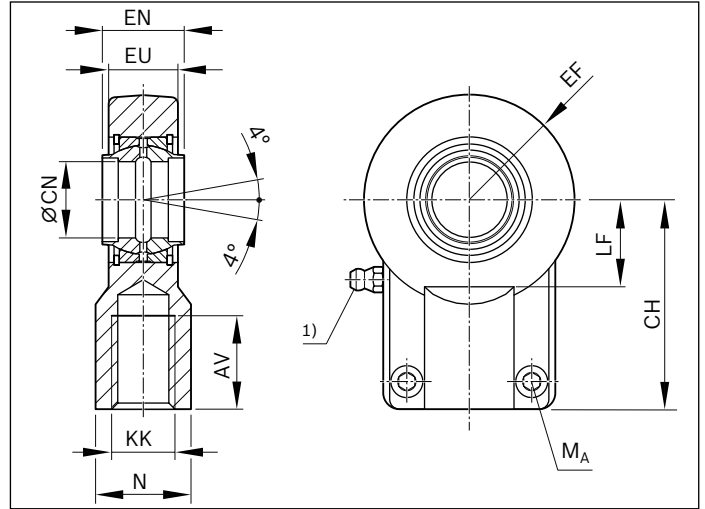

1) Lube nipple, hydraulic type A as per DIN 71412

Size	Part number	Dimensions (mm)									Clamping screw ISO 4762-10.9	M _A (Nm)	Weight (kg)
		AV min.	N max.	CH js13	EF max.	ØCN ¹⁾ H7	EN h12	EU max.	KK	LF min.			
EMC-085-HD	R900322049	37	38	80	40	32	32	28	M27x2	30	M10x25	59	1.15
EMC-125-HD	R900322719	57	58	120	63	50	50	42	M42x2	47	M12x35	100	4.00

1 Matching pivot pin Ø m6

Notes for mounting

During installation, screw the lock nut all the way onto the threaded mounting interface.

After screwing on and radially aligning the connection element, screw back the lock nut against the connection element (maximum 1.5 turns).

Then tighten clamping screws to the stated tightening torque.

Mounting Elements

Foot mount

Group 3, option 11

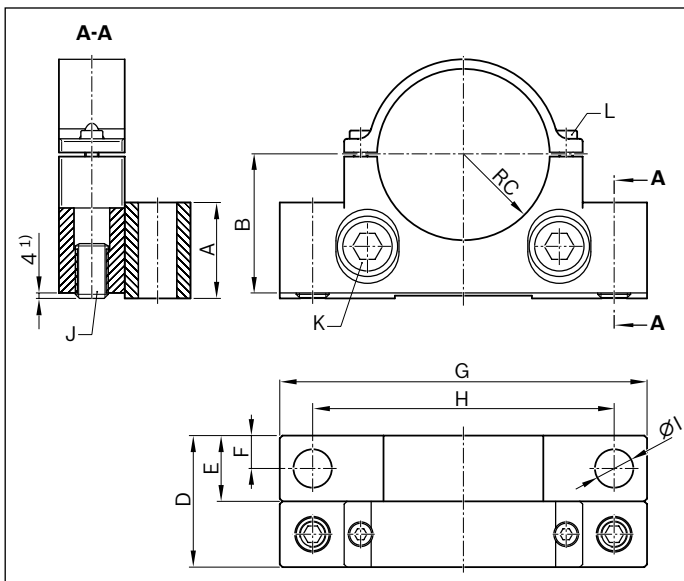

Size	Part number	Dimensions (mm)									J Set screw ISO 4026	K Screw ISO 4762	L Screw ISO 4762	m (kg)
		A	B	RC	D	E	F	G	H	ØI				
EMC-085-HD	R156330130	55	61.5	43	60	32	16	195	162	19	M16X40	M16x40	M8x20	1.4
EMC-125-HD	R156350130	70	101.5	63	96	48	24	268	220	28	M24X40	M24x70	M10x25	4.7

1 The foot mount can be adjusted for height in a range of +/- 4 mm

Note

This fastening element is only suitable for supporting the housing tube when the cylinder is installed horizontally. It is not designed to absorb axial forces!

Swivel bearing
Group 5, option 11

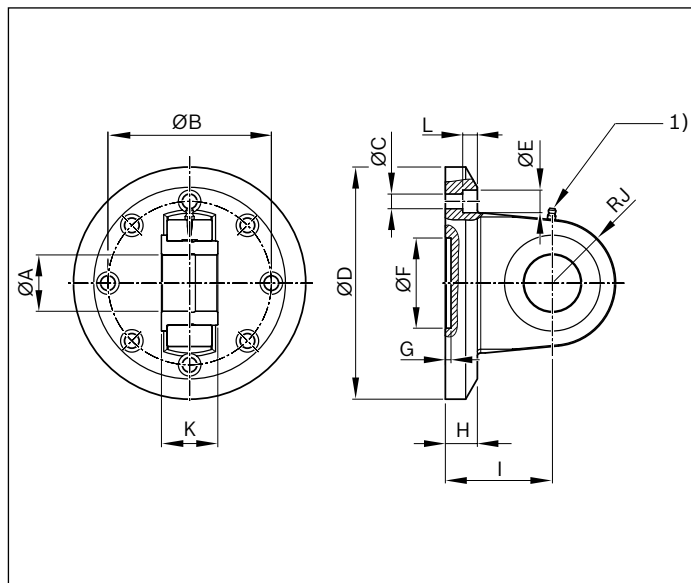

1) Lube nipple, hydraulic type A as per DIN 71412

Size	Part number	Dimensions (mm)											m (kg)	
		ØA H9	ØB	ØC	ØD	ØE	ØF H7	G	H max.	I	RJ	K h12		L
EMC-085-HD	R156330150	32	100	9	162	15	60	5	22.7	65	39	32	9	4.1
EMC-125-HD	R156350150	50	145	13	206	20	80	5	28.4	95	56	50	13	10.8

Mounting Elements

Trunnion bearing block CLTB

Group 6, option 01

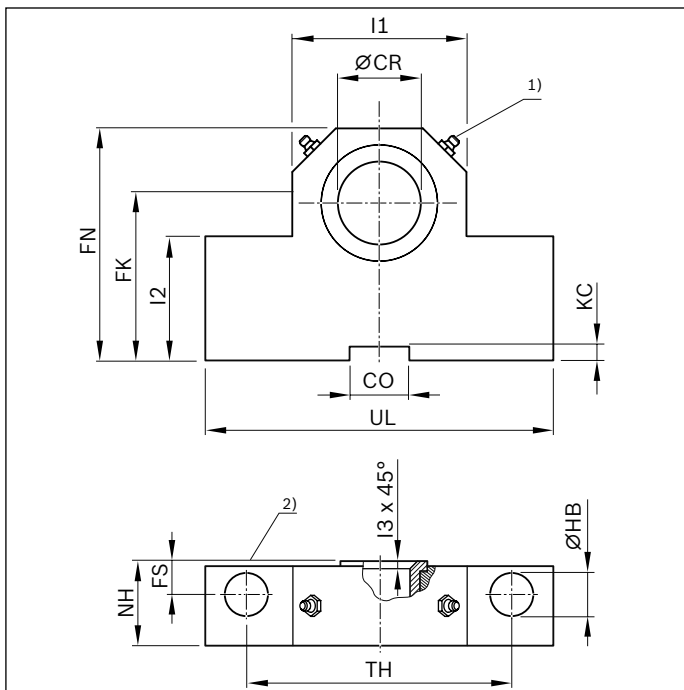
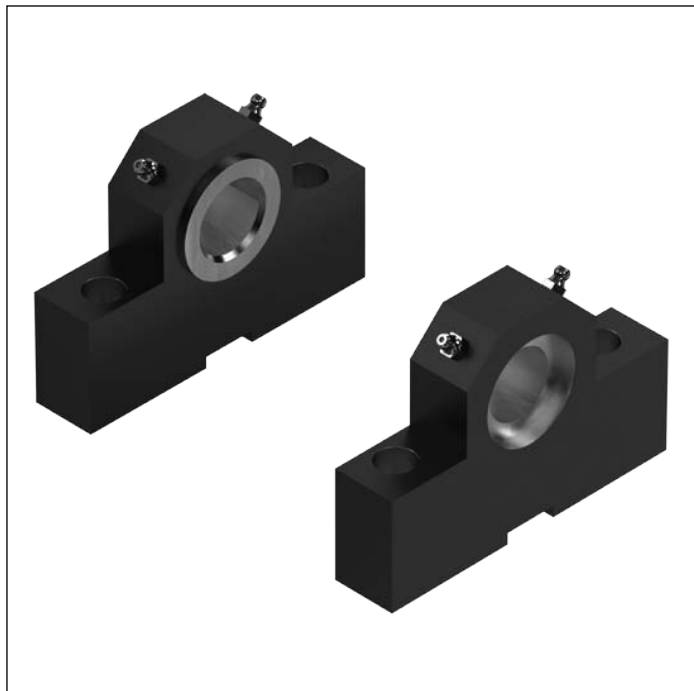

- 1) Lube nipple, hydraulic type A as per DIN 71412
2) Trunnion location face (inside)

Size	Part number	Dimensions (mm)													m ¹⁾ (kg)
		ØCR H7	CO N9	FK js12	FN max.	FS js14	ØHB H13	KC +0.3	I1	I2	I3	NH max.	TH js14	UL max.	
EMC-085-HD	R156330160	32	25	65	100	15	17.5	5.4	70	52	2.5	33	110	150	4.55
EMC-125-HD	R156350160	50	36	95	140	20	26.5	8.4	100	75	2.5	51	160	210	14.50

1) Figure per pair

Note

Trunnion bearing blocks are always supplied in pairs.

Round flange

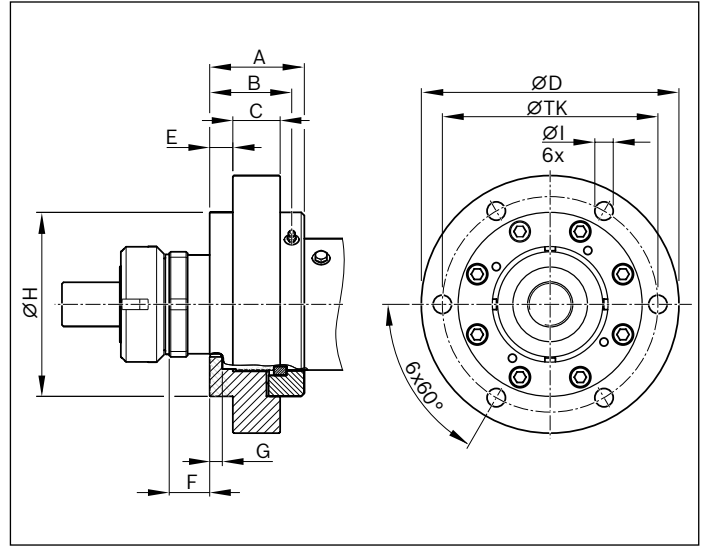
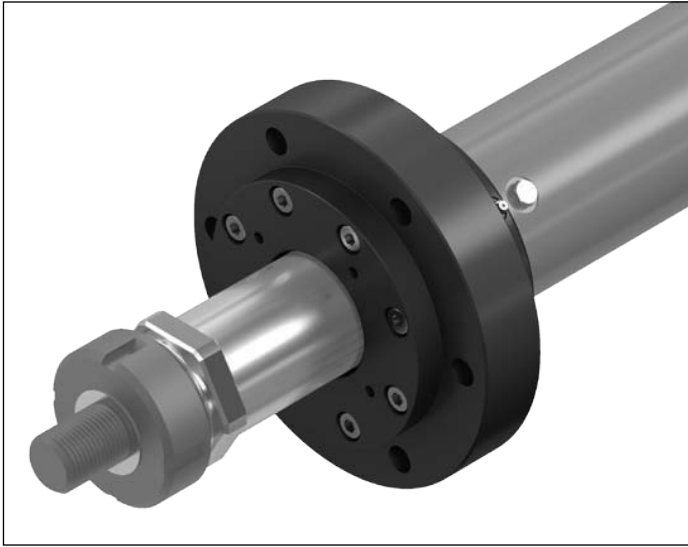

Size	Dimensions (mm)										
	ØTK	ØD	A	B	C	E	F	G	ØH	ØI	m (kg)
EMC-085-HD	155	185	76	66	35	15	32.5	10	130	13.5	8.2
EMC-125-HD	205	245	90	78	45	22	38.5	12	175	17.5	15.8

Note

This type of mounting is only suitable for vertical installation.

Load Sensor

Clevis bracket with load measuring pin

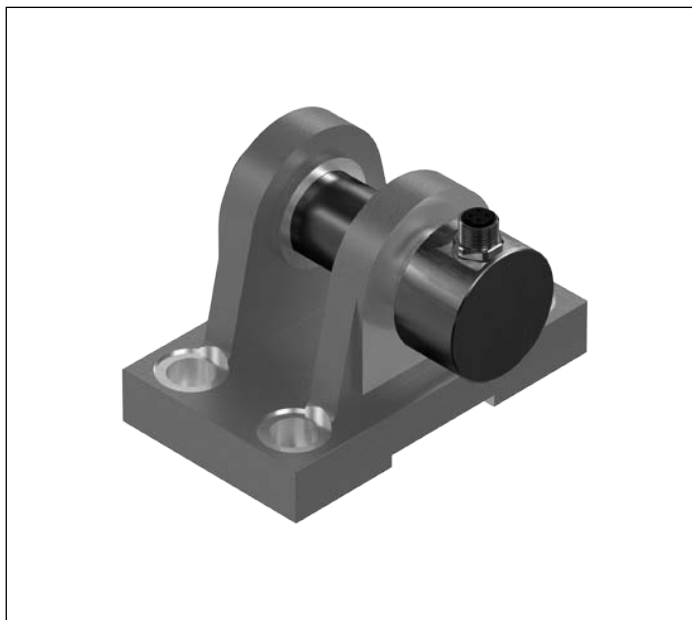

Load measuring pin for

Size	Part number	Measuring range
EMC-085-HD	R156337080	50 kN
EMC-125-HD	R156357080	110 kN

Technical data

Metrological specifications

Material	Stainless steel
Protection class	IP 65
Hardness (load sensing range)	38 HRC
Mechanical system	
Operating load	150% of MR
Load at fracture	300% of MR
Accuracy	
Non-linearity	±0.5% of MR
Repeatability	±0.25% of MR
Hysteresis	±0.2% of MR
Temperature drift at zero point	±0.05% of MR/K
Temperature drift over measuring range	±0.05% of MR/K
Compensated temperature	+10 ... +40 °C
Operating temperature	-20 ... +60 °C

MR = measuring range

MR/K = measuring range per Kelvin

If your application requires precise load sensing, there is a clevis bracket version with load measuring pin available for this purpose. This option can be selected both at the piston rod end connected to the spherical rod end bearing, and at the timing belt side drive connected to the swivel bearing. Thanks to the thin-film technology used, the load cells are very robust and stable over the long term. The load cells are compliant with the EN 61326 standard for electromagnetic compatibility (EMC) and are designed to sense both tensile and compressive forces.

Note

The use of a hammer or press to fit the pin is not permitted. It may only be inserted by hand.

The pin is not suitable for measuring torques and may therefore only be used with the cylinder option "Guideway with anti-twist feature".

It is secured axially and against twisting, like the standard pin, on one side of the bracket using the pin locking feature supplied.

For force control at the controller level, a control unit with an analog input is required.

Electrical specifications

Output signal	0 kN	0±0.03 V
Output signal	MR	-10 ... 10 V ±0.2 V
Power supply		19 ... 28 V
Current consumption		50 mA (24 V)
Bandwidth		2.5±0.2 KHz

Features

- ▶ For tensile and compressive forces
- ▶ Corrosion-resistant stainless steel version
- ▶ Integrated amplifier
- ▶ Low temperature coefficient
- ▶ High long term stability
- ▶ High shock and vibration resistance
- ▶ For dynamic or static measurements
- ▶ Good reproducibility
- ▶ Easy mounting

**Dimensions
for EMC-085-HD**

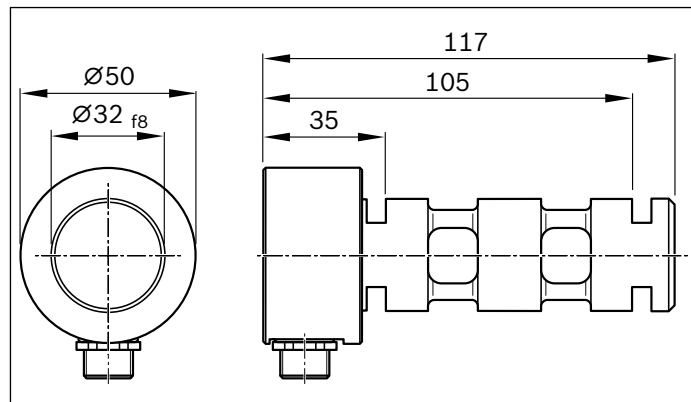

for EMC-125-HD

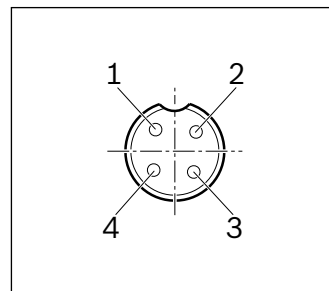
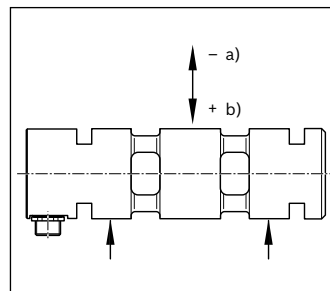
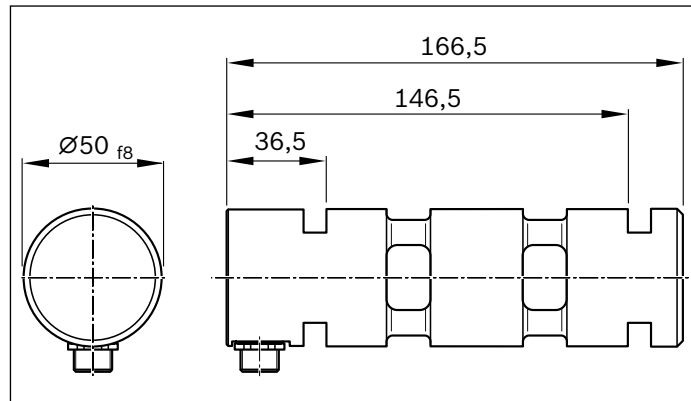

- 1** brn = brown, power supply (+)
- 2** wht = white, output
- 3** blu = blue, GND
- 4** blk = black, tare

Switch Mounting Arrangements

Proximity switches

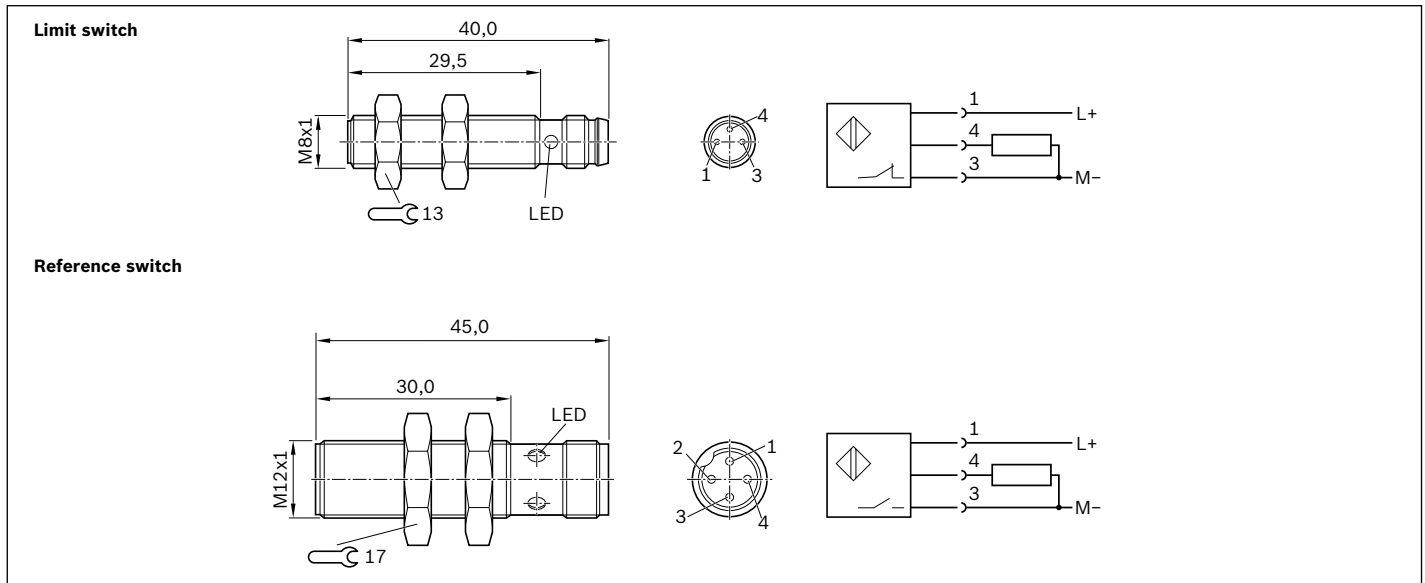



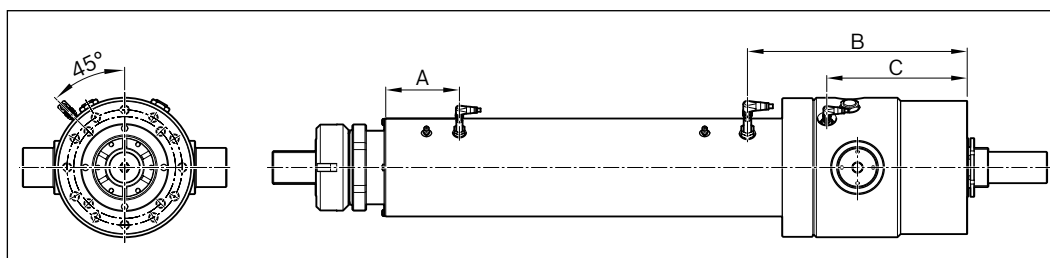

Technical data, proximity switches

	Limit switch	Reference switch
Part number	R9130 307 57	R9130 307 58
Function principle	Proximity	Proximity
Operating voltage	10 ... 30 V DC	10 ... 30 V DC
Load current	< 200 mA	< 200 mA
Switching function	PNP/normally closed (NC)	PNP/normally open (NO)
Connection type	Plug connector, M8x1, 3-pin	Plug connector, M12x1, 4-pin
Function indication	✓	✓
Short-circuit protection	✓	✓
Polarity safe	✓	✓
Switching frequency	3 kHz	2 kHz
Reproducibility	< 0.05 mm	< 0.05 mm
Max. perm. approach speed	1 m/s	1 m/s
Ambient temperature	-25 °C to +70 °C	-25 °C to +70 °C
Protection class	IP 68	IP 68
MTTFd (as per EN 13849)	835 years at 40 °C	835 years at 40 °C
Certification and approval		

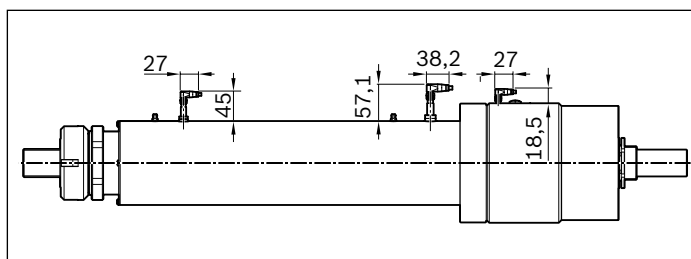
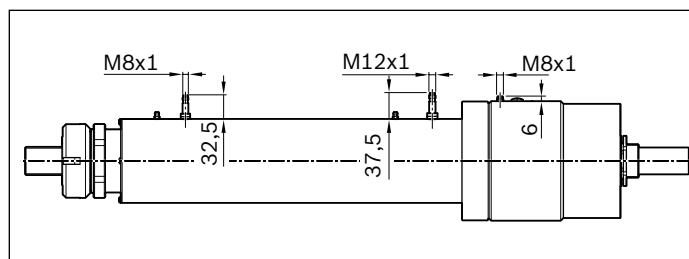
Switch position

Size	Dimensions (mm)		
	A	B	C
EMC-085-HD	91	210	135
EMC-125-HD	94	280	180

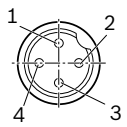
With connection cable

Without connection cable

Technical data, cables

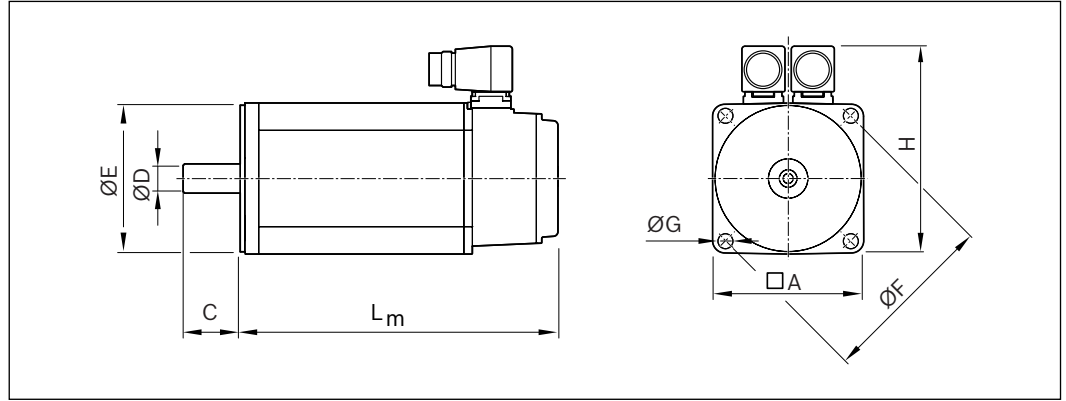
	Limit switch cable	Reference switch cable
Part number	R9873 914 96	R9130 233 89
Pin assignment	 1 brown 3 blue 4 black	 1 brown 3 blue 4 black
Type of cable	PUR black	PUR black
Length	5.0 m	5.0 m
Operating voltage	10 ... 30 V DC	10 ... 30 V DC
1. Connection type	Angled female connector, M8x1, 3-pin	Angled female connector, M12x1, 5-pin
2. Connection type	Flying lead	Flying lead
Function indication	–	✓
Operating voltage indicator	✓	✓
Suitable for flexing installation	✓	✓
Cable cross-section	3 x 0.34 mm ²	3 x 0.34 mm ²
Cable diameter D	4.3 ± 0.2 mm	4.3 ± 0.2 mm
Bending radius, stationary	> 5 x D	> 5 x D
Bending radius, flexing	> 10 x D	> 10 x D
Flexing cycles	> 2 million	> 2 million
Max. perm. travel speed	3.3 m/s	3.3 m/s
Max. perm. acceleration	5 m/s ²	5 m/s ²
Ambient temperature fixed & moving	–25 °C to +80 °C	–25 °C to +80 °C
Ambient temperature, flexing installation	–25 °C to +60 °C	–25 °C to +60 °C
Protection class	IP 68	IP 68
Certification and approval		

IndraDyn S – Servo Motors MSK



Motor connector is orientated in direction of motor shaft

Motor	Dimensions (mm)									
	A	C	ØD	ØE	ØF	ØG	H	L _m	Without holding brake	With holding brake
MSK 071D-0300	140	58	32	130	165	11	202		312	347
MSK 100B-0300	192	60	32	130	215	14	262		368	368
MSK 101D-0300	192	80	38	180	215	14	262		410	410
MSK 101E-0300	192	80	38	180	215	14	262		501	501

Motor data

Motor	n _{max}	M ₀	M _{max}	M _{br}	J _m	J _{Br}	m _m	m _{br}
	(min ⁻¹)	(Nm)	(Nm)	(Nm)	(kgm ²)	(kgm ²)	(kg)	(kg)
MSK 071D-0300	3 800	17.5	66.0	Without	0.00230	-	18.0	-
MSK 071D-0300		17.5	66.0	23	0.00230	0.00030	18.0	1.6
MSK 100B-0300	4 500	28.0	102.0	Without	0.01920	-	34.0	-
MSK 100B-0300		28.0	102.0	32	0.01920	0.00124	34.0	2.5
MSK 101D-0300	4 600	50.0	160.0	Without	0.00932	-	40.0	-
MSK 101D-0300		50.0	160.0	70	0.00932	0.00300	40.0	3.8
MSK 101E-0300		70.0	231.0	Without	0.01380	-	53.5	-
MSK 101E-0300		70.0	231.0	70	0.01680	0.00300	53.5	3.8

- J_{br} = mass moment of inertia of holding brake
- J_m = mass moment of inertia of motor
- L_m = length of motor
- M₀ = standstill torque
- M_{br} = holding torque of holding brake when switched off

- M_{max} = maximum possible motor torque
- m_m = mass of motor
- m_{br} = mass of holding brake
- n_{max} = maximum rotary speed

Motor torque speed curve

(schematic)

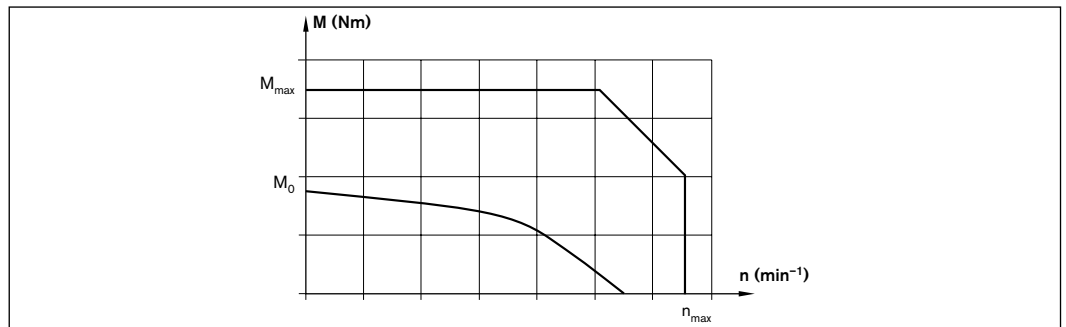

Option number ¹⁾	Motor	Part number	Version		Type designation
			Holding brake Without	With	
114	MSK 071D-0300	R911310539	X		MSK071D-0300-NN-M1-UG0-NNNN
115		R911310168		X	MSK071D-0300-NN-M1-UG1-NNNN
116	MSK 100B-0300	R911315705	X		MSK100B-0300-NN-M1-AG0-NNNN
117		R911310478		X	MSK100B-0300-NN-M1-AG1-NNNN
118	MSK 101D-0300	R911315888	X		MSK101D-0300-NN-M1-AG0-NNNN
119		R911310895		X	MSK101D-0300-NN-M1-AG2-NNNN
120	MSK 101E-0300	R911317226	X		MSK101E-0300-NN-M1-AG0-NNNN
121		R911310891		X	MSK101E-0300-NN-M1-AG2-NNNN

¹ From "Configuration and Ordering" table

Version:

- Plain shaft with shaft seal
- Multi-turn absolute encoder M1 (Hiperface)
- Cooling system: natural convection
- Protection class IP 65 (casing)
- With or without holding brake

Note

The motors can be supplied complete with controllers and control systems. For further motor types and more information on motors, controllers and control systems, please refer to the following Rexroth catalogs on drive technology:

- Drive System Rexroth IndraDrive, R999000018
- Rexroth IndraDyn S Synchronous Motors MSK, R911296288
- Rexroth IndraDrive C Drive Controllers with HCS02 and HCS03, R911314904
- HCS03 (see "General product description; motor-controller combination")

Recommended motor/ controller combinations

Motor	Controller ¹⁾	Controller ²⁾
MSK 071D-0300	HCS02.1E-W0070	HCS02.1E-W0028
MSK 100B-0300	HCS03.1E-W0100	HCS02.1E-W0054
MSK 101D-0300	HCS03.1E-W0150	HCS03.1E-W0100
MSK 101E-0300	HCS03.1E-W0210	HCS03.1E-W0100

1) Design for maximum current / maximum torque of the motor

If the acceleration torque is not required, a drive controller 1-2 power ratings lower may also be adequate.

2) Design for continuous current at standstill / continuous torque at standstill of the motor

The relevant DC bus continuous power and increased current demand on acceleration are to be taken into account!

Due to the need to take into account the drive controller's power and the effect of accessories (mains choke), detail design is essential in any case.

Operating Conditions and Usage

Normal operating conditions

Ambient temperature, cylinder with Rexroth servo motor	0 °C ... 40 °C, above 40 °C loss of performance
Ambient temperature cylinder mechanical system	-10 °C ... +50 °C (up to +60 °C with low duty cycle and power)
Ambient temperature cylinder mechanical system with PLSA and low-temperature grease	-30 °C ... +50 °C (up to +60 °C with low duty cycle and power)
Protection class	IP 65
Duty cycle	100% (depending on power required, the permissible duty cycle may be limited due to heat generation)

Design notes

- Moved parts: safety devices and guards necessary
- For vertical installations: arresting devices necessary to protect against falling loads

Intended use

The product is an assembly.

The product may be used in accordance with the technical documentation (product catalog) for the following purposes:

- for precise positioning in space.

The product is intended exclusively for professional use and not for private use. Use for the intended purpose also includes the requirement that you must have read and understood the product documentation completely, in particular the “Safety Instructions for Linear Motion Systems”.

The product is exclusively intended for incorporation into a final machine or a system or for assembly to other components for the purpose of building a final machine or a system.

Misuse

Use of the product in any other way than as described under “Intended use” is considered to be misuse and is therefore not permitted. If unsuitable products are installed or used in safety-relevant applications, this may lead to uncontrolled operating statuses in the application which can cause personal injury and/or damage to property.

The product may only be used in safety-relevant applications if this use has been expressly specified in the product documentation and is permitted, e.g. in zones with potentially explosive atmospheres or in safety-critical parts of a control system (functional safety). Bosch Rexroth AG will not accept any liability for injury or damage caused by misuse of the product. The risks associated with any misuse of the product shall be borne by the user alone.

Misuse of the product includes:

- the transport of persons

Nameplate

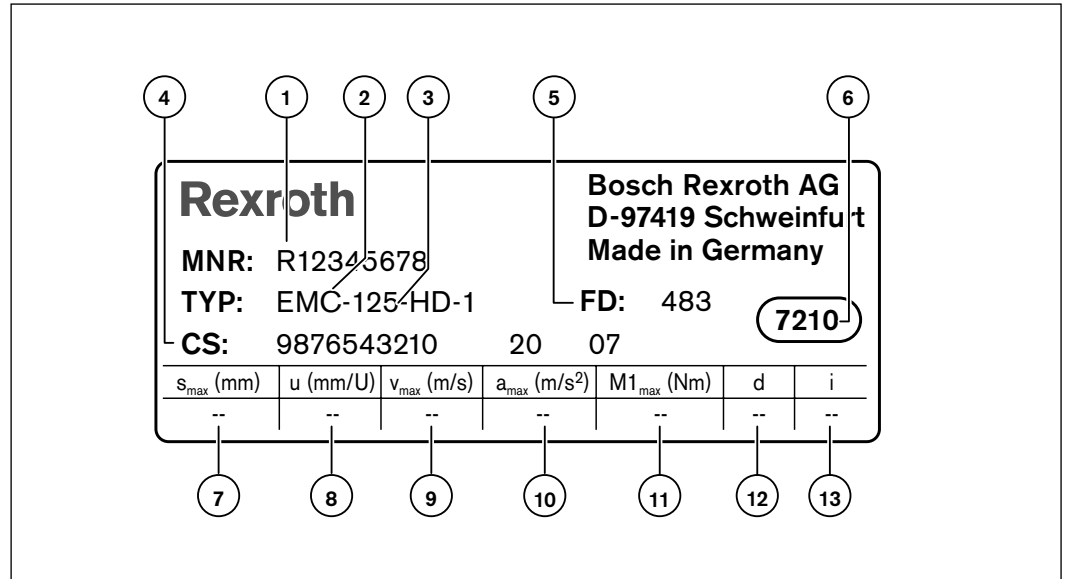

1	MNR	Part number
2	TYPE	Short product name
3	125	Size
4	CS	Customer information
5	FD	Date of manufacture
6	7210	Manufacturing location
7	s_{\max}	Maximum travel range
8	u	Lead constant without motor attachment
9	v_{\max}	Maximum linear speed
10	a_{\max}	Maximum acceleration
11	$M1_{\max}$	Maximum drive torque at motor journal
12	d	Direction of rotation of the motor for travel in positive (+) direction
13	i	Gear ratio

Note

The stated values describe the mechanical limits of the axis.

Lubrication and Maintenance

Grease lubrication

The advantage of grease lubrication is that the ball or planetary screw assemblies can run long distances on one supply of grease. As a result, a lubricating system is not required in many cases.

All commercially available high-quality ball bearing lubricating greases may be used. Read the lubricant manufacturer's specifications carefully! Greases in accordance with DIN 51825 K2K and, for higher loads, KP2K of NLGI Class 2 in accordance with DIN 51818 are recommended for the longest possible lubrication intervals. Tests have shown that greases of NLGI Class 00 achieve only about 50% of the running performance of Class 2 at higher loads.

The relubrication interval depends on many factors such as the degree of contamination, operating temperature, load, etc. The following values can thus serve only as a guide.

Lubrication position and notes on lubrication

Basic lubrication is applied in-factory before shipment. The electromechanical cylinders are designed for grease lubrication. Screw drives and guideway must be relubricated. During this process lubricant must be applied to all lubrication points. To reach the lubrication positions X1 and X2, move the piston rod to stroke position S2 (reference position), see figure:

- With limit switch fitted, move by S1
- Without limit switch, move by S1 + 8 mm from the rear end position.

For more information, see "Instructions for EMC-HD, R320103139".

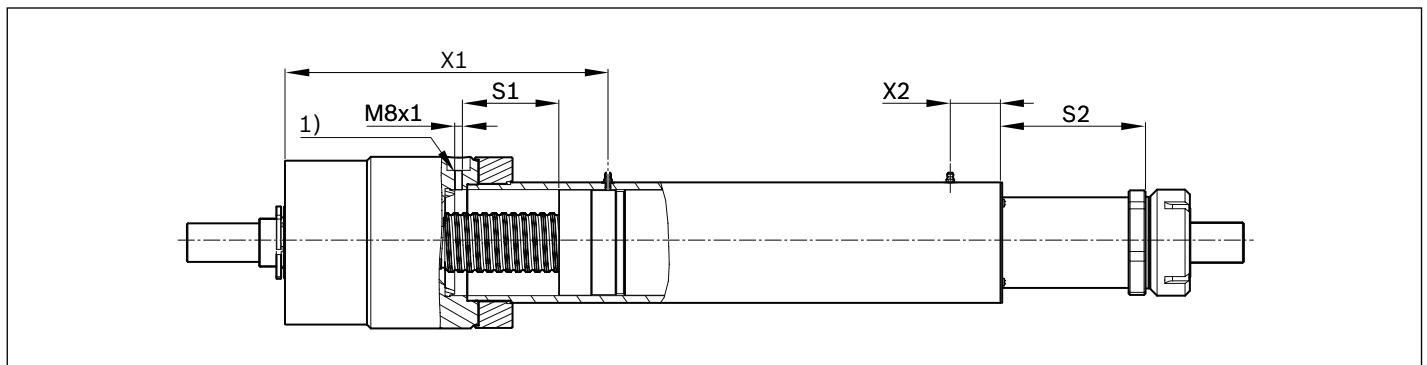
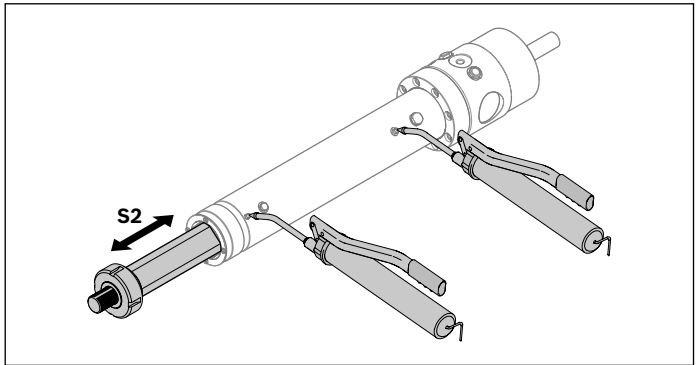

1) Limit switch bore

Size	X1 (mm)	X2 (mm)	S1 (mm)	S2 (mm)
EMC-085-HD	256	52	75	117
EMC-125-HD	335	52	100	150

Recommended lubricants

Note

Do not use greases with solid lubricant components (e.g. graphite or MoS₂ additives).

Dynalub 520 is recommended for centralized lubrication systems.

Grease		Low-temperature grease (-30 ... +60 °C)
Consistency class NLGI 2 as per DIN 51818 We recommend Dynalub 510 (Bosch Rexroth) Cartridge (400 g) R341603700 Bucket (5 kg) R341603500	Consistency class NLGI 00 as per DIN 51818 We recommend Dynalub 520 (Bosch Rexroth) Cartridge (400 g) R341604300 Bucket (5 kg) R341604200	Klüber BEM 34-132 R341603600
May also be used Elkalub GLS 135 / N2 (Chemie-Technik) Castrol Longtime PD2 (Castrol)	May also be used Elkalub GLS 135 / N00 (Chemie-Technik) Castrol Longtime PD 00 (Castrol)	

Documentation

Standard report
Option 01

The standard report serves to confirm that the checks listed in the report have been carried out and that the measured values lie within the permissible tolerances.

Checks listed in the standard report:

- Functional checks on mechanical components
- Functional checks on electrical components
- Design in accordance with order confirmation

Frictional torque of the complete system

Option 02

All items contained in the standard report.
The moment of friction M is measured over the entire travel range.

Example

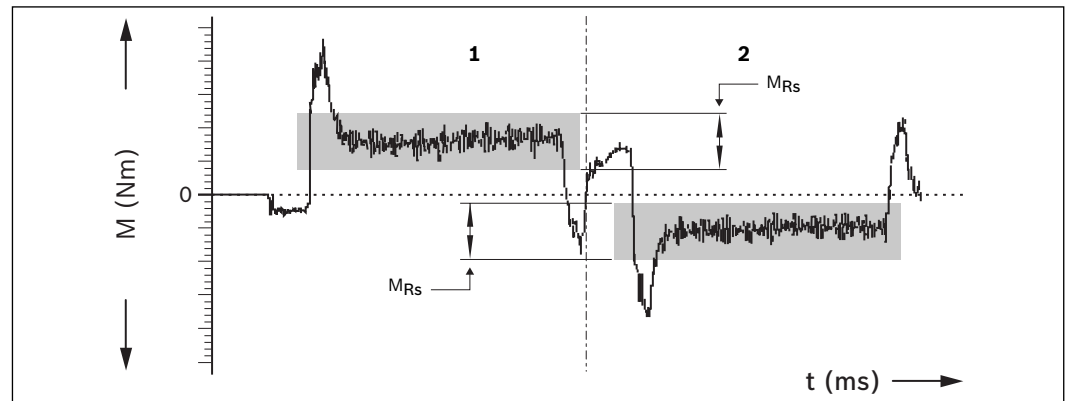

- 1) Advance
- 2) Return

M_{Rs} = frictional torque (N)
 t = travel time (ms)

Lead deviation of screw drive

Option 03

All items contained in the standard report.
In addition to graphical representation (see illustration), a measurement report is supplied in table form.

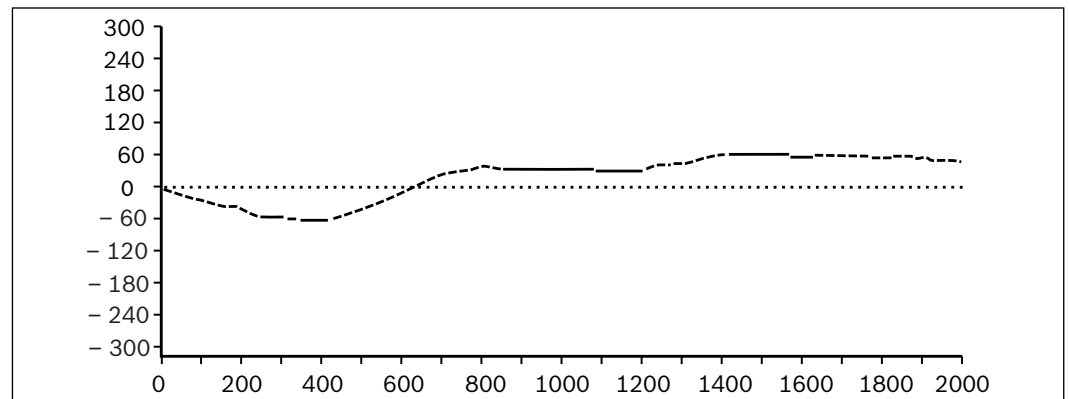

Further Information

Here you will find extensive information on products, eShop, safety engineering, and training and services offered.

Product information:

<http://www.boschrexroth.com/dcl>

- 1 Instructions and catalogs in PDF format and 3D CAD generator
- 2 Printed catalogs and other publications
- 3 Configurator

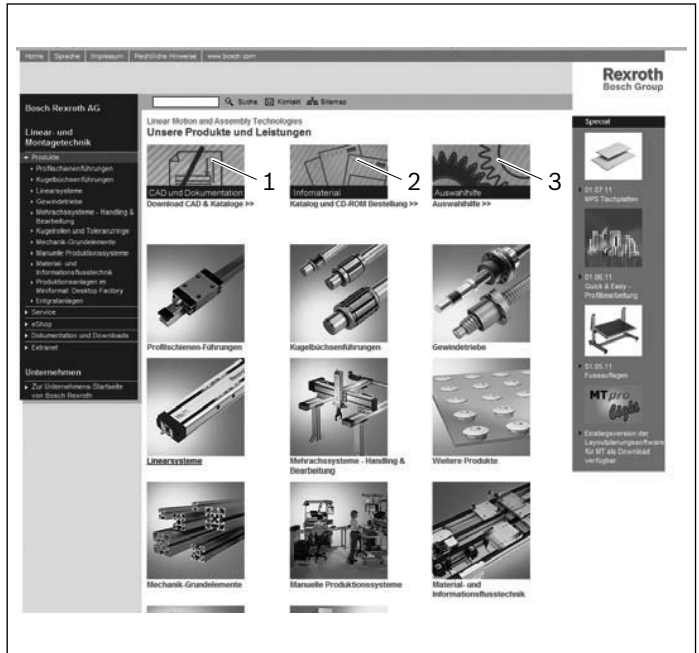

eShop:

<http://www.boschrexroth.com/eshop>



Rexroth 4EE - Rexroth for Energy Efficiency:

<http://www.boschrexroth.com/4EE>

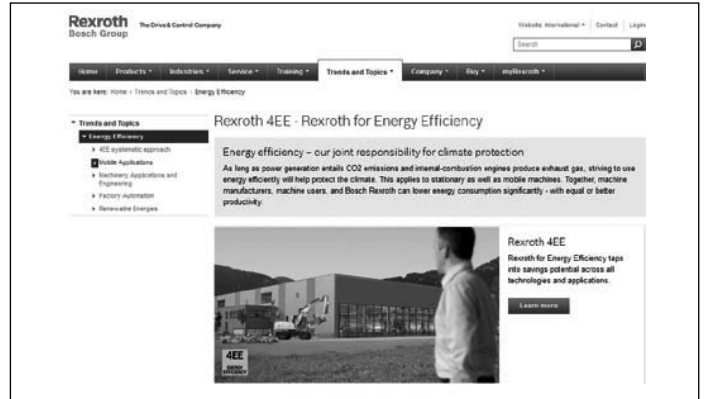

Safety engineering:

<http://www.boschrexroth.com/Maschinensicherheit>



Training:

<http://www.boschrexroth.com/training>



Service:



<http://www.boschrexroth.com/service>

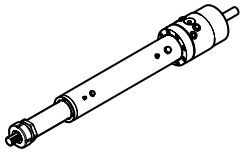
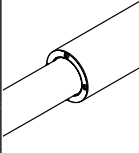
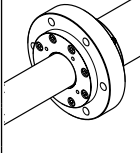
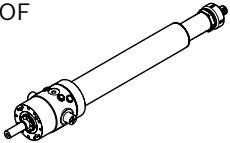
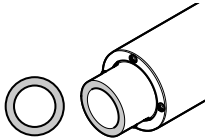
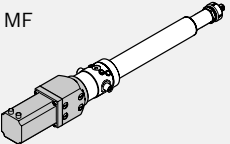
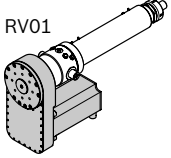
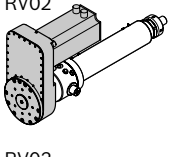
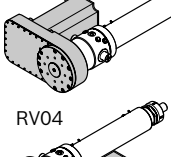
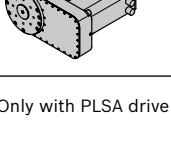

Ordering Example EMC-125-HD

Short product name, s_{max} EMC-125-HD-1, ... mm	Guideway		Drive units				Lubrication		Version
	Without round flange	With round flange	PLSA $d_0 \times P$		Ball screw $d_0 \times P$		With initial greasing	Prelubricated with low-temperature grease	
			48 x 5	48 x 10	63 x 10	63 x 20	With initial greasing	Prelubricated with low-temperature grease	Description
Without anti-twist feature	01	02	01	02	12	13	01	02 ¹⁾	Without motor mount OF 
									With motor mount MF 
With anti-twist feature	11	12							With timing belt side drive (SD) RV01  RV02  RV03  RV04 

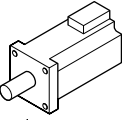
1) Only with PLSA drive

Gear ratio	Motor attachment		Motor			Switches				Surface finish		Documentation		
	 Description		 Without brake With brake			Without switch	1 reference switch	2 limit switches	2 limit switches and 1 reference switch	Standard	Black painted	Standard report	 Measurement report	
	Without	00	Without	000	000									
i = 1	With motor mount	02	MSK 100B	116	117	00	01	02	03	01	13	01	02 ²⁾	03 ³⁾
		03	MSK 101D	118	119									
			MSK 101E	120	121									
i = 3	With motor mount and gear unit	06	MSK 100B	116	117									
		07	MSK 101D	118	119									
			MSK 101E	120	121									
i = 5	With motor mount and gear unit	16	MSK 071D	114	115									
i = 1.5	Timing belt side drive	41	MSK 100B	116	117									
		42	MSK 101D	118	119									
			MSK 101E	120	121									
i = 4.5	SD (i = 1.5) and gear unit (i = 3)	51	MSK 100B	116	117									
		52	MSK 101D	118	119									
i = 7.5	SD (i = 1.5) and gear unit (i = 5)	70	MSK 071D	114	115									

2) Frictional torque measurement

3) Lead deviation

Ordering Example EMC-125-HD

Mounting elements

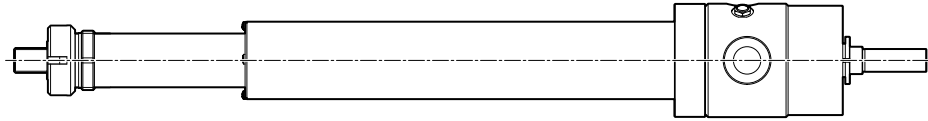

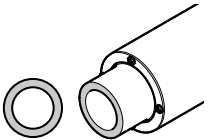
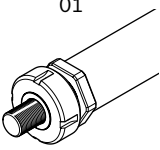
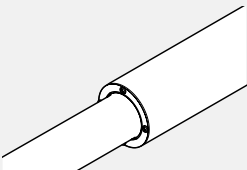
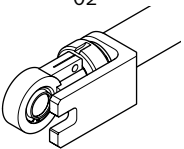
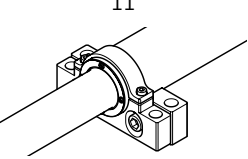
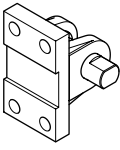
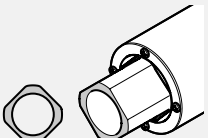
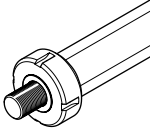
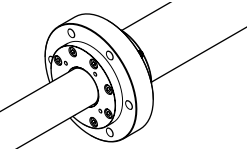
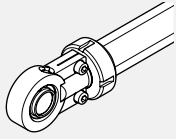
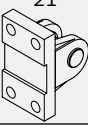
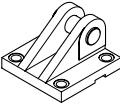
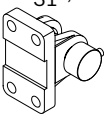
Version	Group 1	Group 2	Version	Group 3
Without anti-twist feature 	00	01 	Without round flange 	00
	00	02 		11 
	11 			
With anti-twist feature 	00	11 	With round flange 	00
	00	12 		
	21 			
	22 			
	31 ¹⁾ 			

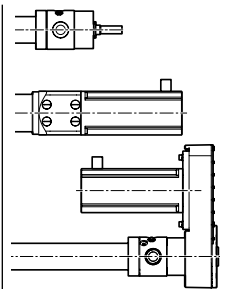
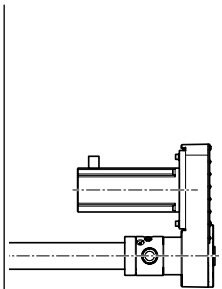
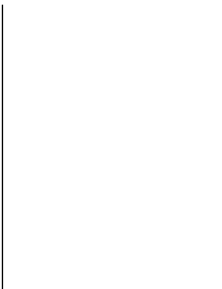
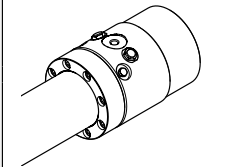
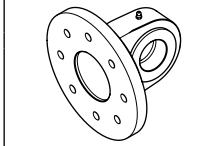
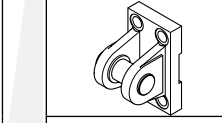
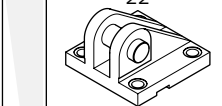
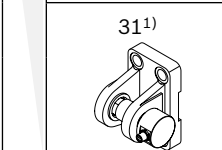
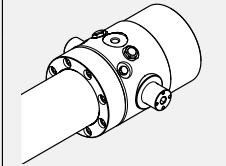
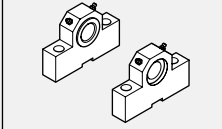
		
Group 4	Group 5	Group 6
<p>01</p> 	<p>00</p> <p>11</p> 	<p>00</p> <p>00</p> <p>21</p>  <p>22</p>  <p>31¹⁾</p> 
<p>02</p> 	<p>00</p>	<p>00</p> <p>01</p> 
<p>01</p>	<p>00</p>	<p>00</p>

Ordering example

Electromechanical Cylinder EMC-125-HD-1

Ordering data	Option	Description
Short product name	EMC-125-HD-1	
Max. travel	580	580 mm
Guideway	11	Without round flange
Drive unit	02	Planetary screw assembly 48 x 10
Lubrication	01	With initial greasing
Version	MF	With motor mount
Motor attachment	03	Motor mount and coupling for MSK 101D
Motor	118	MSK 101D, without brake
Switches	02	Two limit switches
Surface finish	01	Standard
Documentation	01	Frictional torque
Mounting elements	21	Clevis bracket
	12	Spherical rod end bearing CGKD
	00	Without
	02	Trunnion mount
	00	Without
	01	Trunnion bearing block CLTB

Inquiry or Order

To be completed by customer	Option
Inquiry	
Order	

Bosch Rexroth AG
 97419 Schweinfurt
 Germany

Ordering data	Option
Short product name	E M C - - - - - H D - 1
Max. travel (mm) =	
Guideway =	
Drive unit =	
Lubrication =	
Version =	
Motor attachment =	
Motor =	
Switches =	
Surface finish =	
Documentation =	
Mounting elements =	Group 1
=	Group 2
=	Group 3
=	Group 4
=	Group 5
=	Group 6

Find your local contact person here:
www.boschrexroth.com/contact

Order quantity	Quantity
One-off	
Monthly	
Annually	
Per order	
Comments	

Sender	
Company	
Address	
Name	
Department	
Fax	
E-mail	

Glossary (definitions)

Dynamic load rating C:

Constant that is used to calculate the service life of a screw drive. The value for the dynamic load rating C represents the load under which 90% of a sufficiently large number of identical screw drives can achieve a service life of one million revolutions.

Limit switch:

Limit switches are used to monitor the end position of moving parts. They emit a signal when the component reaches a certain position, usually the beginning or end of a stroke. The signal can be electrical, pneumatic or mechanical. Typical forms of limit switches with electrical signals are roller lever switches or non-contacting switches such as photoelectric sensors and proximity switches.

Service life:

The nominal life is expressed by the number of revolutions (or number of operating hours at constant rotary speed) that will be attained or exceeded by 90% of a sufficiently large number of identical screw drives before the first signs of material fatigue become evident.

Maximum force F_{\max} :

Maximum permissible mechanical load in axial direction.

Positioning accuracy:

The positioning accuracy is the maximum deviation between the actual position and the target position, as defined in VDI/DGQ 3441.

Reference switch:

Reference switches are used to detect the position of a moved component, e.g. screw drive nut in the cylinder. The switch emits a signal when the component reaches a defined position (reference mark). Reference switches are required for incremental measuring systems or motors with incremental encoders during start-up and after any interruption to the power supply.

Lead:

Relating to screws or threaded shafts, the lead is the linear distance traveled per revolution of the screw or shaft. In the case of a single thread (single-start screws), this is the distance between two thread crests or two grooves (running tracks).

Gear ratio:

This relates to the transmission and conversion of movements, linear and rotary speeds, forces and torques in a geared mechanism. The gear ratio (also known as reduction ratio) is the ratio between the drive variable and the output variable, e.g. the ratio of input speed to output speed.

Repeatability:

The repeatability indicates how precisely a linear system positions itself when approaching a position repeatedly from the same direction (unidirectional motion). It is stated as the deviation between the actual position and the target position.

Bosch Rexroth AG

Ernst-Sachs-Straße 100
97424 Schweinfurt, Germany
Tel. +49 9721 937-0
Fax +49 9721 937-275
www.boschrexroth.com

Find your local contact person here:

www.boschrexroth.com/contact

The data specified above only serve to describe the product. As our products are constantly being further developed, no statements concerning a certain condition or suitability for a certain application can be derived from our information. The information given does not release the user from the obligation of own judgment and verification. It must be remembered that our products are subject to a natural process of wear and aging.