

eLINE Compact Modules

eCKK / eCKR

The Drive & Control Company



Linear Motion and Assembly Technologies

Ball Rail Systems
Roller Rail Systems
Linear Bushings and Shafts

Ball Screw Drives
Linear Motion Systems

Basic Mechanical Elements
Manual Production Systems
Transfer Systems

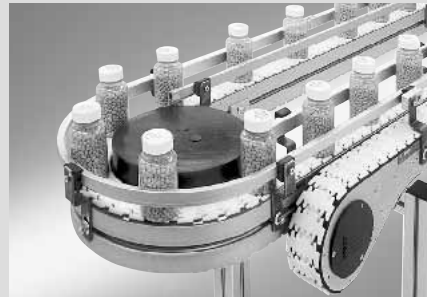
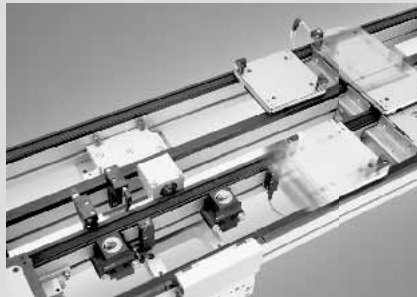
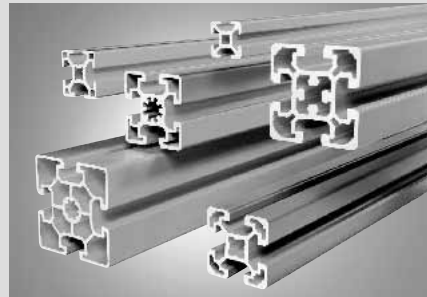
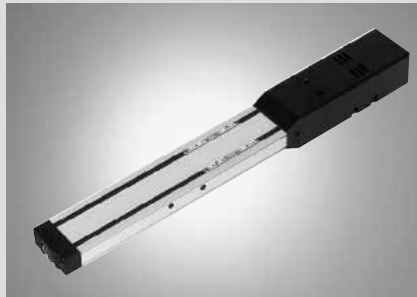
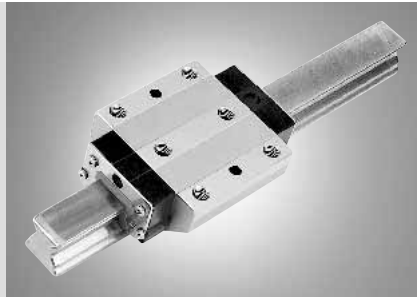
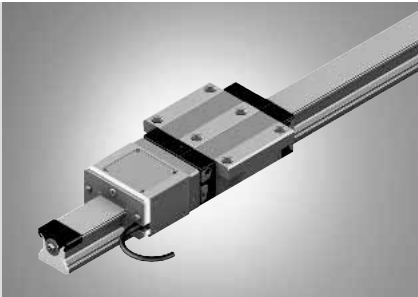

Product Overview	4
eLINE Compact Modules, eCKK	6
Technical Data	6
Performance Charts	7
Dimensions	8
Ordering Data	9
eLINE Compact Modules, eCKR	10
Technical Data	10
Performance Charts	11
Dimensions	12
Ordering Data	13
Accessories	14
Clamping Fixtures	14
Sensor Mounting	15
Cable Set	16
RS485 / USB Adapter	16
Connection Plate	16
Maintenance	17
Start-up	18
Requirements	18
Electrical Connections	18
Parameterization of Motion Tasks	19

eLINE Compact Modules

Product Overview

eLINE Compact Modules are economical, ready-to-install linear motion systems characterized by their compact design, good price/performance ratio and fast delivery.

The benefits:

- Pre-installed stepper motor with power output section and positioning control
- Can also be used without higher-level PLC (stand-alone). Automatic sequential position block processing
- Identical frame and connection dimensions as the standard Compact Module series
- Ready-made parameter files make start-up very easy (downloads available on website “www.boschrexroth.com/eline_compactmodule”)
- Easy to control by selecting motion tasks via digital inputs, or jog mode
- Manual movement (jog-mode) via digital inputs
- “Teach” function makes it easy to enter target positions
- Two integrated zero-clearance eLINE ball rail systems provide optimized travel performance
- High travel speed with high precision and smooth operation over long lengths
- With reference switch, switch activation without switching cam
- Lubricated for life

eLINE Compact Modules eCKK

- with integrated positioning drive
- with ball screw drive

eLINE Compact Modules eCKR

- with integrated positioning drive
- with toothed belt drive

Parameter set

- Available as download from Bosch Rexroth website
- Matching set for each axis version

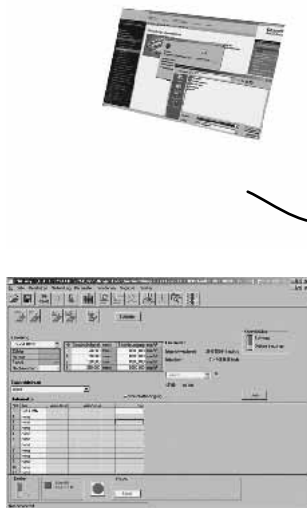

RS485/USB Adapter
 – NUDAM ND 6530
 (available as accessory)

**Customer-built
 Control of digital I/Os**

- Via buttons or with switches
- Or via a higher-level control system

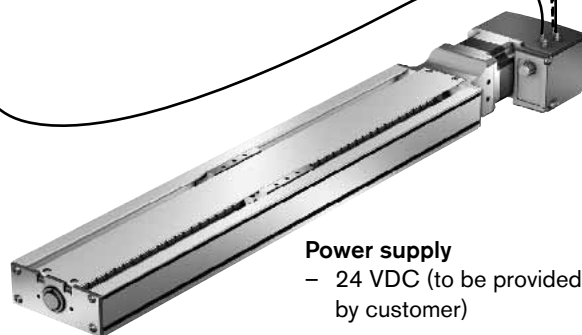
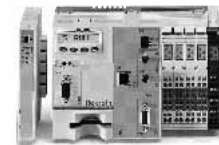

Power supply
 – 24 VDC (to be provided by customer)

Operating software

- For simple programming of integrated positioning control
- For program administration
- Communication through USB interface
- Also available as a website download

eLINE Compact Modules eCKK with ball rail systems and ball screw drive

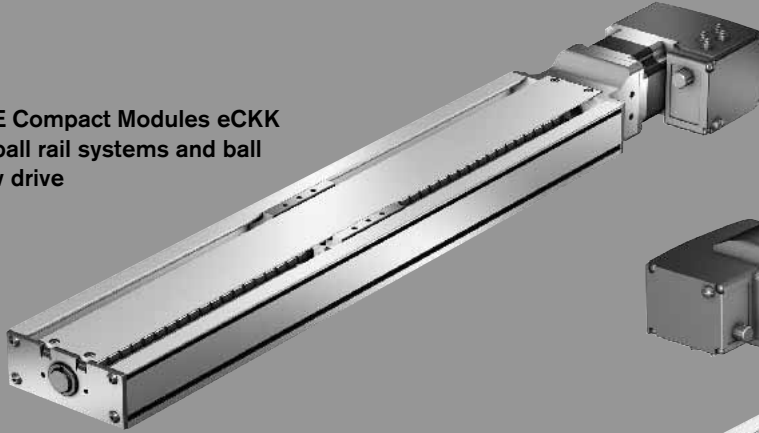

eLINE Compact Modules eCKR with ball rail system and toothed belt drive. Motor attachment on either side

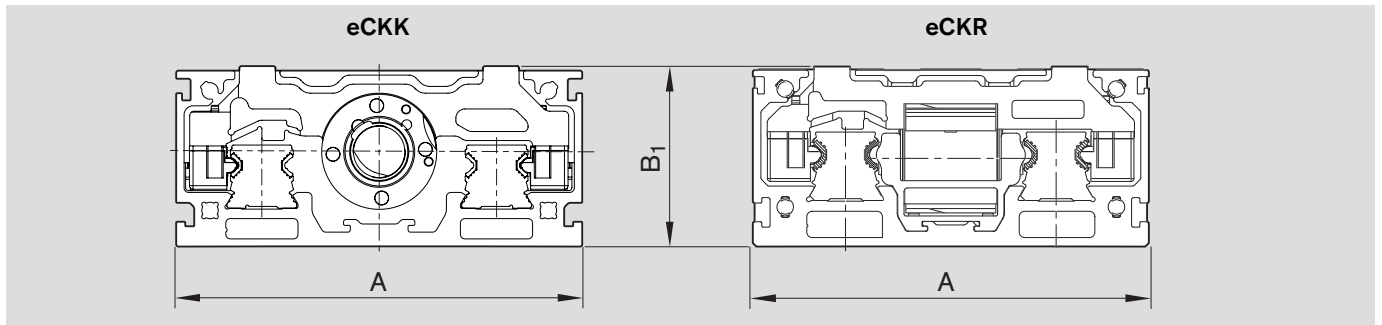
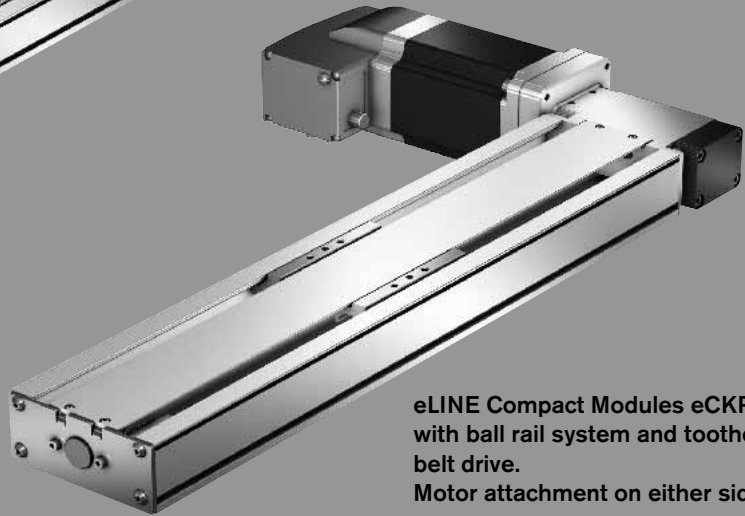

The frame size indicates the width of frame.

Size	Frame size (mm)	
	A	B ₁
eCKK / eCKR 90	90	40
eCKK / eCKR 110	110	50

eLINE Compact Modules

eLINE Compact Modules, eCKK

- All mechanical and electronic components from a single source
- Stepper motor with up to 16 parameterizable motion tasks
- Start-up requires minimal effort
- Wide variety of lengths and strokes available
- With ball screw drive



Technical Data

Size	Ball screw (mm) $d_o \times P$	Dynamic load capacity C (N)			Dynamic moments (Nm)		Planar moment of inertia (cm ⁴)		Total weight (kg)	
		Guideway	Ball screw	Fixed bearing	M_t	M_L	I_x	I_y	without brake	with brake
eCKK 90	12 x 10	5000	1500	2550	166	29	21	97	$L \cdot 0.00408 + 2.34$	$L \cdot 0.00408 + 3.34$
eCKK 110	16 x 10	11000	5800	3000	420	89	31	238	$L \cdot 0.00674 + 4.01$	$L \cdot 0.00674 + 5.86$

Elasticity modulus $E = 70,000 \text{ N/mm}^2$

Size	Max. travel speed v (m/s)	Max. acceleration a (m/s ²)	Max. permissible axial force (N)	Maximum payload (kg)	Repeatability (mm)
eCKK 90	0.60	2.3	200	15	± 0.05
eCKK 110	0.35	1.0	400	30	± 0.05

Maximum permissible loads

Size	Maximum permissible forces (N)			Maximum permissible moments (Nm)	
	F_{z1max}	F_{z2max}	F_{ymax}	M_{tmax}	M_{Lmax}
eCKK 90	250	250	250	16.6	2.9
eCKK 110	550	550	550	42.0	8.9

Dynamic characteristics for loads and moments.

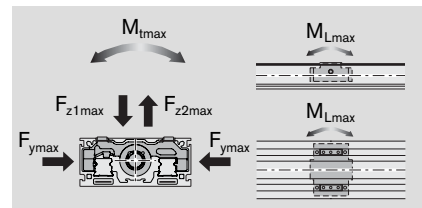
**Note on dynamic load capacities and moments (see table)**

Determination of the dynamic load capacities and moments is based on a travel life of 100,000 m. Often only 50,000 m are actually stipulated. For comparison: Multiply values C , M_t and M_L from the table by 1.26.

Performance Charts

Values apply to moved carriage only

Positioning time as a function of travel distance and length

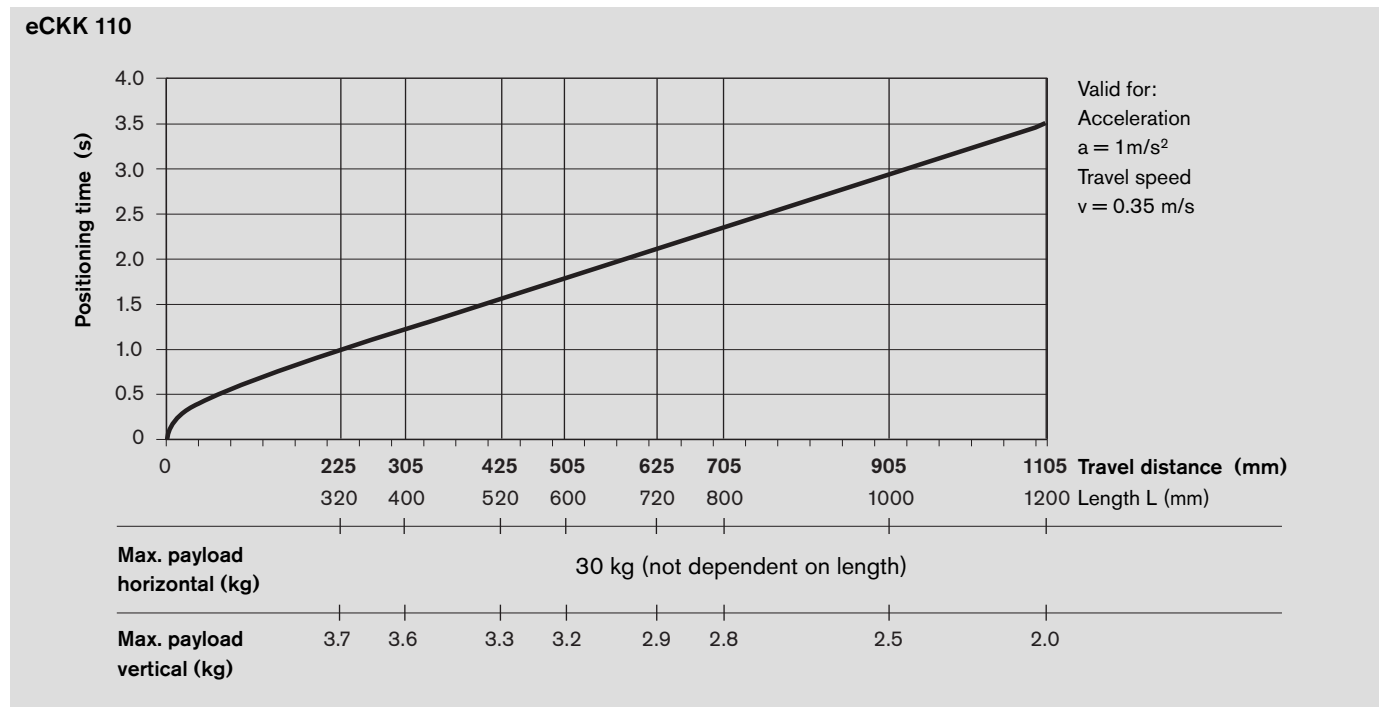
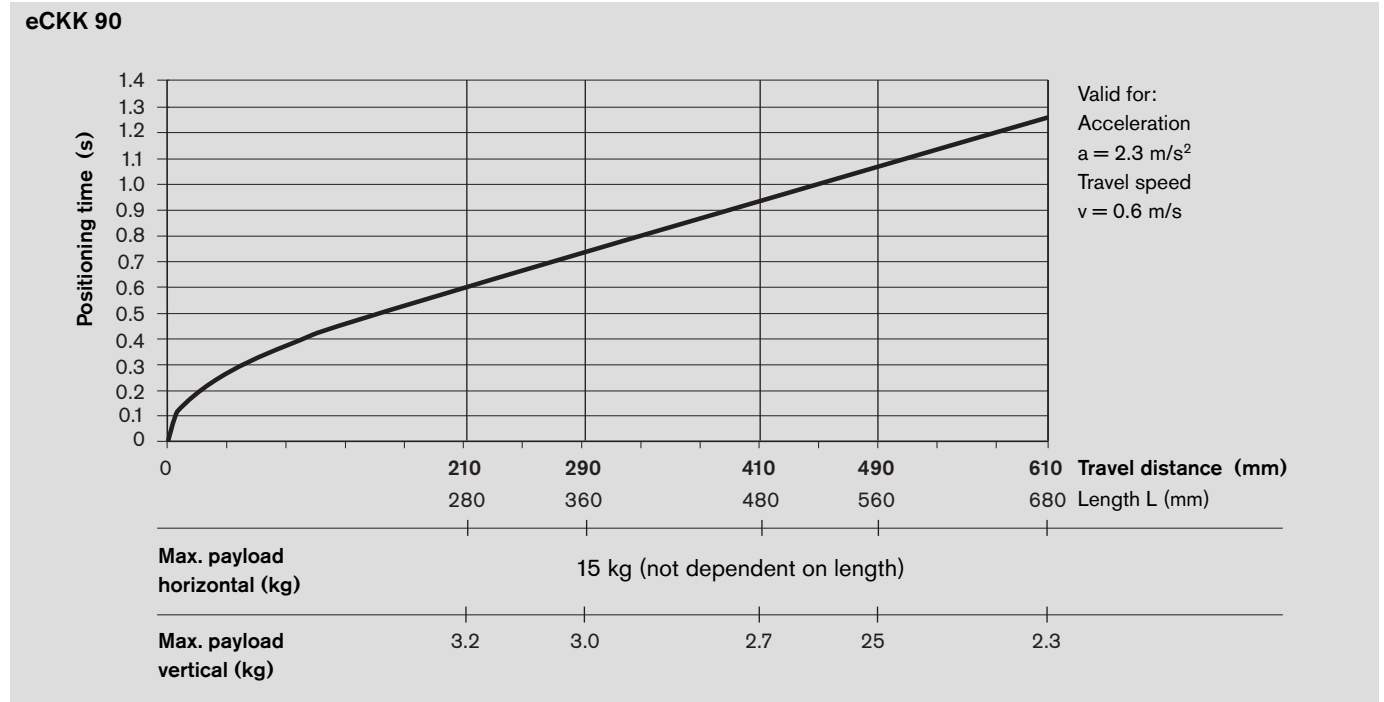

Ordering Data

eCKK 90

Length L (mm)	Maximum travel (mm)	Version	Part number
280	210	without brake	R0361 360 14
		with brake	R0361 360 15
360	290	without brake	R0361 360 18
		with brake	R0361 360 19
480	410	without brake	R0361 360 24
		with brake	R0361 360 25
560	490	without brake	R0361 360 28
		with brake	R0361 360 29
680	610	without brake	R0361 360 34
		with brake	R0361 360 35

eCKK 110

Length L (mm)	Maximum travel (mm)	Version	Part number
320	225	without brake	R0361 460 16
		with brake	R0361 460 17
400	305	without brake	R0361 460 20
		with brake	R0361 460 21
520	425	without brake	R0361 460 26
		with brake	R0361 460 27
600	505	without brake	R0361 460 30
		with brake	R0361 460 31
720	625	without brake	R0361 460 36
		with brake	R0361 460 37
800	705	without brake	R0361 460 40
		with brake	R0361 460 41
1000	905	without brake	R0361 460 50
		with brake	R0361 460 51
1200	1105	without brake	R0361 460 60
		with brake	R0361 460 61

eLINE Compact Modules

eLINE Compact Modules, eCKR

- All mechanical and electronic components from a single source
- Stepper motor with up to 16 parameterizable motion tasks
- Start-up requires minimal effort
- Wide variety of lengths and strokes available
- With toothed belt 25HTD3



Technical Data

Size	Dynamic load capacity C (N)	Dynamic moments (Nm)		Planar moment of inertia (cm ⁴)		Total weight (kg)	
		M _t	M _L	I _x	I _y	without brake	with brake
eCKR 90	5000	166	29	21	97	L · 0.003462 + 3.74	L · 0.003462 + 5.54
eCKR 110	11000	420	89	31	238	L · 0.005628 + 6.42	L · 0.005628 + 8.22

Elasticity modulus E = 70,000 N/mm²

Size	Max. travel speed v (m/s)	Max. acceleration a (m/s ²)	Maximum payload (kg)	Repeatability (mm)	
eCKR 90	1.76	2	5	± 0.2	
eCKR 110	0.75	4	15	± 0.2	

Size	Maximum permissible forces (N)			Maximum permissible moments (Nm)	
	F _{z1max}	F _{z2max}	F _{ymax}	M _{tmax}	M _{Lmax}
eCKR 90	250	250	250	16.6	2.9
eCKR 110	550	550	550	42.0	8.9

Maximum permissible loads

Dynamic characteristics for loads and moments.

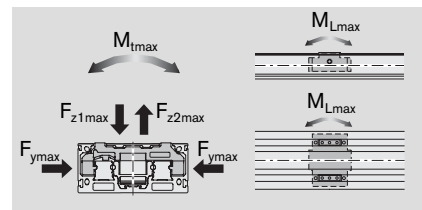

Note on dynamic load capacities and moments (see table)

Determination of the dynamic load capacities and moments is based on a travel life of 100,000 m. Often only 50,000 m are actually stipulated. For comparison: Multiply values **C**, **M_t** and **M_L** from the table by 1.26.

Performance Charts

Values apply to moved carriage only

Positioning time as a function of travel distance and length

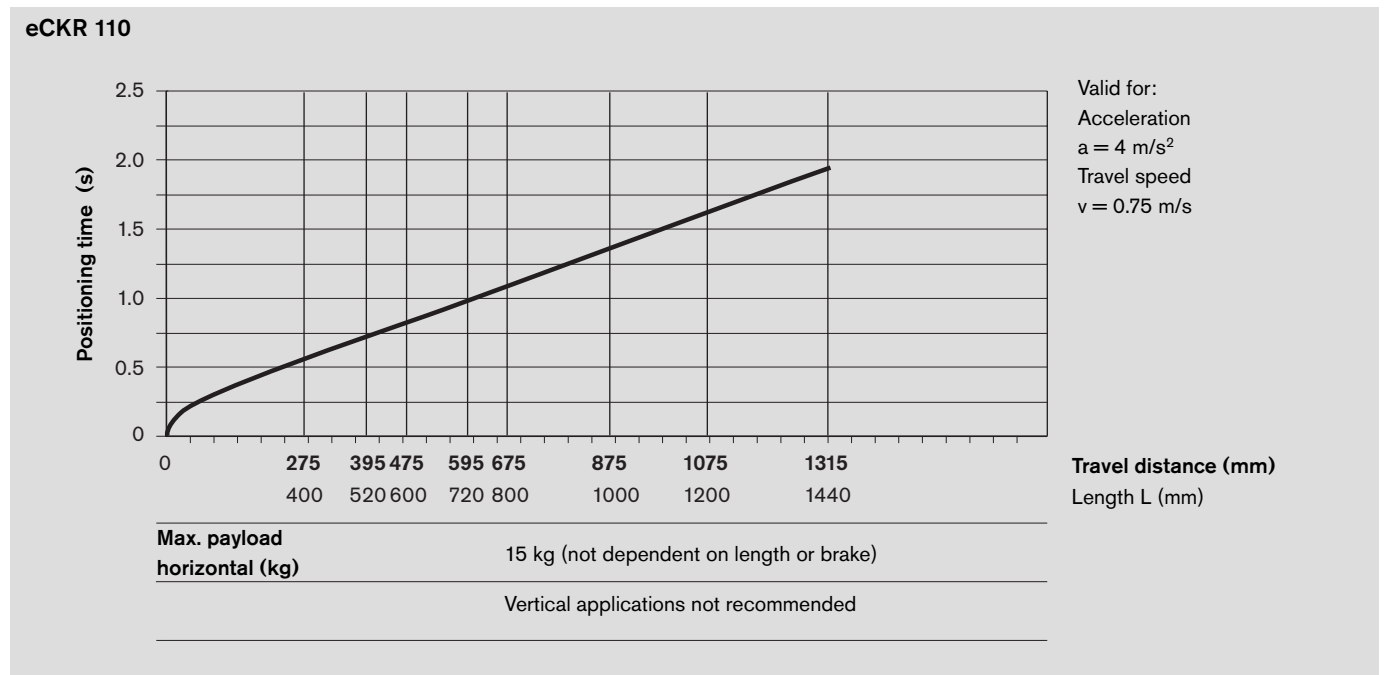
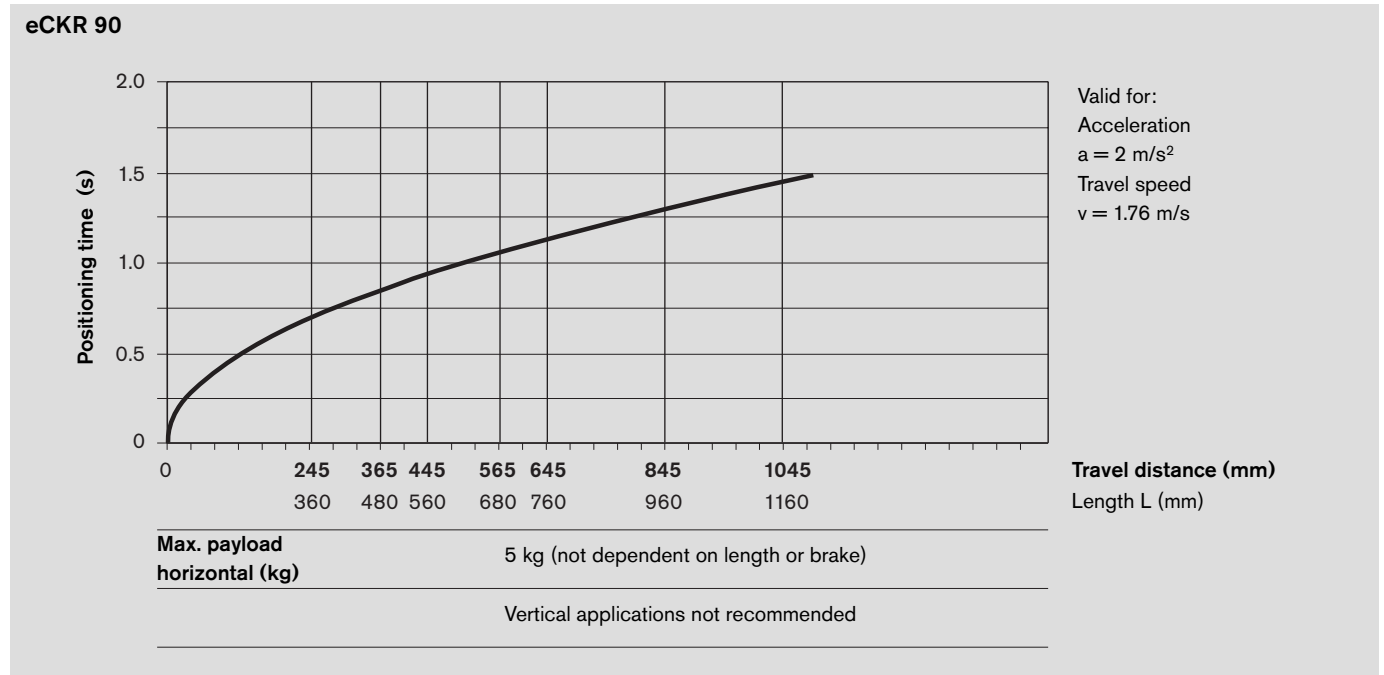

eLINE Compact Modules

eLINE Compact Modules, eCKR

Dimensions

Diagrams to different scales

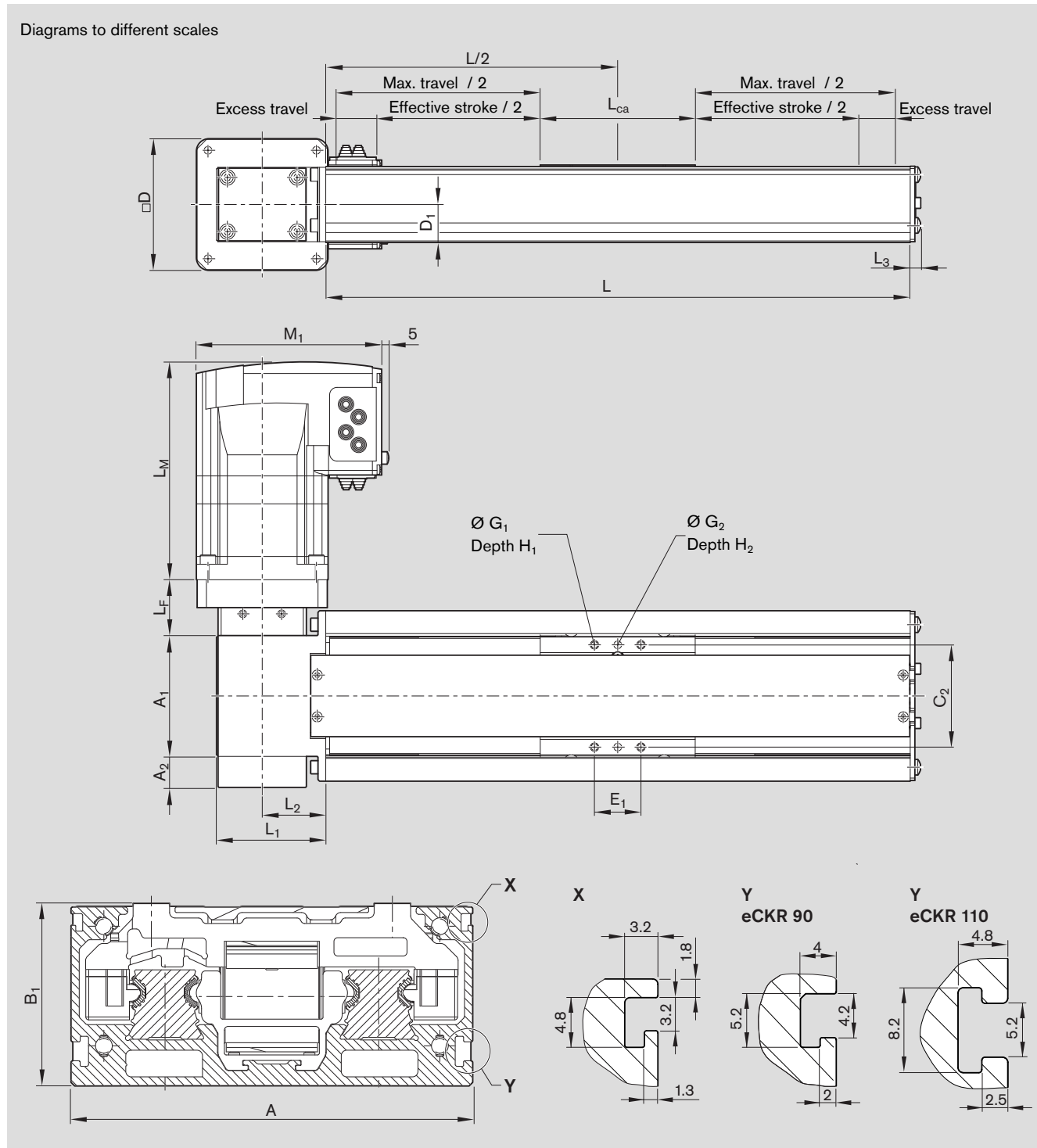

Size	Dimensions (mm)																			
	A ¹⁾	A ₁	A ₂	B ₁	C ₂ ±0.1	D ₁	□D	E ₁ ±0.1	ØG ₁	ØG ₂ H7	H ₁	H ₂	L ₁	L ₂	L ₃	L _{ca}	L _F	L _M	L _M ²⁾	M ₁
eCKR 90	90	60	16	40	54	19.5	85	27	M4	4	7	6	65.0	37	6	90	34.5	141	188	120
eCKR 110	110	78	21	50	66	24.5	85	30	M5	5	8	7	70.5	41	7	100	36.0	201	248	120

1) Frame size 2) with brake

Ordering Data

eCKR 90

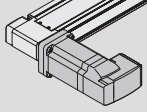
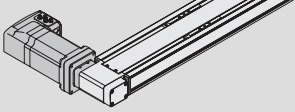
Length L (mm)	Maximum travel (mm)	Version	Part number Motor attachment right MA10 	Part number Motor attachment left MA11 
360	245	without brake	R0363 360 18	R0363 362 18
		with brake	R0363 360 19	R0363 362 19
480	365	without brake	R0363 360 24	R0363 362 24
		with brake	R0363 360 25	R0363 362 25
560	445	without brake	R0363 360 28	R0363 362 28
		with brake	R0363 360 29	R0363 362 29
680	565	without brake	R0363 360 34	R0363 362 34
		with brake	R0363 360 35	R0363 362 35
760	645	without brake	R0363 360 38	R0363 362 38
		with brake	R0363 360 39	R0363 362 39
960	845	without brake	R0363 360 48	R0363 362 48
		with brake	R0363 360 49	R0363 362 49
1160	1045	without brake	R0363 360 58	R0363 362 58
		with brake	R0363 360 59	R0363 362 59

eCKR 110

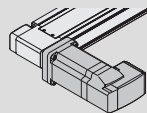
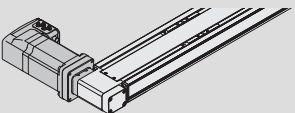
Length L (mm)	Maximum travel (mm)	Version	Part number Motor attachment right MA10 	Part number Motor attachment left MA11 
400	275	without brake	R0363 460 20	R0363 462 20
		with brake	R0363 460 21	R0363 462 21
520	395	without brake	R0363 460 26	R0363 462 26
		with brake	R0363 460 27	R0363 462 27
600	475	without brake	R0363 460 30	R0363 462 30
		with brake	R0363 460 31	R0363 462 31
720	595	without brake	R0363 460 36	R0363 462 36
		with brake	R0363 460 37	R0363 462 37
800	675	ohne Bremse	R0363 460 40	R0363 462 40
		with brake	R0363 460 41	R0363 462 41
1000	875	without brake	R0363 460 50	R0363 462 50
		with brake	R0363 460 51	R0363 462 51
1200	1075	without brake	R0363 460 60	R0363 462 60
		with brake	R0363 460 61	R0363 462 61
1440	1315	without brake	R0363 460 72	R0363 462 72
		with brake	R0363 460 73	R0363 462 73

Accessories

Clamping Fixtures

General notes:

Compact Modules are mounted to the customer-built mounting base using clamping fixtures.

⚠ Do not secure or support the eLINE Compact Module at the end enclosures or end blocks! The frame is the load-bearing part!

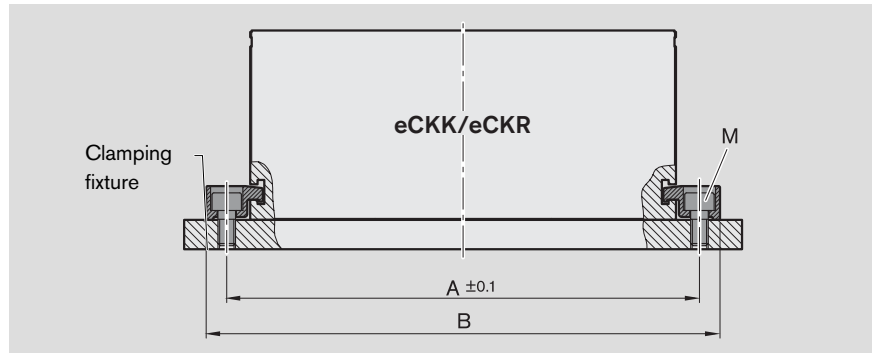

Frame size	A (mm)	B (mm)	M
90	102	112	M4
110	126	140	M5, M6

Recommended number of clamping fixtures:

- Type 1: 6 pieces per meter and side
- Type 2: 4 pieces per meter and side
- Type 3: 3 pieces per meter and side

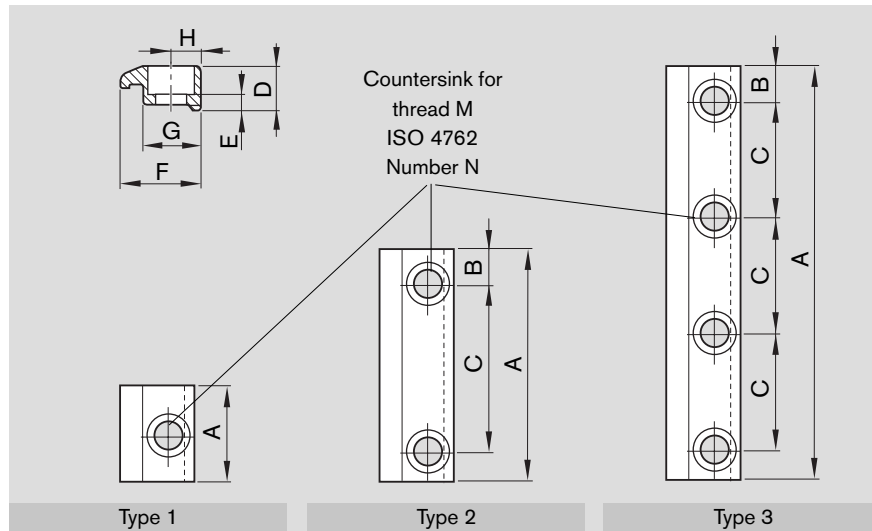

Frame size	For thread	Type	Number of holes N	Dimensions (mm)							Part number	
				A	B	C	D	E	F	G		H
90	M4	1	1	25	-	-	9	4.6	14.5	10.5	5	R0375 310 00
		3	4	87	6	25		4.6				R0375 310 02
		3	4	107	8.5	30		4.6				R0375 310 03
		2	2	72	11	50		3.2				R0375 310 13
		2	2	62	11	40		3.2				R0375 310 15
		3	4	77	8.5	20		4.6				R0375 310 26
		110	M5	3	4	107		8.5				30
3	4			77	20	4.8	R0375 410 26					
1	1			25	-	-	5.3	R0375 510 00				
M6	3		4	142	11	40	11.5	5.3	19.3	14	7	R0375 510 02
	2		2	72	11	50		3.2				R0375 510 09
	2		2	62	11	40		3.2				R0375 510 11
	2		2	47	8.5	30		5.3				R0375 510 23

Sensor Mounting

⚠ One switch is needed as a reference switch when starting up the axis.

With magnetic field sensors, switch activation is direct (without switching cam). Sensors may be mounted only on one side of the eLINE Compact Modules (left or right) and only after installing the module to the mounting base.

The switches are slid into the upper T-slot on the sensor mount and secured with set screws. The square nut serves as a stop for the sensor, so it is not necessary to re-adjust the position when replacing a sensor.

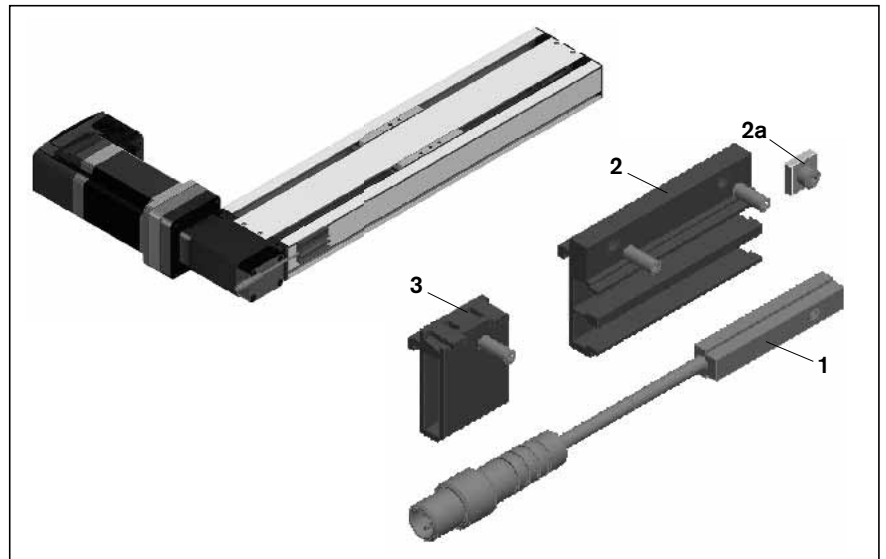

Sensor mounting kit

Consisting of:

- 1 Hall sensor
- 2 Sensor mount (material: plastic) incl. set screw (loose) and square nut 2a
- 3 Cable holder (3 units, material: plastic) incl. set screw (loose)

Type	Part number
Sensor mounting kit with Hall sensor	R0375 300 08

Sensor configuration:

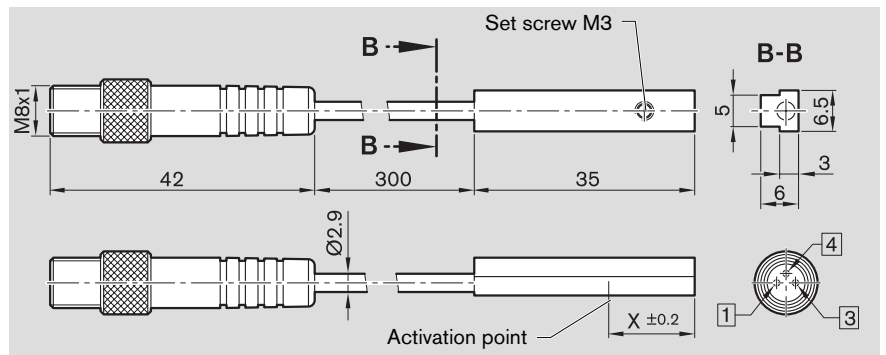

Part number	Hall sensor R3476 024 03
Dimension X	13.65 mm
Contact type	PNP - NC
Operating voltage	3.8 - 30 VDC
Power consumption	max. 10 mA
Output current	max. 20 mA
Housing protection class	IP 66
Short-circuit protection	No
Perm. travel speed	2 m/s
Housing material	Ultramid

Pin assignment

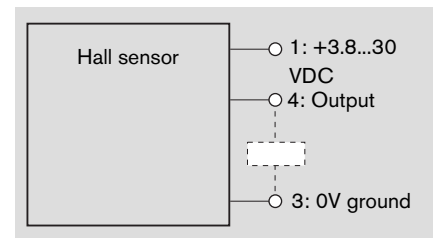

- Hall sensor (PNP - NC)

Accessories

Cable Set

The cable set consists of the cable (black sheath) for the 24V power supply; the signal cable (gray sheath) for digital inputs and outputs; and the RS485 interface. The cable set is 5 m long.



Part number: R1130 695 74

The plugs are inserted through the side openings in the terminal box and engaged in the plug sockets.

See "Start-up" section for connection diagram.

Detailed description available in product manual IclA IDS MIO or at www.boschrexroth.com/eline_compactmodule

RS485 / USB Adapter

An adapter is required to connect the motor (RS485) to the PC (USB).

Part number: R1130 896 77

A 1-meter USB connection cable and the driver software are included with delivery.



Connection Plate

Connection plates are fixed to the carriage with four screws and two pins.

Size	Part number
eCKx 90	R0375 300 25
eCKx 110	R0375 400 25

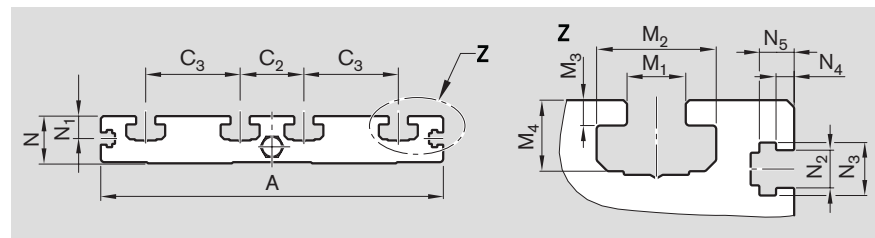
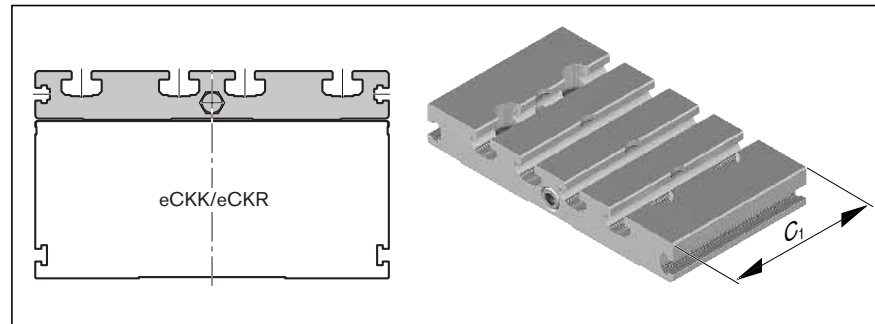

Size	Dimensions (mm)														
	A ¹⁾	C ₁	C ₂	C ₃	N	N ₁	N ₂	N ₃	N ₄	N ₅	M ₁	M ₂	M ₃	M ₄	
eCKx 90	90	60	20	20	17	7.6	4.2	7.3	2	4.3	6	12	3.5	7.7	
eCKx 110	110	60	20	20	17	9.5	5.2	7.3	2.5	4.8	6	12	3.5	7.7	

1) Frame size

Maintenance

Long-term maintenance-free operation is achievable due to the pre-lubricated eLINE Ball Rail Systems and the pre-lubricated Ball Screw .

Initial lubrication is done in-factory prior to shipment. The service life of the initial lubrication applies to normal operating conditions.

Normal operating conditions

Ambient temperature: 10 °C ... 40 °C
 Load: < 5% C
 Travel speed: < 1 m/s

For special operating conditions - e.g. special installation type, short stroke, or the presence of dust or solvents - the lubrication intervals must be adapted to the specific application.

Service life of initial lubrication

	Service life (km)
Guideway	4000
Ball screw	1000

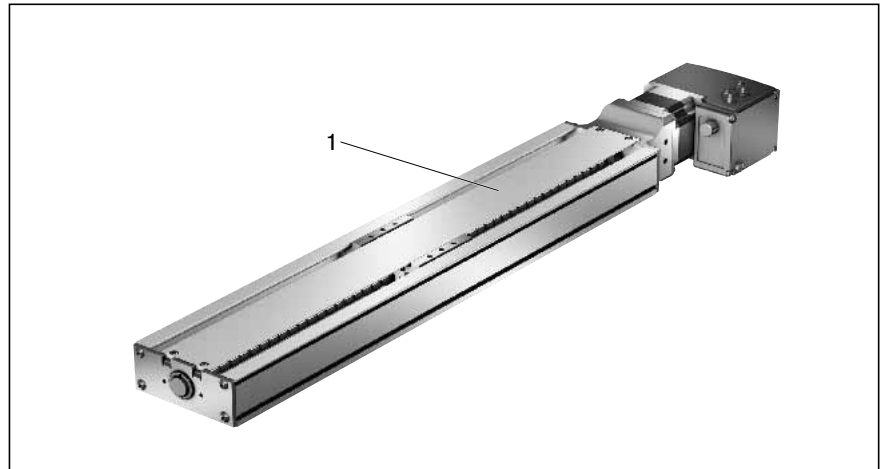

The ball-screw and ball-rail systems can be relubricated in order to extend their service life.

- Remove cover plate (1)
- Using a brush, apply a light film of grease (NLGI2) to the ball-screw and to the running tracks on the sides of the guide rails.
- Move the carriage along the entire travel range several times
- Use a cloth to remove the excess grease at the end positions.
- Fasten cover plate (1)

Grease: Lithium soap grease KP2K (DIN 51825) with consistency class NLGI 2 (DIN 51818)

⚠ Do not use greases with solid lubricant components (such as graphite and MoS₂ additives)!

Start-up

Intelligent compact drive with Motion Sequence Mode and IclA IDS-MIO stepper motor.

For detailed documentation see the "IclA IDS-MIO" product manual or at "www.boschrexroth.com/eline_compactmodule"

Requirements

Delivered hardware:

- Linear axis with integrated motor (IclA Easy IDS-MIO with firmware version V00.016 or higher)
- Pre-assembled cable set (*must* be ordered separately)
- Reference switch (*must* be ordered separately)
- RS485 / USB adapter NUDAM ND 6530 (*must* be ordered separately)

Customer supply:

- 24 V DC power source, at least 10 A (for optimal utilization of available torques)
- Windows PC with USB interface, WIN95 or higher operating system

Software:

- Installed IclA Easy Easy-Terminal software or BLCT Suite (current version available at "www.boschrexroth.com/eline_compactmodule") on PC, operating system WIN95 or higher
- Parameter files with axis-specific defaults for eCKK 90, eCKK 110, eCKR 90, or eCKR 110 at "www.boschrexroth.com/eline_compactmodule"

Electrical Connections

- Unscrew the cover of the motor's plug compartment.
- Connect the plugs of the pre-assembled cables to the corresponding sockets. All plugs are polarity safe and must engage when inserted.
- Always grip the plug by its housing (never pull on the cable).
- Slide the cable grommet into the recesses on the housing.

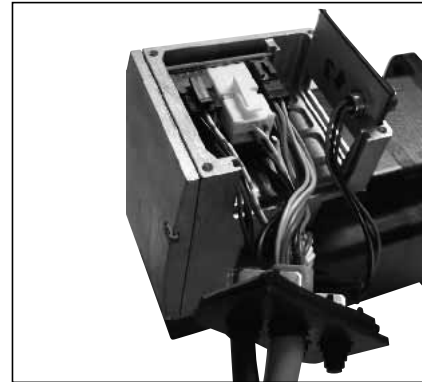

ATTENTION:

Two of the four 90-degree corners on the cable bushing are rounded. When inserting the cable bushing into the housing, the rounded corners must be inserted first, otherwise the cable bushing will not lock positively with the housing and protection class IP54 will not be achieved.

- Then screw the plug compartment cover back in place. (If originals are misplaced, use only screw size M3x12).
- Connect reference switch to the M8 socket.
- Secure the reference switch on the motor end of the axis.
- The reference switch simultaneously serves as a negative limit switch (i.e. no travel past this point when axis in operation).
- Switching position must be within the maximum travel.

Recommendation: Place switching position about 1 mm before the end of the travel range (at default reference speed).

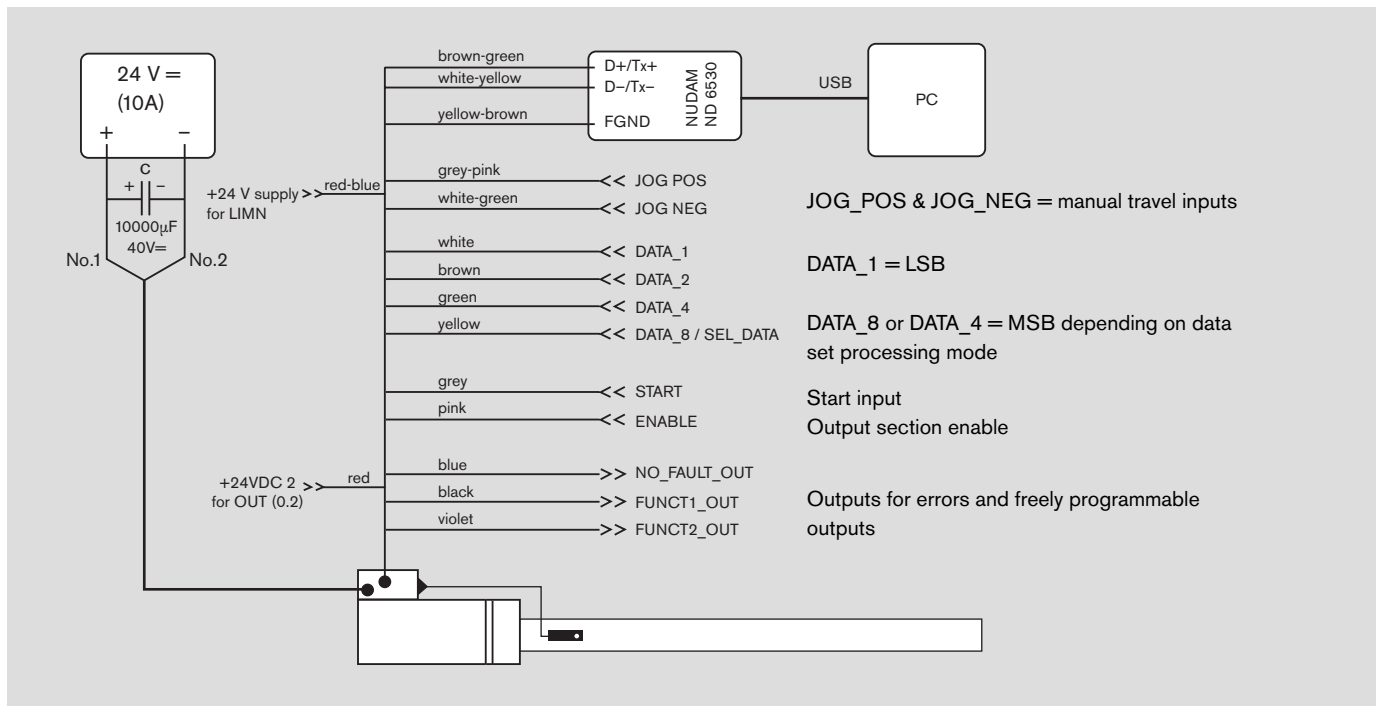

Power supply: 24 V DC
Important notes:

- Avoid reverse polarity +/- and overvoltage of the DC supply!
- Connect or disconnect DC power supply of the IclA-IDS-MIO when de-energized (power pack switched off).
- Connect electrolytic capacitor 10,000 µF 40 VDC = parallel to 24 VDC supply.

The axis can be moved manually (even without start-up tool) via the JOG inputs after the 24 V supply voltage has been switched on.

Parameterization of Motion Tasks

- Open IclA Easy
- Set the communication parameters

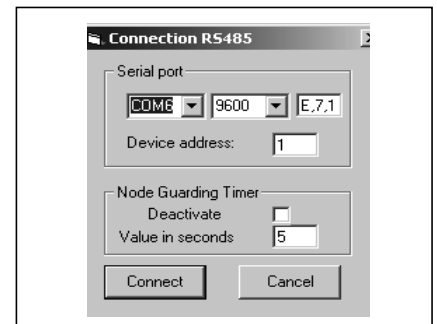

- Open window for editing data sets (by selecting menu "Functions/Motion Sequence Mode" or via the ICON

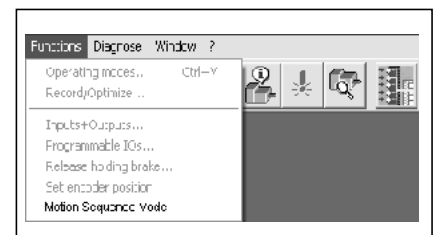

Start-up

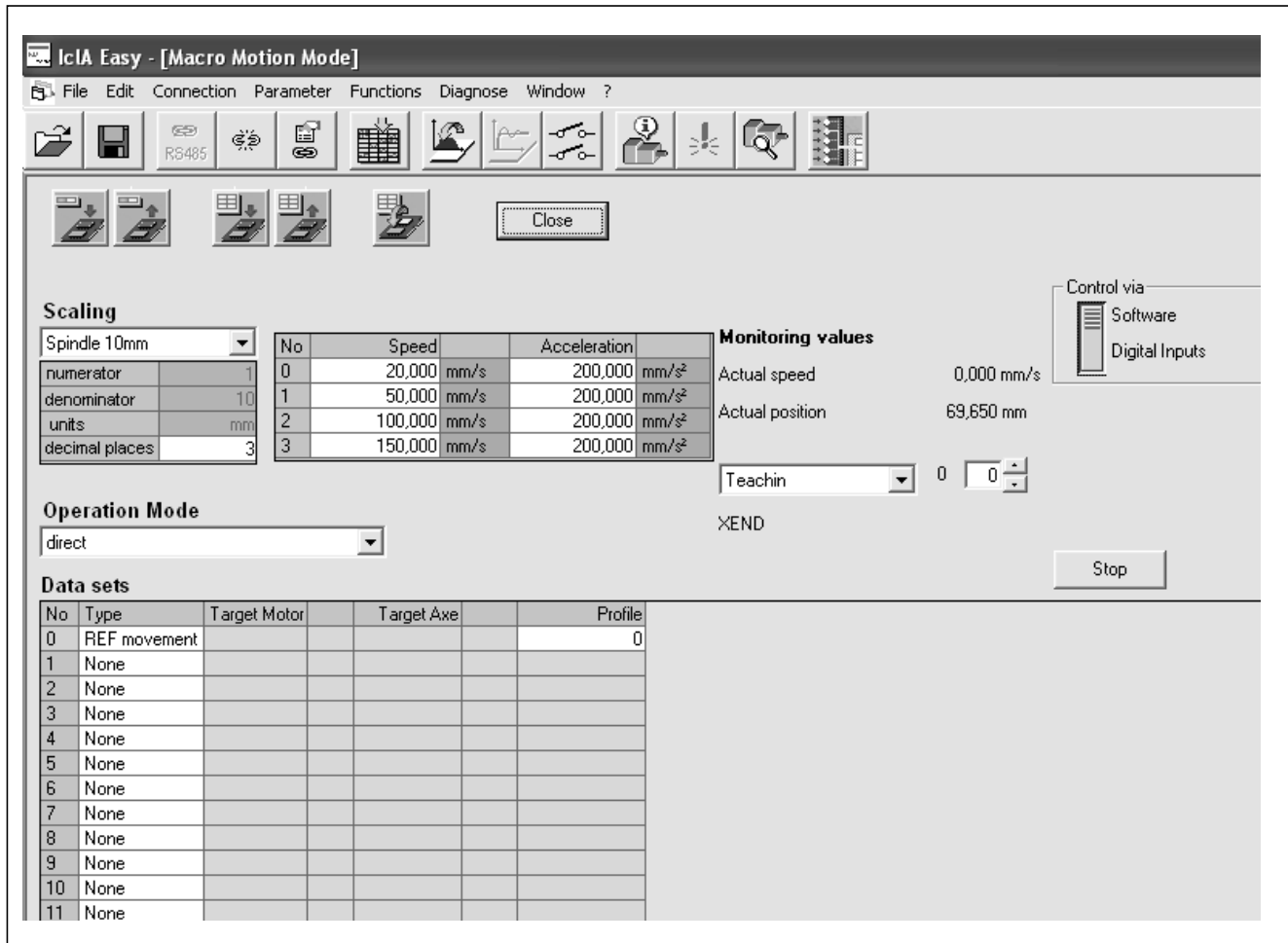

IclIA data set editing view

- Control of the drive can be switched between “Control via software tool” or “Control via digital inputs”.
- Parameterization of up to 4 different motion profiles (speed and acceleration)

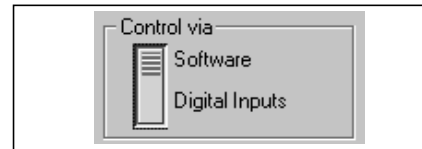

No	Speed	Acceleration
0	20,000 mm/s	200,000 mm/s ²
1	50,000 mm/s	200,000 mm/s ²
2	100,000 mm/s	200,000 mm/s ²
3	150,000 mm/s	200,000 mm/s ²

The following settings for speed and acceleration are maximum recommended values and are based on the respective selection charts in the “Performance Charts” section.

Size	Maximum recommended values	
	Speed (mm/s)	Acceleration (mm/s ²)
eCKK 90	600	2300
eCKK 110	350	1000
eCKR 90	1760	2000
eCKR 110	750	4000

- Set the scaling to match the mechanical parameters of the installed axis (mm/rev)

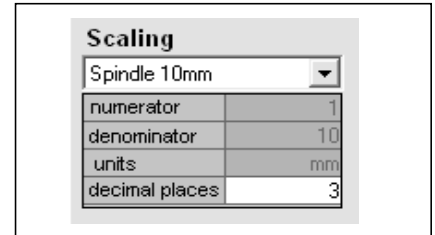

Size	Setting
eCKK 90 and eCKK 110	Screw 10 mm
eCKR 90	User defined: Counter = 1, denominator = 66
eCKR 110	User defined: Counter = 1, denominator = 90

- Two data set processing modes are possible.
 - Direct: Selection of positioning sets directly via digital inputs (DATA_x)
 - Sequential: Direct set selection plus additional functions

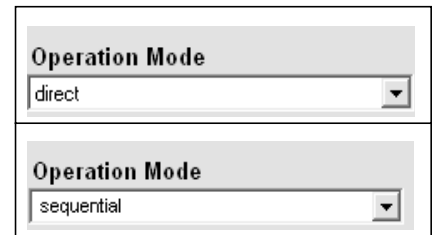

- Travel targets can be accepted into a selected travel data set via "Teach In" or approached directly in "Test mode".
- (Prior referencing required)



- Save data sets to the drive (RAM) or load them from the drive; or save module-specific data sets as resident in EEPROM.



Note

After changing parameters, we recommend saving the data as resident in the drive. Then remove and reapply the 24V supply, since changes to some parameters (like the "invertDir" parameter) will take effect only after switching back on.

Start-up

Position block processing modes

No	Type	Target Motor	Target Axis	Pulse	Condition	Next	TimeOutStart	TimeOutEnd	Pulse
0	REF movement on LIMN			1	rising edge	-	unchanged level	unchanged level	300 ms
1	Absolute positioning	2.000	inc	10.000 mm	rising edge	-	unchanged level	unchanged level	300 ms
2	Absolute positioning	1.20000	inc	510.000 mm	rising edge	0	unchanged level	unchanged level	300 ms
3	None				rising edge	0	unchanged level	unchanged level	300 ms
4	None				rising edge	0	unchanged level	unchanged level	300 ms
5	Relative positioning				falling edge	1	Level	Level	300 ms
6	HE- movement on LIMP				level	3	0-level	Level	300 ms
7	HE- movement on LIMN				level	3	inverted level	inverted level	300 ms
8	REF+ with index pulse				GlobCond	4	unchanged level	unchanged level	300 ms
9	REF+ with index pulse				auto	5	unchanged level	unchanged level	300 ms
10	REF- with index pulse				rising edge	6	unchanged level	unchanged level	300 ms
11	Set dimensions				rising edge	7	unchanged level	unchanged level	300 ms
12	None				rising edge	1	unchanged level	unchanged level	300 ms
13	None				rising edge	-	unchanged level	unchanged level	300 ms
14	None				rising edge	-	unchanged level	unchanged level	300 ms
15	None				rising edge	-	unchanged level	unchanged level	300 ms

“Direct” position block processing mode

- Travel type selectable between:
 - Absolute positioning (only possible after referencing)
 - Relative positioning
 - Homing cycle to LIMN
 - (Homing cycle to LIMP not possible)
 - Homing cycle to index pulse (1 index pulse / rev.)
 - Explicit dimension setting without travel

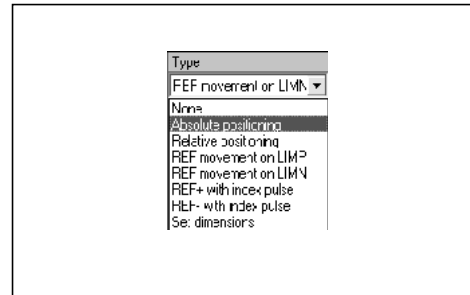

- Travel targets
 - Can be set in motor increments (20,000 inc/rev.) or in linear travel distance.
 - Automatic conversion from “Increments” to „mm“ or vice versa consistent with scaling (lead constant).

Target Motor		Target Axis	
20000	inc	10,000	mm

- Travel profile
 - Selection of a previously defined travel profile.

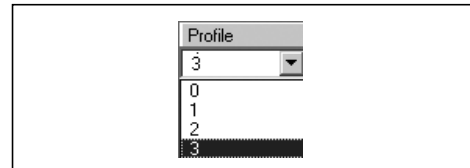

“Sequential” position block processing mode

Sequential data set selection offers more options than direct set selection

- Setting of set sequencing rules
 - Rising edge ⇒ edge change from 0 to 1 at START input
 - Falling edge ⇒ edge change from 1 to 0 at START input
 - Level 1 ⇒ static signal 1 at START input
 - Level 0 ⇒ static signal 0 at START input
 - GlobCond ⇒ Relay condition according to setting of GlobCond parameter.

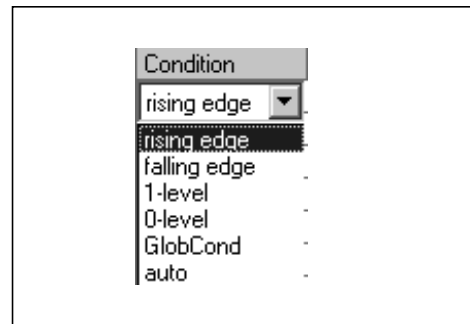

- AUTO ⇒ Automatic progression to next data set as soon as current travel data set has been worked through and pause time has elapsed.

- Selection of the next travel data set to be executed in the sequence

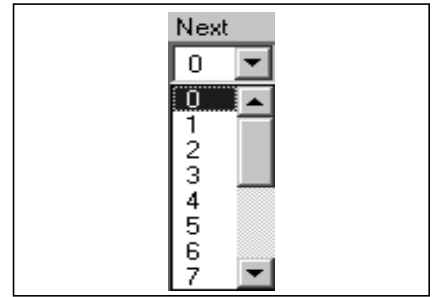

- Triggering of a digital output (FUNCT1_OUT or FUNCT2_OUT) at the start or end of a set. The output to be switched must be defined under "DataSet" (see below) as a trigger output.
 - Unchanged level → output does not change the signal condition
 - Level 1 → output is switched to High at start or end of set
 - Level 0 → output is switched to Low at start or end of set
 - Inverted level → output is inverted at start or end of set

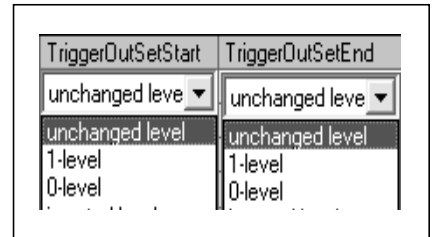

- Pause after reaching the travel target of the current travel data set.

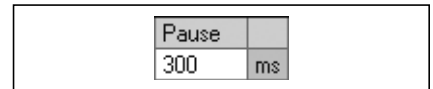

- FuncOUT_1 or FuncOUT_2 must be defined as a trigger output in order to be able to apply the signals TriggerOutSetStart and TriggerOutSetEnd to the selected output

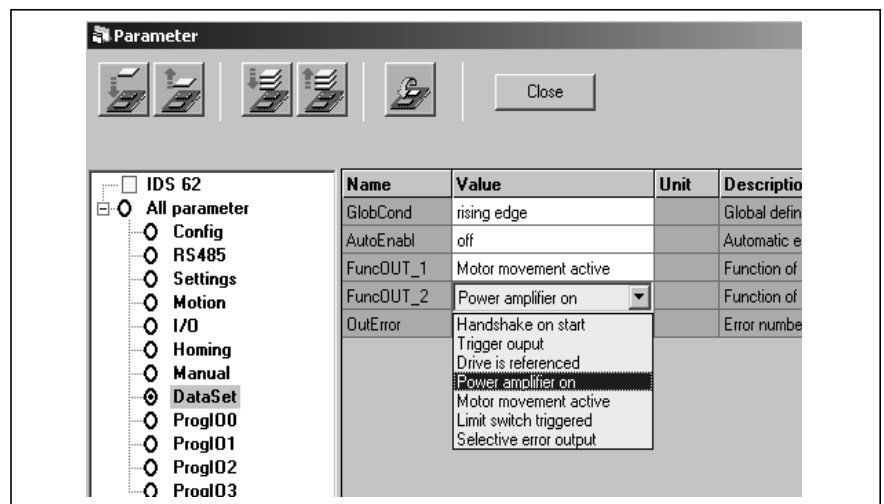

- Global relay condition
 - This parameter can be used to set the condition for relaying.

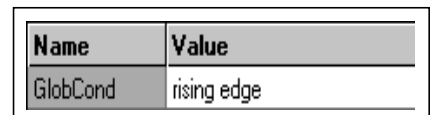

Start-up

Starting the position blocks

- Select the travel data set by sending the appropriate binary-bit pattern DATA_x
- LSB = input DATA_1,
- MSB = input DATA_8 for direct block selection
- MSB = input DATA_4 for sequential block selection

- Switch ENABLE input to high (edge change from 0 to 1 necessary)
- Start the selected position block:
- For direct block selection:
 - by edge 0 to 1 at START input
- For sequential block selection:
 - by edge 0 to 1 at START input to start of the first block to be executed in the sequence.
 - The subsequent position blocks will then be started as defined in the relay condition.

Remark:

The next set to be processed as defined in the sequential order can be changed after completion of the current position block as soon as fulfillment of the relay condition is pending:

- Select the next block via bit pattern to DATA 1, DATA 2, and DATA_4
- Accept the next block via edge 0 to 1 and SEL_DATA (= DATA_8)
- Absolute position blocks can be started only after successful execution of a homing cycle.
- Delete any appearing errors
- Apply a negative edge to ENABLE (causes loss of reference)

Important general settings

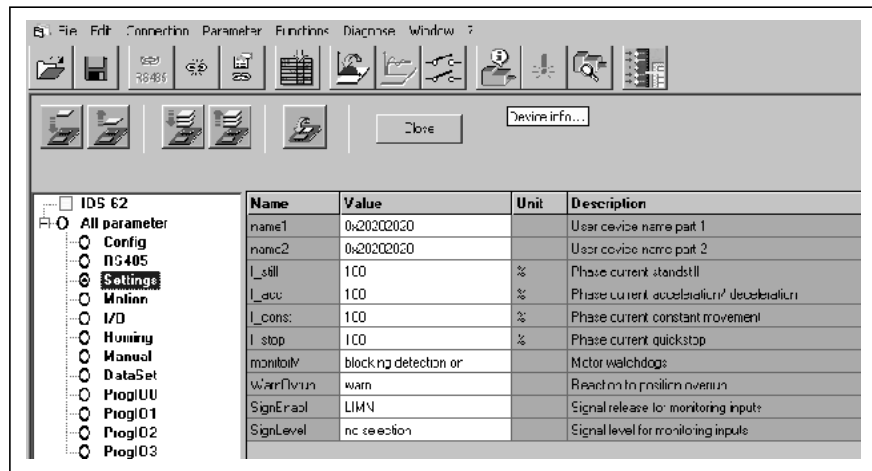

- Set motor currents to 100%.

I_still	100
I_acc	100
I_const	100
I_stop	100

- Motor stall detection "ON".
Warn if position overrun

monitorM	blocking detection on
WarnOverrun	warn

- Setting of the monitoring inputs:
 - Only LIMN permitted for signal enable
 - Signal level "none selection" (setting for NC contact at LIMN)

SignEnabl	LIMN
SignLevel	no selection

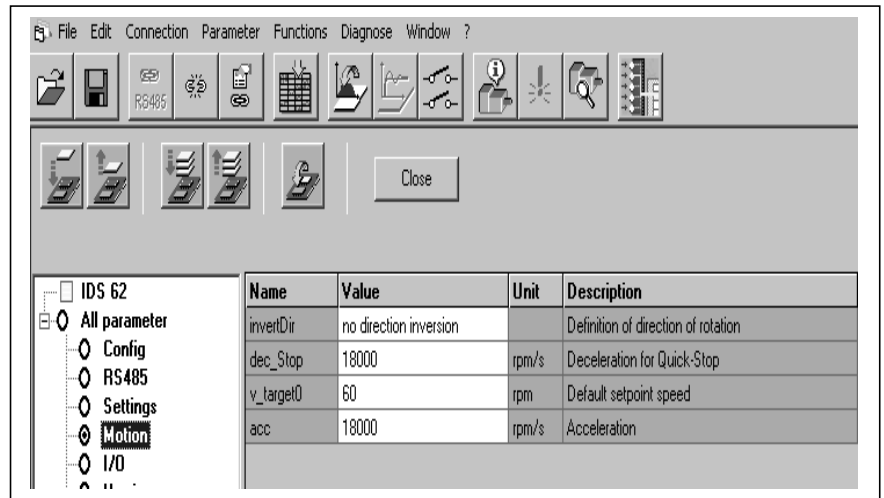

Setting the “positive” travel direction (invertDir)

There are two ways to attach the motor to the belt-driven module (eCKR):

- MA10 motor attached at right ➔ set “invertDir” to “Direction reversal active”.
- MA11 motor attached at left ➔ set “invertDir” to “No inversion of direction”.

Note: A change in the “invertDir” parameter will take effect only when:

- the parameter has been saved as resident in the drive and
- the 24V supply was switched off and then back on

Size	Motor attachment version	invertDir
eCKK 90		No inversion of direction
eCKK 110		No inversion of direction
eCKR 90	MA11	No inversion of direction
eCKR 110	MA11	No inversion of direction
eCKR 90	MA10	Direction reversal active
eCKR 110	MA10	Direction reversal active

Deceleration setting for Quick-Stop (dec_stop)

- The deceleration value for emergency stop will depend on mechanical parameters of the installed axis.
- Deceleration “dec_stop” should not be set lower than the acceleration values in the travel profiles.
- Deceleration for Quick-stop corresponds to the deceleration when the reference switch is reached.
- Recommendation: Use the same deceleration setting for “dec_Stop” as the suggested acceleration in the travel profiles.

Suggested acceleration in rpm · s

Size	Acceleration (mm/s ²)	dec_stop (rpm · s)
eCKK 90	2300	13800
eCKK 110	1000	6000
eCKR 90	2000	1818
eCKR 110	4000	2667

Acceleration setting for manual travel (acc)

Recommendation: Same setting as for “dec_stop” or for suggested accelerations in the travel profiles.

Size	Acceleration (mm/s ²)	acc (rpm · s)
eCKK 90	2300	13800
eCKK 110	1000	6000
eCKR 90	2000	1818
eCKR 110	4000	2667

Start-up

Settings for homing cycle (HOMING)

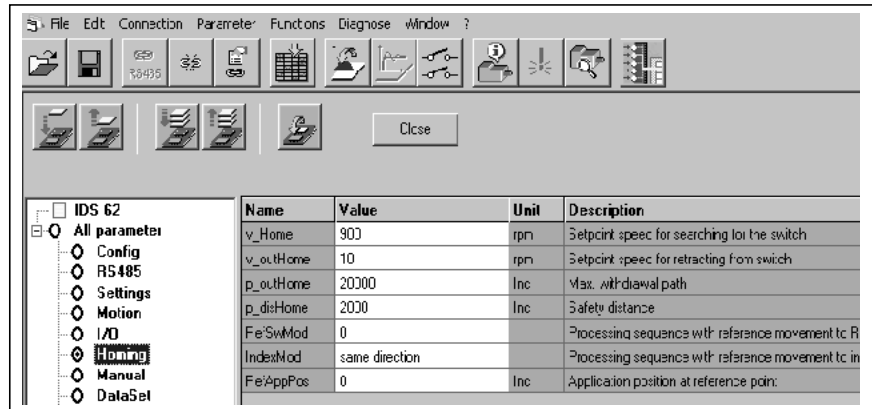

The speed for approaching the reference switch (LIMN) is not set using the parameter (v_Home) but is defined as (LIMN) in the travel profile.

Speed (v_outHome) in rpm for free travel when leaving the reference switch (LIMN)

Size	Speed (mm/s)	v_outHome (rpm)
eCKK 90	10	60
eCKK 110	10	60
eCKR 90	10	approx. 9
eCKR 110	10	approx. 7

Name	Value	Unit
v_Home	30	U/min
v_outHom	60	U/min
p_outHom	200000	Inc
p_disHom	200	Inc
RefSwMod	0	

Maximum run-off (p_outHome) in "Increments" (20,000 Inc = 1 revolution)

Size	Maximum run-off (mm)	p_outHome (Inc)
eCKK 90	20	40000
eCKK 110	20	40000
eCKR 90	20	approx. 6000
eCKR 110	20	approx. 4400

Name	Value	Unit
	4	

Safety distance (p_disHome) from the switching edge

Size	Safety distance (mm)	p_disHome (Inc)
eCKK 90	1	2000
eCKK 110	1	2000
eCKR 90	1	approx. 300
eCKR 110	1	approx. 220

Name	Value	Unit
	0	

Settings for manual movement (MANUAL)

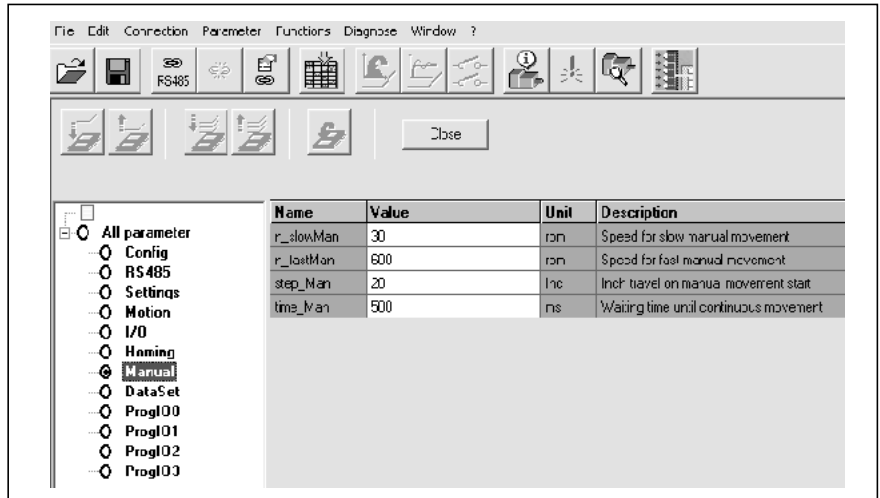

Speed for manual movement (n_slowMan)

Size	Speed (mm/s)	n_slowMan (rpm)
eCKK 90	50	300
eCKK 110	50	300
eCKR 90	50	approx. 45
eCKR 110	50	approx. 33

Name	Value	Unit
n_slowMan	30	U/min
n_fastMan	600	U/min
step_Man	20	Inc
time_Man	500	ms

Inching distance for manual start (step_Man)

Size	Inching distance (µm)	step_Man increments
eCKK 90	50	100
eCKK 110	50	100
eCKR 90	50	approx. 15
eCKR 110	50	approx. 11

Name	Value	Unit
n_slowMan	30	U/min
n_fastMan	600	U/min
step_Man	20	Inc
time_Man	500	ms

Waiting period until continuous running (time_Man)

Name	Value	Unit
n_slowMan	30	U/min
n_fastMan	600	U/min
step_Man	20	Inc
time_Man	500	ms

Detailed description of handling in product manual IclA IDS MIO or at ["www.boschrexroth.com/eline_compactmodule"](http://www.boschrexroth.com/eline_compactmodule)

Bosch Rexroth Corporation
Linear Motion and
Assembly Technologies
14001 South Lakes Drive
Charlotte, NC 28273
Telephone (800) 438-5983
Facsimile (704) 583-0523
www.boschrexroth-us.com

Bosch Rexroth Corporation
Corporate Headquarters
5150 Prairie Stone Parkway
Hoffman Estates, IL 60192-3707
Telephone (847) 645-3600
Facsimile (847) 645-6201

Bosch Rexroth Corporation
Industrial Hydraulics
2315 City Line Road
Bethlehem, PA 18017-2131
Telephone (610) 694-8300
Facsimile (610) 694-8467

Bosch Rexroth Corporation
Electric Drives and Controls
5150 Prairie Stone Parkway
Hoffman Estates, IL 60192-3707
Telephone (847) 645-3600
Facsimile (847) 645-6201

Bosch Rexroth Corporation
Pneumatics
1953 Mercer Road
Lexington, KY 40511-1021
Telephone (859) 254-8031
Facsimile (859) 281-3491

Bosch Rexroth Corporation
Mobile Hydraulics
1700 Old Mansfield Road
Wooster, OH 44691-0394
Telephone (330) 263-3300
Facsimile (330) 263-3333