

Omega Modules OBB

R310EN 2407 (2011-09)N

The Drive & Control Company



The ideal system solution for the ideal application

EasyHandling

Basic

Comfort

Advanced

Mechanical and pneumatic components, grippers, rotary compact modules, motors, sensors, single and multi-axis linear motion systems
+ pre-parameterized servo drives and start-up assistant

+ preconfigured, scalable control units

Mechanical and pneumatic components, grippers, rotary compact modules, motors, sensors, single and multi-axis linear motion systems

+ pre-parameterized servo drives and start-up assistant

Mechanical and pneumatic components, grippers, rotary compact modules, motors, sensors, single and multi-axis linear motion systems

Mechanics

Drives

Controls

With EasyHandling, Rexroth is making the automation of handling systems significantly easier, faster and more economical. EasyHandling is more than just a modular collection of mechanical components – it takes an evolutionary step forward by providing all-inclusive building systems. Its drive and control technologies, standardized interfaces, and the novel start-up assistant are all precisely matched. The perfect interaction of all these elements reduces project planning, installation and start-up times by up to 80 percent.



Basic – made-to-measure mechatronics
EasyHandling Basic includes single and multi-axis linear motion systems for all mechanical drive types. The modules are delivered complete with the matching motors or pneumatic drives. Grippers, Rotary Compact Modules and sensors ideally complement the range.



Comfort – getting started even faster
EasyHandling Comfort expands the Basic component range by adding pre-parameterized servo drives with multiple protocol capability. It also features the uniquely convenient start-up assistant EasyWizard, so that the system is ready to use after entering the data for just a few application-specific details.



Advanced – for demanding requirements
With the scalable, preconfigured Motion Logic control system, EasyHandling Advanced makes configuration and handling even easier. Predefined functions covering more than 90 percent of all handling applications eliminate the need for lengthy programming.



Contents

EasyHandling Basic	5
Product Description	5
Technical Data	10
General technical data	10
Suitable loads	11
Gear unit data	12
Drive data	13
Belt data	13
Calculations	14
Additional Technical Data	16
Deflection	16
Rigidity charts	17
OBB 55	20
Components and Ordering Data	20
Dimensions	22
OBB 85	24
Components and Ordering Data	24
Dimensions	26
OBB 120	28
Components and Ordering Data	28
Dimensions	30
Switch Mounting Arrangements – carriage stationary, frame travels	32
Switch Mounting Arrangements – frame stationary, carriage travels	34
Switches, socket-plug, cable duct	36
IndraDyn S Servo Motors	38
IndraDyn S Servo Motor MSK	38
IndraDyn S Servo Motor MSM	39
Mounting	40
Carriage with Clamping Unit	44
Carriage with clamping unit	44
Attachment of Add-on Modules	45
End plate for attachment	45
Accessories	46
Shock absorbers	46
Cable drag chains	47
EasyHandling Comfort	52
Motor-Controller Combination	52
Safety on Board – integrated, certified and consistent	53
Further Information	54
Maintenance	54
Normal operating conditions	54
Design notes	54
Intended use	54
Misuse	54
Lubrication	55
Documentation	55
Internet pages, Linear Motion and Assembly Technologies	56
Inquiry/Order	58

EasyHandling Basic

Product Description

The Tasks

– Driving, transporting, positioning

Length	Up to 5500 mm
Load capacities and moments	Load capacity C up to 79300 N Longitudinal moment M_L up to 8560 Nm Torsional moment M_t up to 970 Nm
Permissible drive torque	Up to 154 Nm
Travel speed	Up to 5 m/s
Precision	Repeatability ± 0.10 mm
Complete system	IndraDyn S servo motors with gear unit, complete with controller and control unit
Switch mounting arrangements	Mechanical and proximity switches over the entire travel range
Multiple axis unit	Combination options provided by connectors
Accessories	Clamping fixtures, motor mounts, sliding blocks, etc.
Documentation	Standard report

The Solution

Rexroth
Omega Modules OBB

EasyHandling Basic

Product Description

Omega Modules (OBB) with ball rail systems and toothed belt drive for travel speeds up to 5.0 m/s. Omega Modules are ready-to-install linear axes for any desired mounting orientation in freely configurable lengths up to 5500 mm.

Because of their low travelling system mass, Omega Modules are ideally suited for operation as vertical axes, as the drive can be mounted as a stationary unit while the module frame executes the vertical motion.

Omega Modules consist of:

- A compact, anodized aluminum profile frame
- The integrated zero-clearance Rexroth Profiled Rail System.
With its high load capacities and high rigidity this enables optimal travel performance when moving large loads at high speed.
- A carriage with one-point lubrication
- Easy-2-Combine interface in the carriage and on the end plates
- The pre-tensioned toothed belt
- Mountable switches
- Available complete with motor, controller and control unit
- Straight or angled gear reducer for attachment of motor
- Pneumatic clamping units (optional)
- Extensive range of accessories available

Sectors:

- Handling and assembly
- Electronics and semiconductor industry
- Automotive suppliers and OEMs
- Robotics and automation
- Special-purpose machines
- Packaging technology
- Building services
- Plastics processing
- Textile industry

Application areas:

- Pick and place
- Handling systems
- Component assembly systems, palletizers
- Feed units for machine tools
- Testing and analysis systems
- Feed units in transfer lines
- Load shifters

For mounting, maintenance and start-up, see the Instructions.

Attachment examples

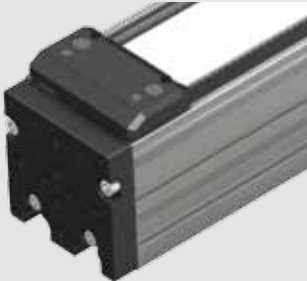

Versatile attachment mounting options are provided by the threads and locating holes on the two end plates of the frame.



Precise fastening thanks to locating holes on the carriage



Attachment of Grippers or Rotary Compact Modules



Attachment of Mini Slides

OBB as a Z-axis
 Carriage stationary, frame travels
 Motor attachment via angled gear reducer



OBB as an X-axis
 Carriage stationary, frame travels
 Motor attachment via straight gear reducer

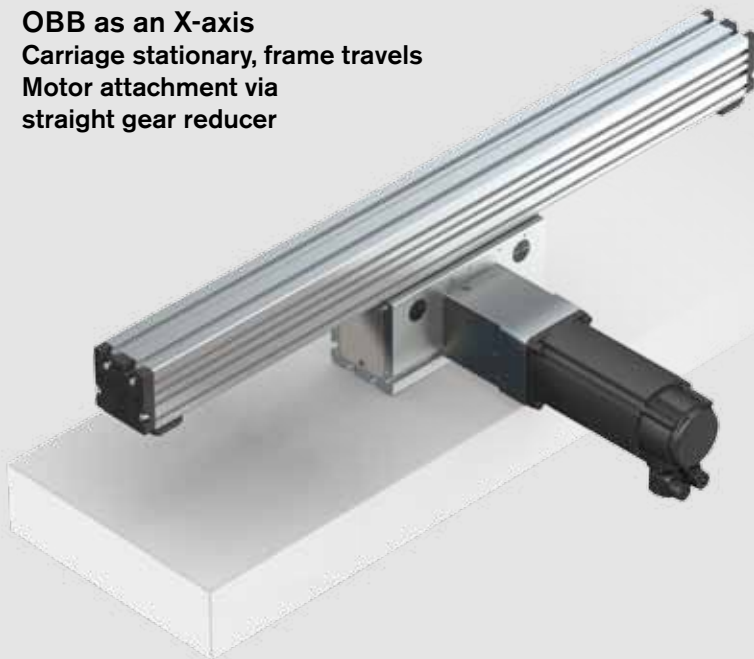

OBB as an X-axis
 Frame stationary, carriage travels
 Motor attachment via angled gear reducer

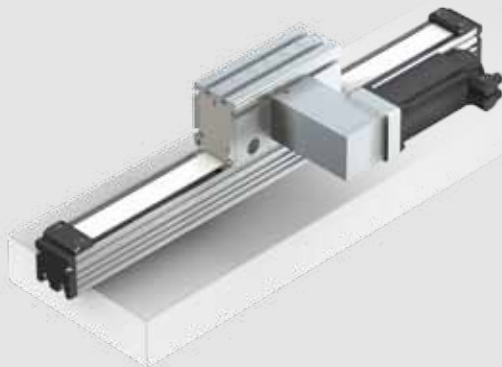

On request:
OBB with two carriages for X-axis
 Example: Carriage 1 with straight gear reducer,
 carriage 2 with angled gear reducer
 (frame stationary, carriages travel independently
 of each other)

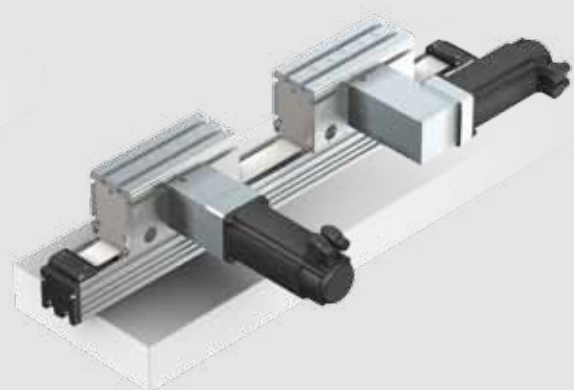

EasyHandling Basic

Type Designations, Structural Design

Type Designation (size)

Omega Modules OBB are designated according to type and size.

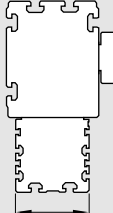
Designation Omega Module		Type			Size 85
		O	B	B	
System	Omega Module				Frame size 
Guideway	Ball Rail System				
Drive unit	Belt Drive				

Structural design (without switches)

- 1 End plate
- 2 Belt clamp
- 3 Toothed belt
- 4 Carriage with runner blocks
- 5 Frame
- 6 Clamping shaft for motor attachment
- 7 Lube port (at both end faces)
- 8 Air port (for carriage with clamping unit)
- 9 Angled gear reducer
- 10 Motor
- 11 Straight gear reducer

OBB with drive, without gear reducer (MA01)

For customer-built motor attachment

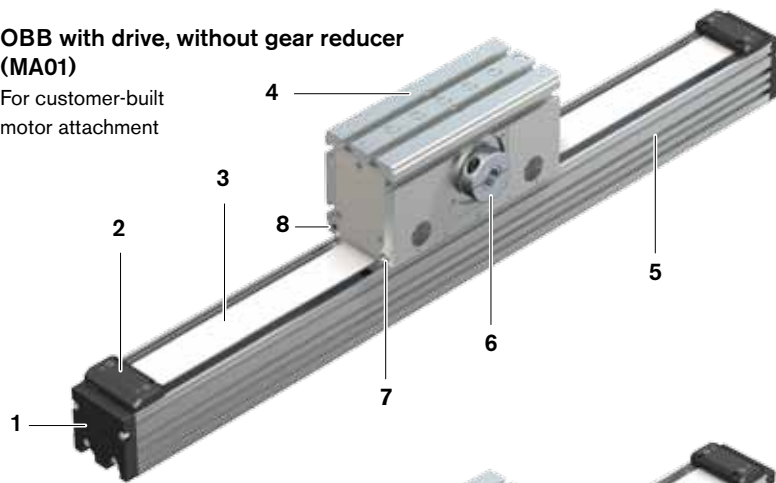

OBB with angled gear reducer (MG01 to MG04)

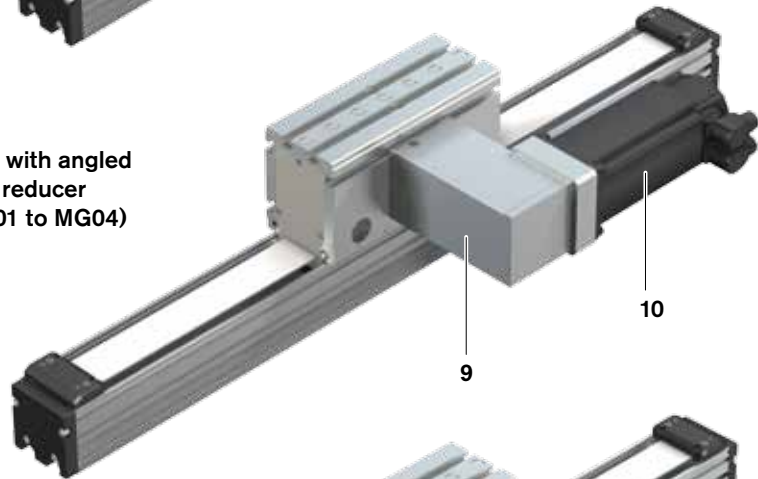

OBB with straight gear reducer (MG10)

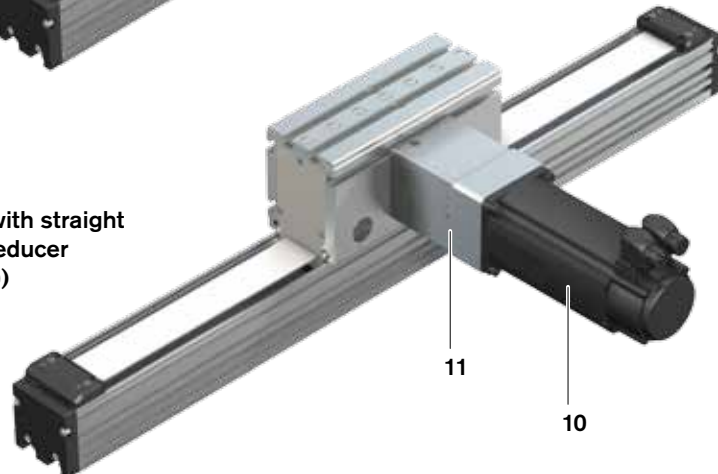

Attachments

Carriage stationary, frame travels

- 1 Switch mounting profile
- 2 Mechanical switch (with mounting accessories)
- 3 Switching strip on the frame
- 4 Proximity switch (with mounting accessories)
- 5 Socket and plug
- 6 Frame
- 7 Carriage

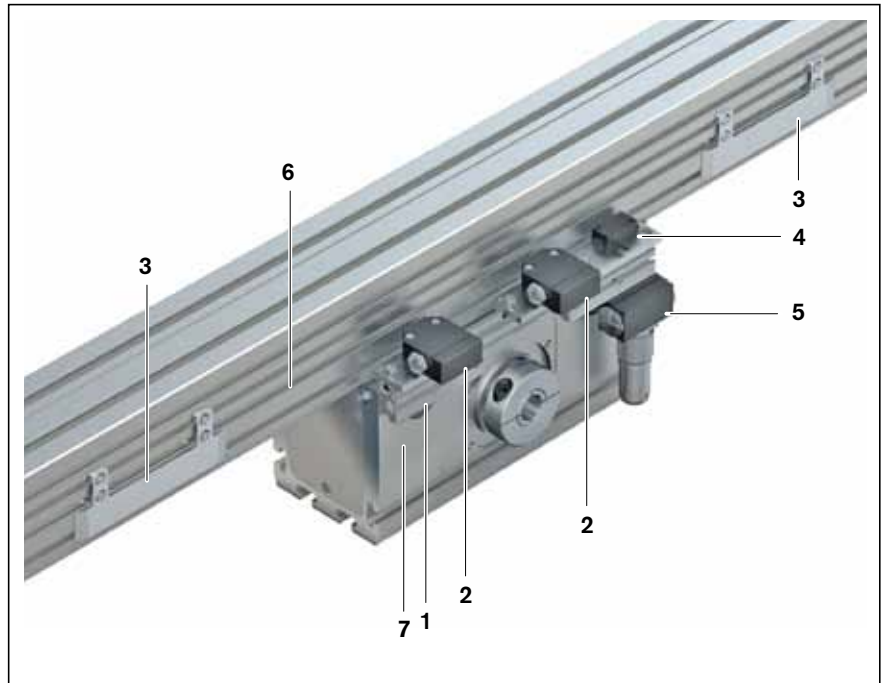

Frame stationary, carriage travels

- 1 Socket and plug
- 2 Switching strip
- 3 Mechanical switch (with mounting accessories)
- 4 Proximity switch (with mounting accessories)
- 5 Frame
- 6 Carriage

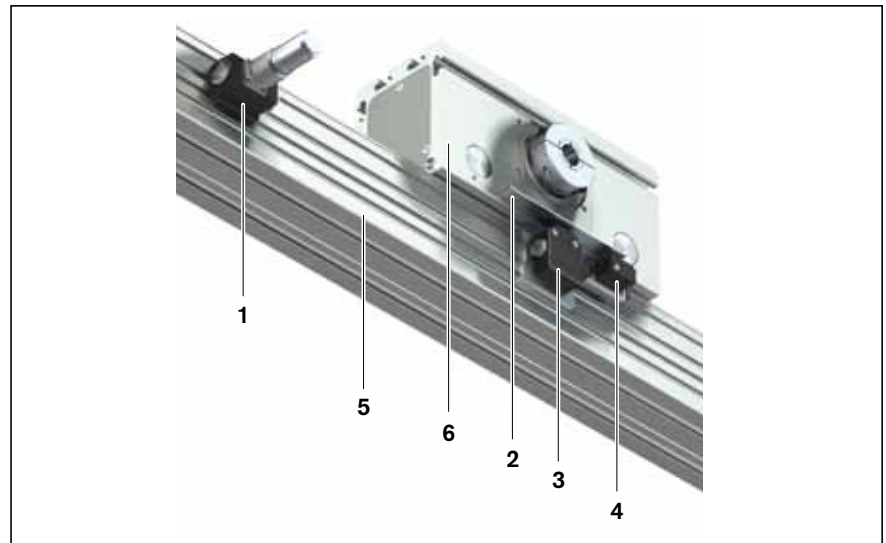

7 Shock absorbers

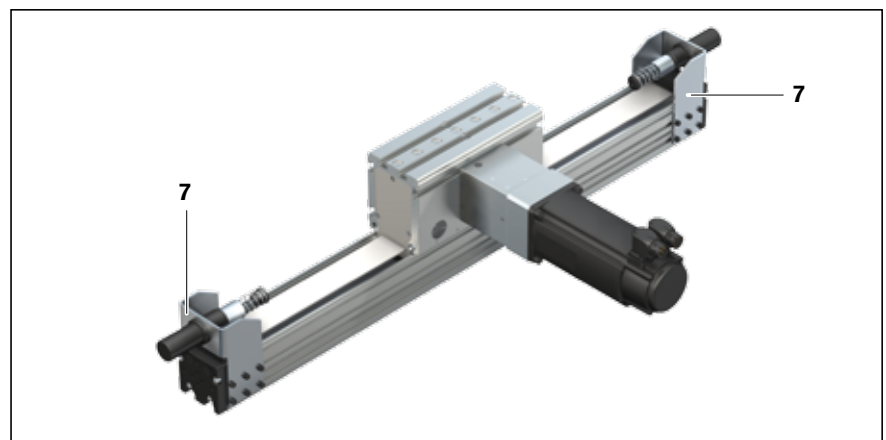

EasyHandling Basic

Technical Data

General technical data

Modulus of elasticity E

$$E = 70\,000 \text{ N/mm}^2$$

Note on dynamic load capacities and moments

Determination of the dynamic load capacities and moments is based on a travel life of 100 000 m. Often only 50 000 m are actually stipulated.
For comparison:
Multiply values C , M_t and M_L from the table by 1.26.

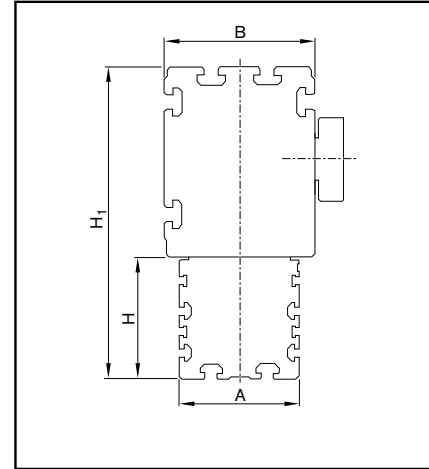

	Dimensions (mm)				Length Carriage L_{ca}	Length Omega Module		Max. drive torque for mechanical system m_{mech} (Nm)	Frictional torque of system (without gear unit, without motor) M_{Rs} (Nm)	Max. travel speed for mechanical system v_{mech} (m/s)
	A / H	B	H_1	min. $L_{min}^{1)}$		max. L_{max}				
OBB 55	55	75	135	230	450	5 500	12	0.5	5	
OBB 85	85	107	222	260	500		40	1.5		
				308	550					
OBB 120	120	135	285	330	600	154	3.5			

1) For a theoretical stroke of 100 mm

	Length Carriage L_{ca} (mm)	Dynamic load capacity C (N)	Dynamic load moments		Maximum permissible loads				Planar moment of inertia	
			M_t (Nm)	M_L (Nm)	Forces		Moments		I_y (cm ⁴)	I_z (cm ⁴)
					$F_{y max}$ (N)	$F_{z max}$ (N)	$M_x max$ (Nm)	$M_y max / M_z max$ (Nm)		
OBB 55	230	16250	156	1100	6500	6500	62	440	24	39
OBB 85	260	49400	700	3750	19760	19760	280	1500	148	244
OBB 120	330	79300	970	8560	31700	31720	388	3424	664	725

		Holding force Clamping unit (N)	Moved mass of system (kg)		Mass of the linear system (w/o motor, w/o gear unit) m_s (kg)
			Carriage travels (w/o motor, w/o gear unit)	Frame travels	
OBB 55	w/o clamping unit	–	3.82	$0.0043 \cdot L + 0.55$	$0.0043 \cdot L + 4.37$
	with clamping unit	370	4.01		$0.0043 \cdot L + 4.56$
OBB 85	w/o clamping unit	–	9.56	$0.0108 \cdot L + 1.05$	$0.0108 \cdot L + 10.6$
	with clamping unit	690	11.3		$0.0108 \cdot L + 12.3$
OBB 120	w/o clamping unit	–	17.7	$0.0171 \cdot L + 3.08$	$0.0171 \cdot L + 20.8$
	with clamping unit	1200	18.4		$0.0171 \cdot L + 21.5$

Mass of the linear system

Weight calculation does not include motor or switch attachments.

Weight formula:

Weight factor (kg/mm) x length L (mm) + weight of all parts of fixed length (carriage, end plates, etc.) (kg)

Suitable loads

As far as the desired service life is concerned, loads of up to approximately 20% of the dynamic characteristic values (C , M_t , M_L) have proved acceptable.

At the same time, the following may not be exceeded:

- the permissible drive torque
- the maximum permissible loads
- the permissible travel speed
- the maximum permissible deflection

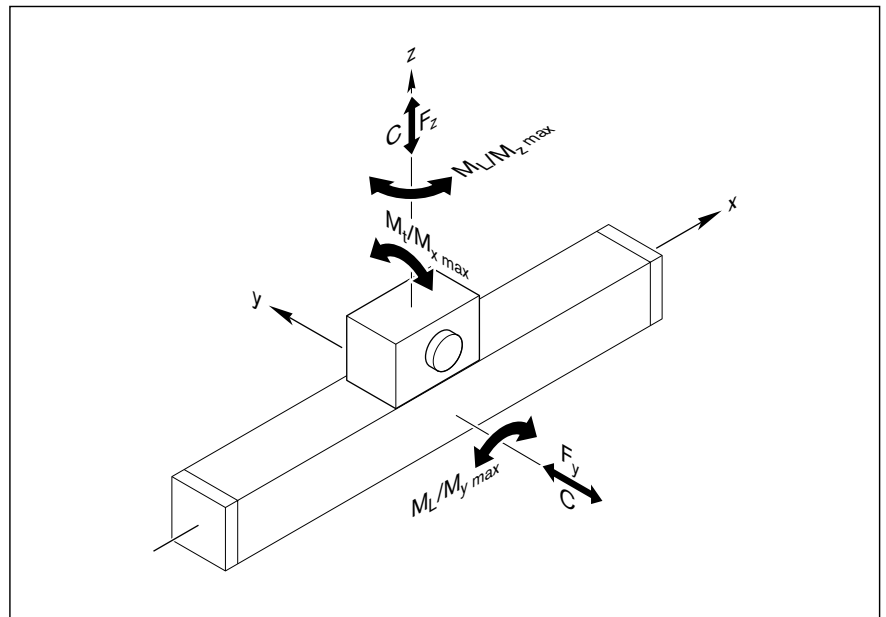

EasyHandling Basic

Technical Data

Constants $k_{J \text{ fix}}$, $k_{J \text{ var}}$, $k_{J \text{ m}}$

The constants are required to determine the mass moment of inertia of the system J_s .
Values without gear unit, and without motor

		Constants		
		$k_{J \text{ fix}}$	$k_{J \text{ var}}$	$k_{J \text{ m}}$
OBB 55	Carr.	3370	0	690
	Frame	580	3.04	690
OBB 85	Carr.	15050	0	1650
	Frame	2730	18.06	1650
OBB 120	Carr.	52600	0	2950
	Frame	13700	50.50	2950

Carr. = traveling carriage

Frame = traveling frame

Gear unit data

Frictional torque of gear M_{Rge}

	Gear reducer ratio	Gear unit	M_{Rge} (Nm)	Weight (kg)	Mass moment of inertia J_s ($\text{kgm}^2 \cdot 10^{-6}$)
OBB 55	1	–	–	–	–
	3	SG	0.15	1.1	13.5
	5	SG	0.10	1.1	7.8
	8	SG	0.10	1.1	6.5
	3	AG	0.30	1.9	24.6
	5	AG	0.25	1.9	18.9
	8	AG	0.20	1.7	17.6
	OBB 85	1	–	–	–
5		SG	0.40	3.5	45.0
8		SG	0.25	3.5	39.0
5		AG	0.70	5.8	86.9
8		AG	0.55	5.8	80.9
OBB 120	1	–	–	–	–
	9	SG	0.90	7.8	262.0
	9	AG	1.35	13.8	573.0

SG = straight gear reducer

AG = angled gear reducer

Drive data

	Gear reducer ratio i	Max. drive torque for mechanical system M _a	Lead constant
	(-)	(Nm)	(mm/rev)
OBB 55	1 (w/o gear unit)	12.0	165.00
	3	4.0	55.00
	5	2.4	33.00
	8	1.5	20.63
OBB 85	1 (w/o gear unit)	40.0	255.00
	5	8.0	51.00
	8	5.0	31.87
OBB 120	1 (w/o gear unit)	154.0	340.00
	9	17.1	37.77

Belt data

	Belt type	Width	Tooth pitch	Max. belt drive transmission force	Cord strength	Specific spring rate C _{spec}
		(mm)	(mm)	(N)	(N)	(N)
OBB 55	25 AT 5	25	5	460	1750	0.44 · 10 ⁶
OBB 85	50 AT 5	50	5	992	3500	0.875 · 10 ⁶
OBB 120	70 AT 10	70	10	2844	11750	2.968 · 10 ⁶

EasyHandling Basic

Calculations

Calculation principles

Maximum permissible load

$$\frac{|F_y|}{F_{y\max}} + \frac{|F_z|}{F_{z\max}} + \frac{|M_x|}{M_{x\max}} + \frac{|M_y|}{M_{y\max}} + \frac{|M_z|}{M_{z\max}} \leq 1$$

Combined equivalent load on bearing of the linear guide

$$F_{\text{comb}} = |F_y| + |F_z| + C \cdot \frac{|M_x|}{M_t} + C \cdot \frac{|M_y|}{M_L} + C \cdot \frac{|M_z|}{M_L}$$

	Dimension (mm)	Z ₁
OBB 55		76.0
OBB 85		126.5
OBB 120		138.0

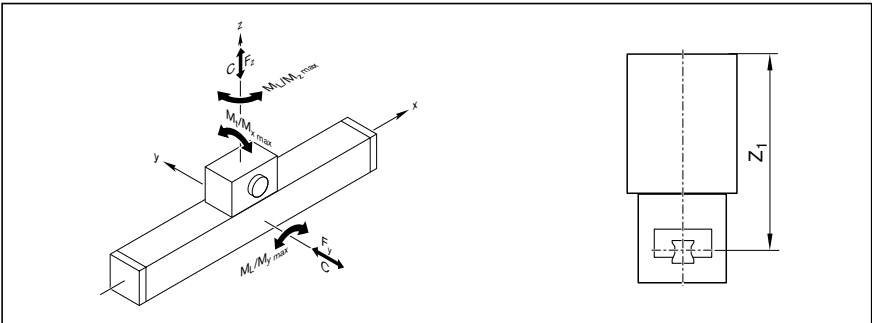

Service life

Nominal life of the guideway in meters:

$$L = \left(\frac{C}{F_{\text{comb}}} \right)^3 \cdot 10^5$$

Nominal life of the guideway in hours:

$$L_h = \frac{L}{3600 \cdot v_m}$$

Frictional torque with drive unit without gear reducer (MA01)

$$M_R = M_{Rs}$$

with gear reducer (MG)

$$M_R = \frac{M_{Rs}}{i} + M_{Rge}$$

Mass moment of inertia of the linear motion system J_s referred to the drive journal

$$J_s = (k_{J \text{ fix}} + k_{J \text{ var}} \cdot L) \cdot 10^{-6}$$

- C = dynamic load capacity (N)
- F_{comb} = combined equivalent load on bearing (N)
- F_y = force in y-direction (N)
- F_z = force in z-direction (N)
- i = gear ratio
- J_s = mass moment of inertia of linear motion system (without external load) (kgm²)
- k_{J fix} = constant for fixed-length portion of mass moment of inertia (-)
- k_{J var} = constant for variable-length portion of mass moment of inertia (-)
- L = nominal life in meters (m)
- L_h = nominal life in hours (h)
- M_L = dynamic longitudinal moment load capacity (Nm)
- M_R = frictional torque at motor journal (Nm)
- M_{Rs} = frictional torque of system (Nm)
- M_{Rge} = frictional torque of gear at motor journal (Nm)
- M_t = dynamic torsional moment load capacity (Nm)
- M_x = torsional moment about the x-axis (Nm)
- M_y = torsional moment about the y-axis (Nm)
- M_z = torsional moment about the z-axis (Nm)
- v_m = average travel speed (m/s)
- Z₁ = application point of the effective force (mm)

Mass moment of inertia of the mechanical system referred to the motor journal

Motor attachment without gear reducer (MA01)

$$J_{ex} = J_s + J_t + J_c$$

with gear reducer (MG)

$$J_{ex} = \frac{J_s + J_t}{i^2} + J_{ge}$$

Translatory mass moment of inertia of external load referred to the drive journal

$$J_t = m_{ex} \cdot k_{Jm} \cdot 10^{-6}$$

Mass moment of inertia of the drive train referred to the motor journal

$$J_{dc} = J_{ex} + J_{br}$$

Mass moment of inertia ratio

$$V = \frac{J_{dc}}{J_m}$$

Application area	V
Handling	≤ 6.0
Processing	≤ 1.5

Total mass moment of inertia referred to the motor journal

$$J_{tot} = J_{dc} + J_m$$

Maximum permissible rotary speed for mechanical system

$$n_{mech} = \frac{v_{mech} \cdot i \cdot 1000 \cdot 60}{v}$$

$$n_{mech} < n_{m \max}$$

- J_{br} = mass moment of inertia, motor brake (kgm²)
- J_c = mass moment of inertia, coupling (kgm²)
- J_{dc} = mass moment of inertia, drive train (kgm²)
- J_{ex} = mass moment of inertia of mechanical system (kgm²)
- J_m = mass moment of inertia, motor (kgm²)
- J_s = mass moment of inertia of linear motion system (without external load) (kgm²)
- J_{ge} = mass moment of inertia of gear at motor journal (kgm²)
- J_t = translatory mass moment of inertia of external load referred to the drive journal (kgm²)
- J_{tot} = total mass moment of inertia (kgm²)
- i = gear ratio of gear reducer (-)
- k_{Jm} = constant for mass-specific portion of mass moment of inertia (10⁶ m²)
- m_{ex} = moved external load (kgm³)
- $n_{m \max}$ = maximum permissible rotary speed of motor with controller (min⁻¹)
- n_{mech} = maximum permissible rotary speed of mechanical system (min⁻¹)
- v = lead constant (mm)
- V = ratio of mass moments of inertia of drive train and motor (-)
- v_{mech} = maximum permissible linear speed of mechanical system (m/s)

EasyHandling Basic

Additional Technical Data

Deflection

A special feature of Omega Modules is the possibility to mount them by the carriage, which remains stationary while the frame travels.

Deflection of the frame must, however, be taken into consideration, because it limits the possible load.

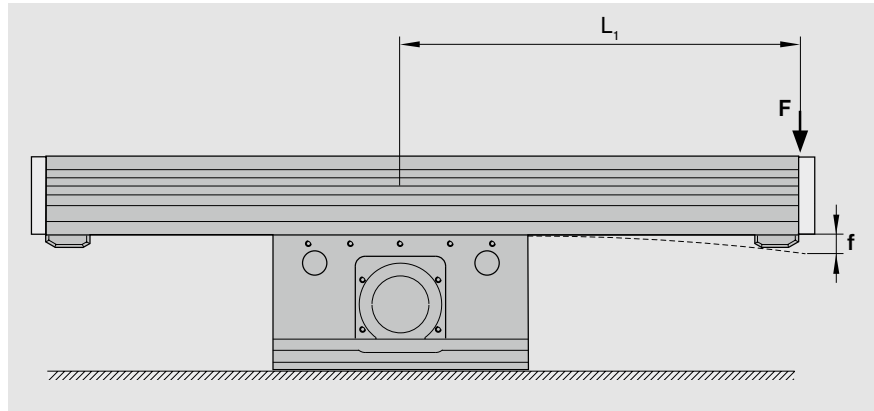

Example

Omega Modules OBB 85:

$L_1 = 1000$ mm

$F = 400$ N

From the OBB 85 diagram (load applied in the z-direction): $f = 1.6$ mm

The deflection f can affect the precision. Users should check whether the deviation is within the tolerance limits.

Rigidity charts for loads from the z and y directions

The graphs apply under the following conditions: 4 clamping fixtures per side, 8 screws per side, solid mounting base

OBB 55

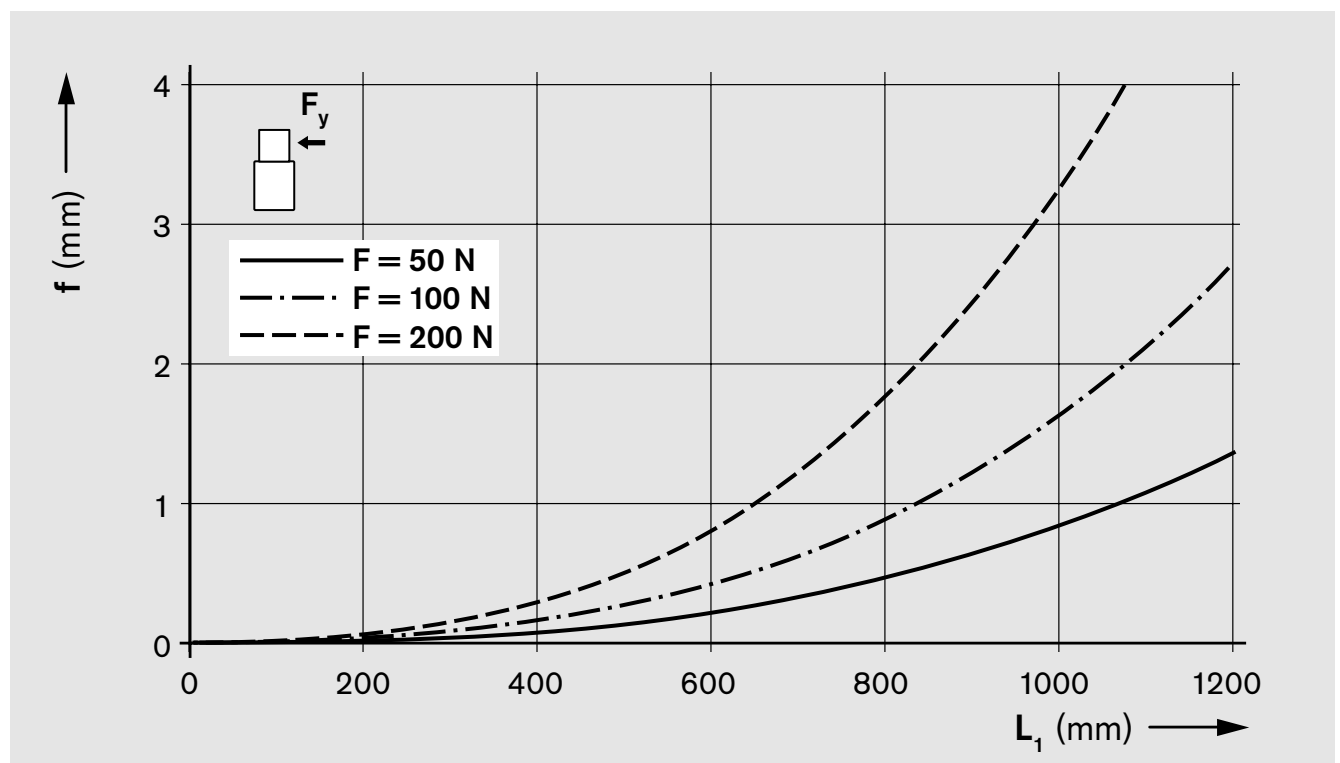
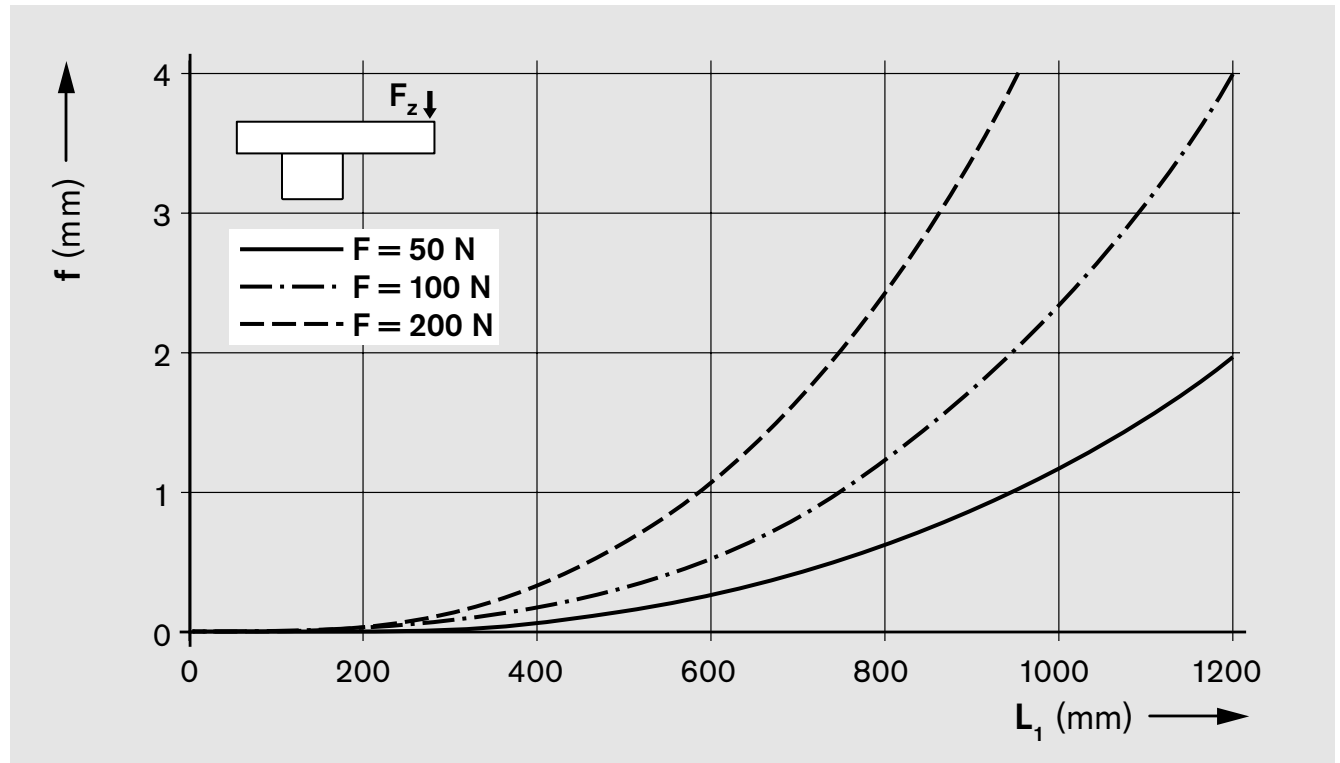

EasyHandling Basic

Additional Technical Data

Rigidity charts for loads from the z and y directions

OBB 85

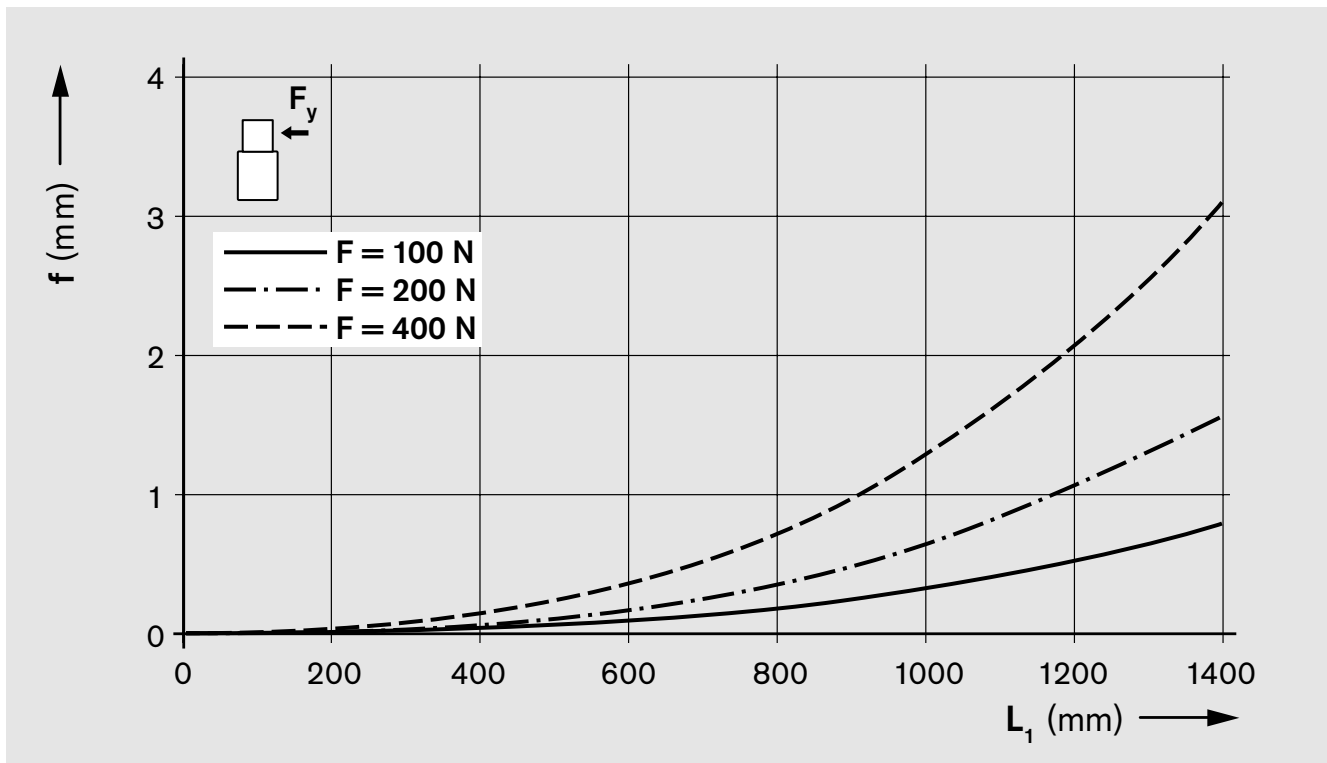
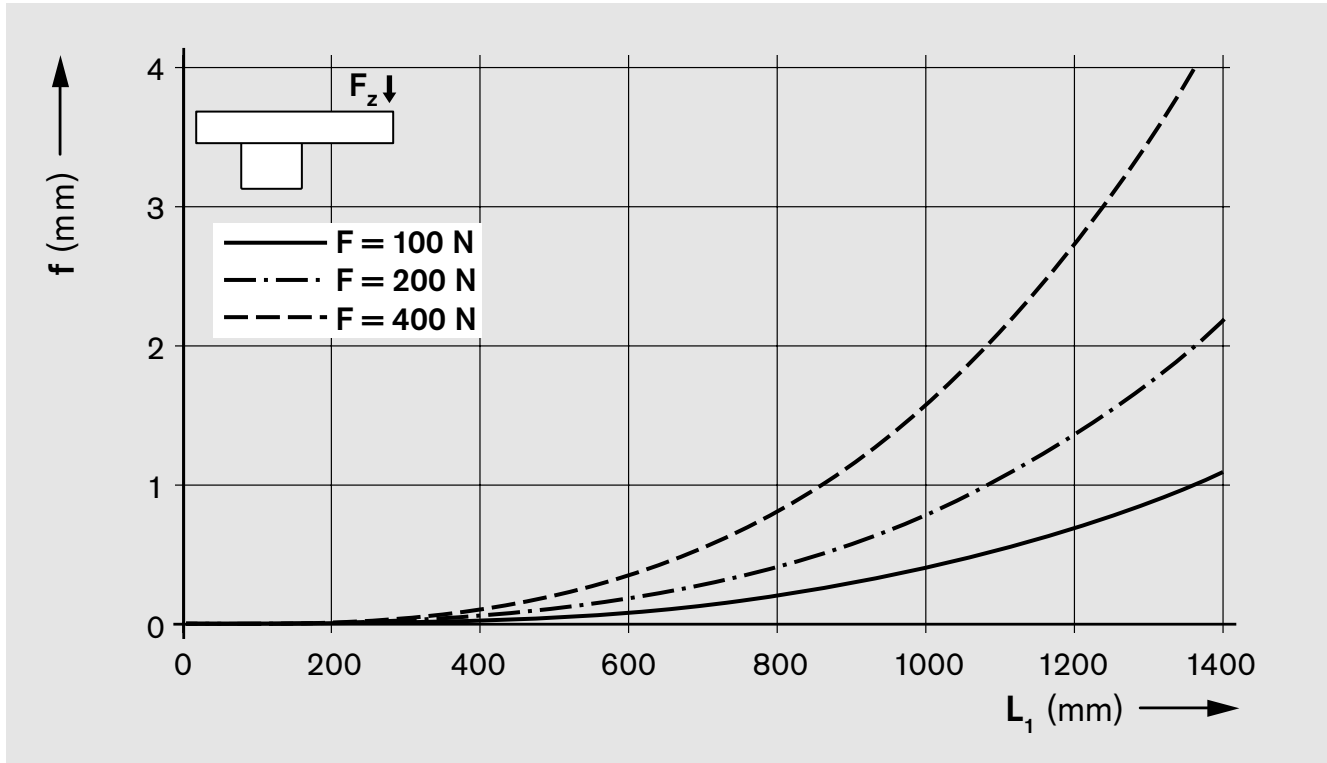

OBB 120

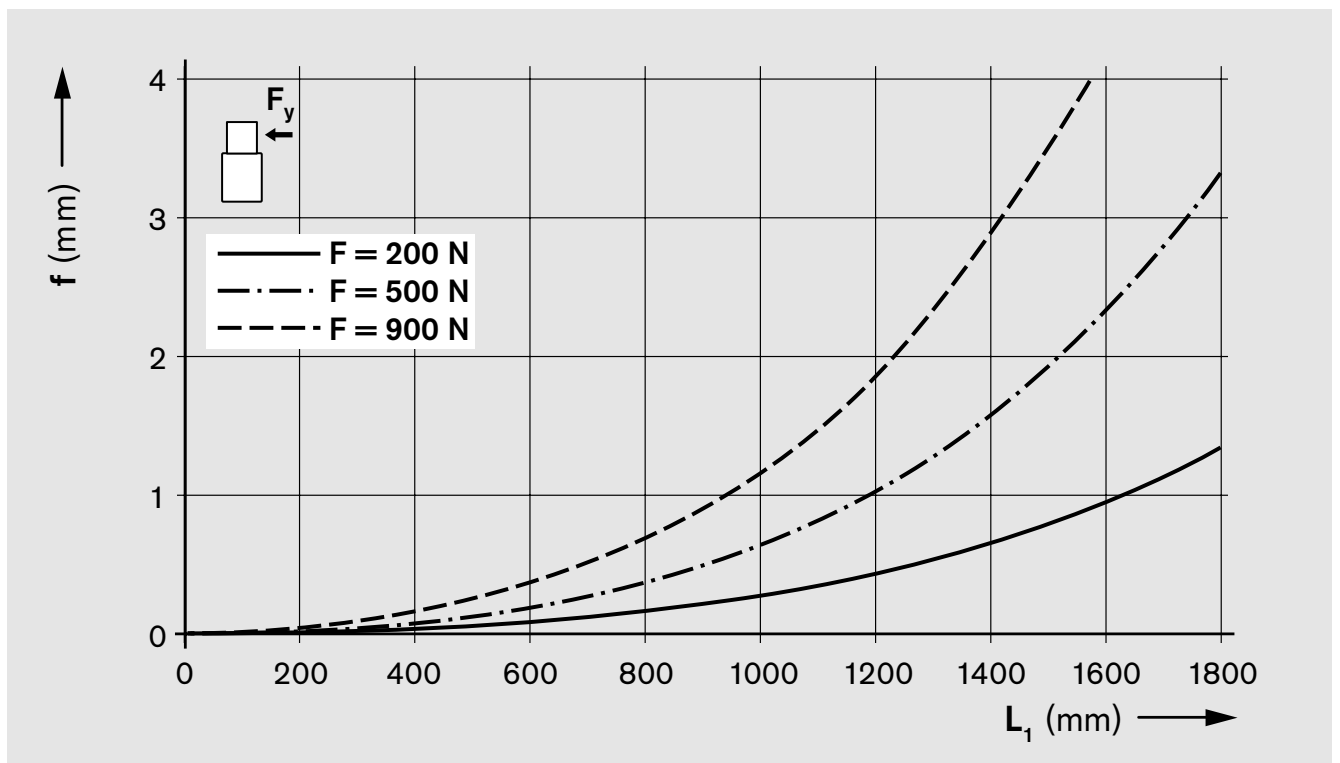
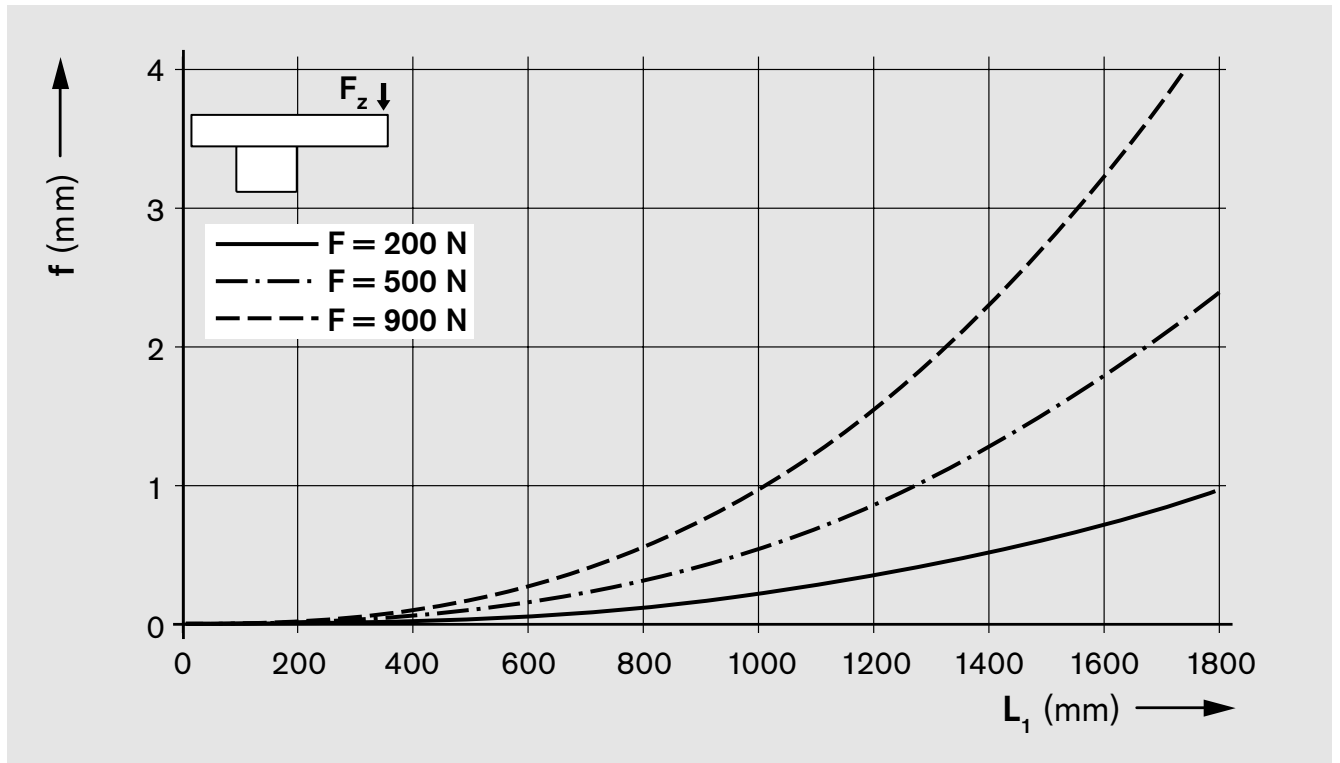

EasyHandling Basic

OBB 55

Components and Ordering Data

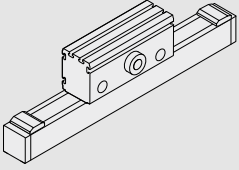
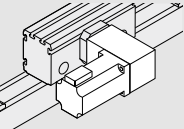
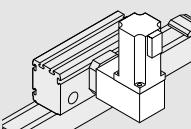
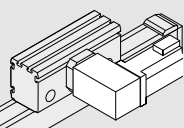
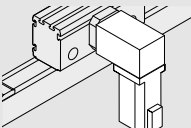
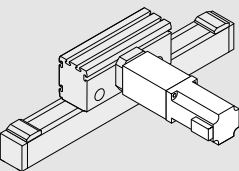
Part number, length R1144 100 00, mm		Guideway	Drive unit				Carriage	
Version			Reduction				$L_{ca} = 230\text{ mm}$	$L_{ca} = 266\text{ mm}$
			i = 1	i = 3	i = 5	i = 8	without	with
							Clamping unit	
With drive unit (MA), w/o gear reducer $i=1$	MA01		01	Clamping shaft	01	-	01	02
	MG01		01	Angled gear reducer at left / at top / at right / at bottom	-	10	01	02
With gear reducer (MG), angled gear reducer WPLE	MG02							
	MG03							
With gear reducer (MG), straight gear reducer PLE	MG04		01	Straight gear reducer at side	-	10	01	02
	MG10							

Ordering example: see "Inquiry/Order"

L_{ca} = carriage length

Please check whether the selected combination is a permissible one (load capacities, moments, maximum speeds, motor data, etc.)!

Motor attachment				Motor		Switches / Cable duct / Socket-plug		Documentation	
Reduction i =	Attachment kit ¹⁾		for motor	without with Brake					
	MG01 MG03	MG02 MG04							
-	00		-	00	Without switch and cable duct		00		01
					Carriage travels				
					Switches:				
					- PNP NC		71 ± ... mm		
					- PNP NO		73 ± ... mm		
					- Mechanical		75 ± ... mm		
					Ordering data:				
					Switch type		_____		
					Travel direction		_____		
					Switching distance		_____		
					Cable duct - length		20 - ... mm		
					Socket-plug		17		
					One switching strip		36		
					Frame travels				
					Switches:				
					- PNP NC		61 ± ... mm		
					- PNP NO		63 ± ... mm		
					- Mechanical		65 ± ... mm		
					Socket-plug		17		
					One switching strip		38		
					Two switching strips		39		

1) Attachment kit also available without motor (when ordering: enter "00" for motor)

Length L:

$$L = (\text{effective stroke} + 2 \cdot \text{excess travel } s_e) + 130 \text{ mm} + L_{ca}$$

Effective stroke = maximum travel of carriage center (CC) between the outermost switch activation points.

The excess travel s_e must be longer than the braking distance. The acceleration travel can be taken as a guideline value for the braking distance.

⚠ Note for length calculations for the version "Carriage without clamping unit":
The switch mounting profile is 260 mm long.
Add 30 mm to the calculated length L.

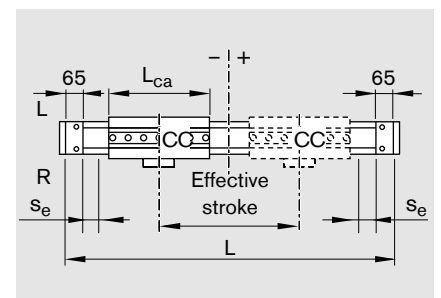

EasyHandling Basic

OBB 55

Dimensions

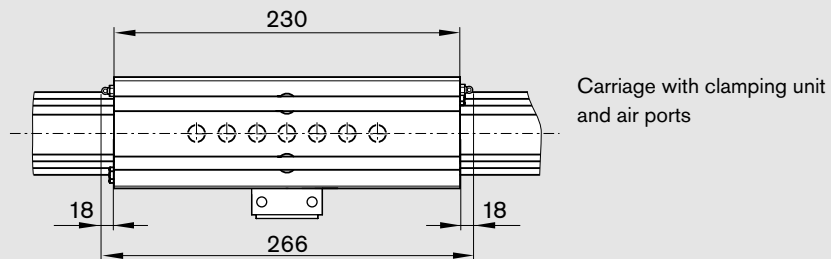
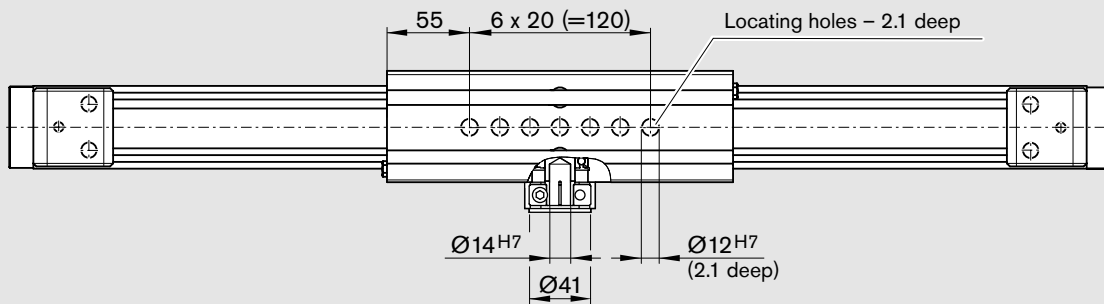
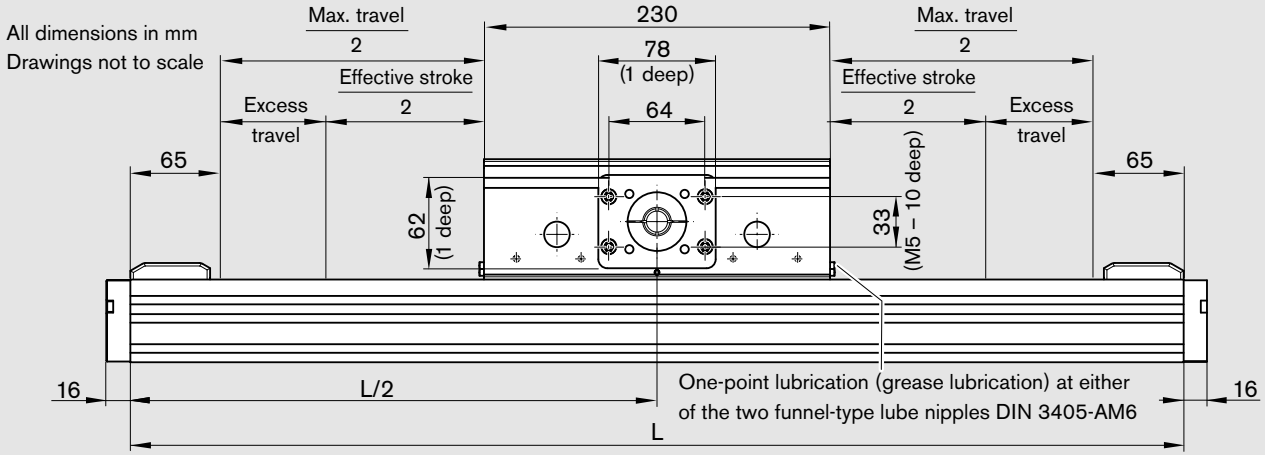

MA01

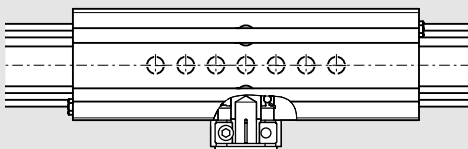

MG01, MG02, MG03, MG04

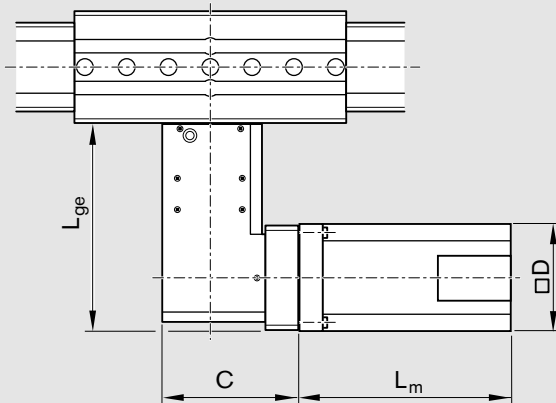

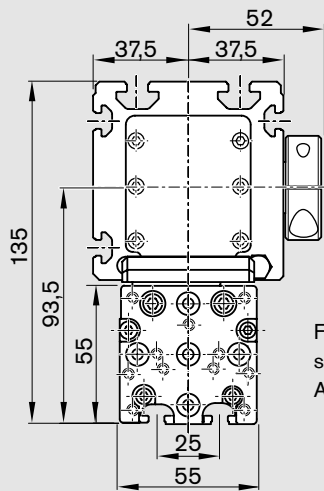

For dimensions of end plate, see section "Attachment of Add-on Modules"

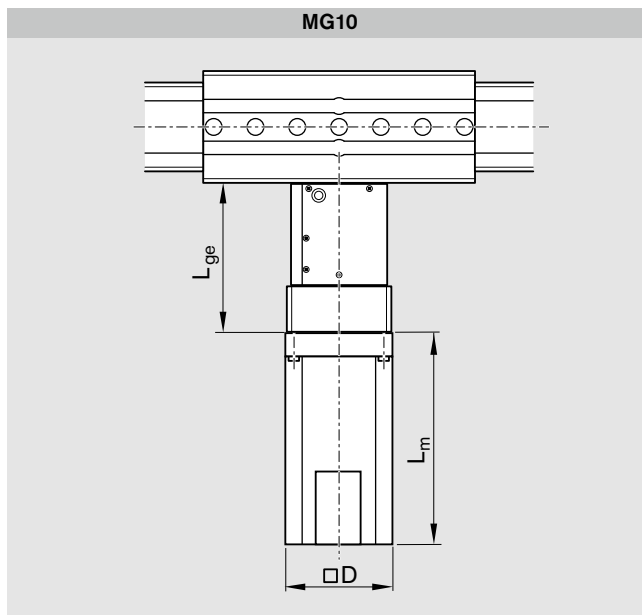
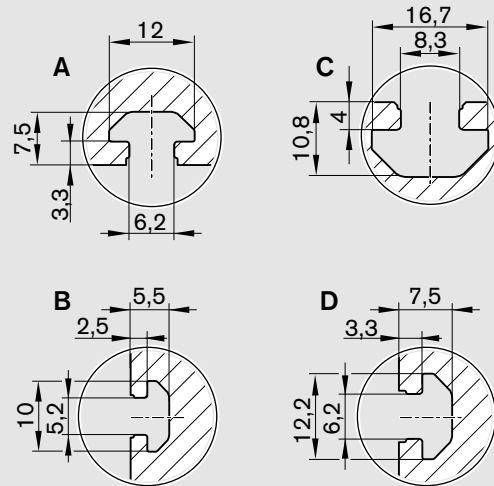
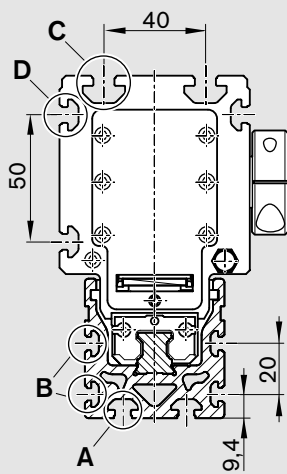
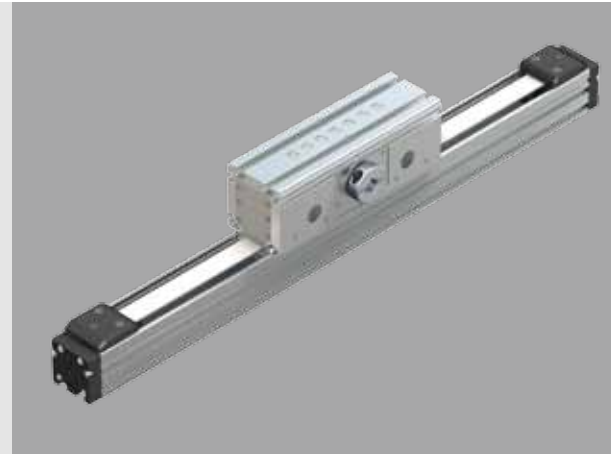

Motor	Dimensions (mm)					
	Gear unit		Motor			
	L_{ge}	C	L_{ge}	D	without brake	L_m with brake
MSK 040C	150.5	97.5	111.5	82	185.5	215.5
MSM 031C	135.5	97.5	111.5	60	98.5	135

EasyHandling Basic

OBB 85

Components and Ordering Data

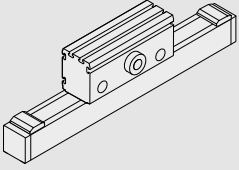
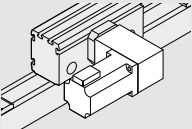
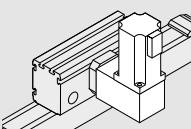
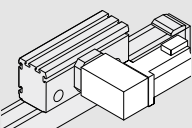
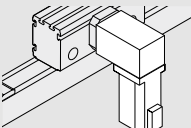
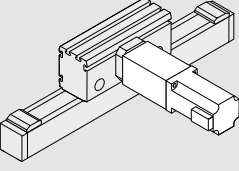
Part number, length R1144 300 00, mm		Guideway	Drive unit			Carriage	
Version			Reduction			$L_{ca} = 260$ mm without	$L_{ca} = 344$ mm with
			i = 1	i = 5	i = 8	Clamping unit	Clamping unit
With drive unit (MA), w/o gear reducer i=1	MA01 	01	Clamping shaft	01	-	01	02
With gear reducer (MG), angled gear reducer WPLE	MG01 	01	Angled gear reducer at left / at top / at right / at bottom	-	10	01	02
	MG02 						
	MG03 						
	MG04 						
With gear reducer (MG), straight gear reducer PLE	MG10 	01	Straight gear reducer at side	-	10	01	02

Ordering example: see "Inquiry/Order"

L_{ca} = carriage length

Please check whether the selected combination is a permissible one (load capacities, moments, maximum speeds, motor data, etc.)!

Motor attachment				Motor		Switches / Cable duct / Socket-plug		Documentation	
Reduction i =	Attachment kit ¹⁾		for motor	without	with			Standard report	
	MG01 MG03	MG02 MG04							
-	00		-	00		Without switch and cable duct 00 <hr/> Carriage travels Switches: - PNP NC 71 ± ... mm - PNP NO 73 ± ... mm - Mechanical 75 ± ... mm Ordering data: Switch type _____ Travel direction _____ Switching distance _____ <hr/> Cable duct – length 20 - ... mm <hr/> Socket-plug 17 <hr/> One switching strip 36		01	
i = 5	33	43	MSK 050C	88	89				
i = 8	35	45							
i = 8	34	44	MSM 041B	110	111				
i = 5	30		MSK 050C	88	89	<hr/> Frame travels Switches: - PNP NC 61 ± ... mm - PNP NO 63 ± ... mm - Mechanical 65 ± ... mm <hr/> Socket-plug 17 <hr/> One switching strip 40 <hr/> Two switching strips 41			
i = 8	32								
i = 8	31		MSM 041B	110	111				

1) Attachment kit also available without motor (when ordering: enter "00" for motor)

Length L:

$$L = (\text{effective stroke} + 2 \cdot \text{excess travel } s_e) + 120 \text{ mm} + L_{ca}$$

Effective stroke = maximum travel of carriage center (CC) between the outermost switch activation points.

The excess travel s_e must be longer than the braking distance. The acceleration travel can be taken as a guideline value for the braking distance.

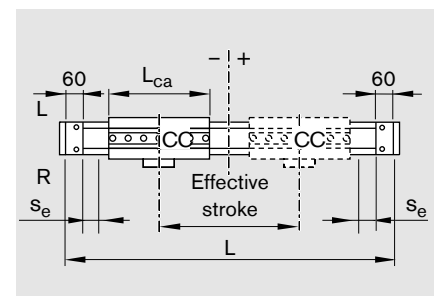

EasyHandling Basic

OBB 85

Dimensions

All dimensions in mm
Drawings not to scale

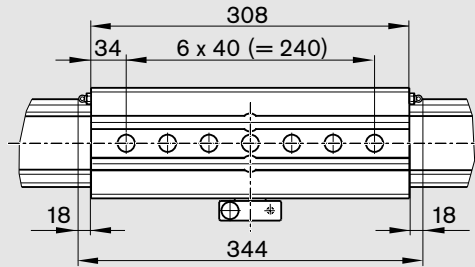
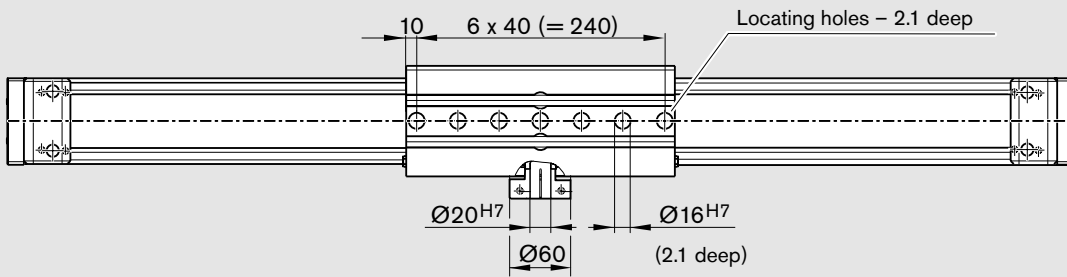
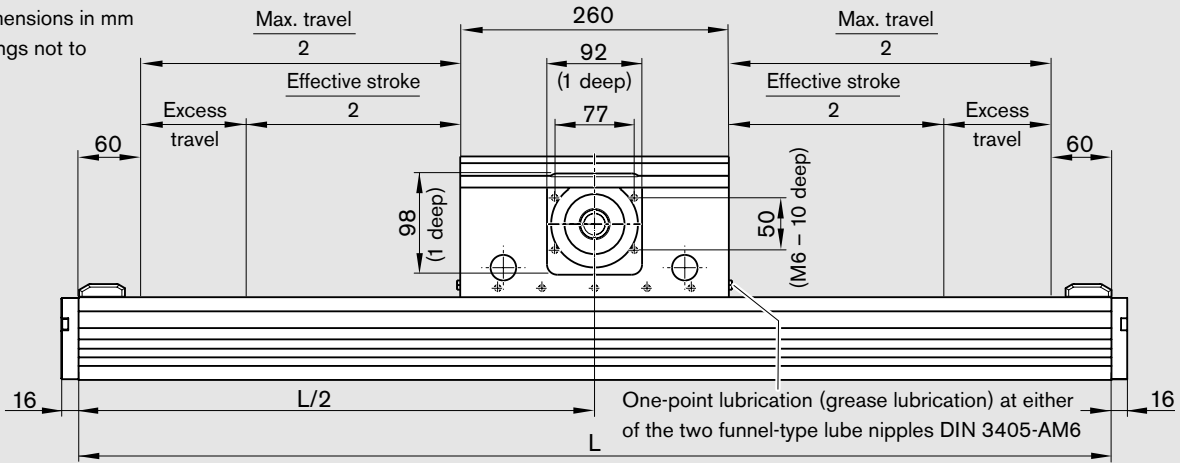

Carriage with clamping unit and air ports

MA01

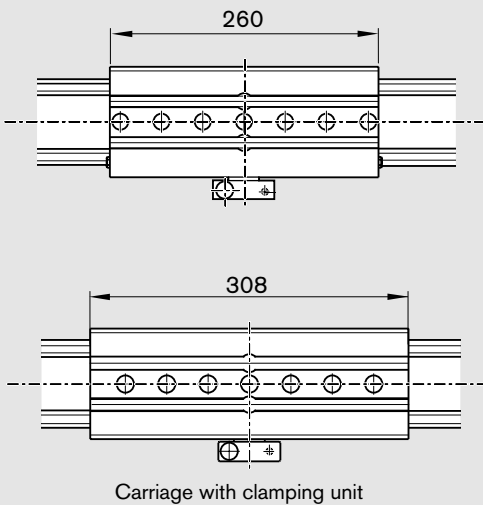

MG01, MG02, MG03, MG04

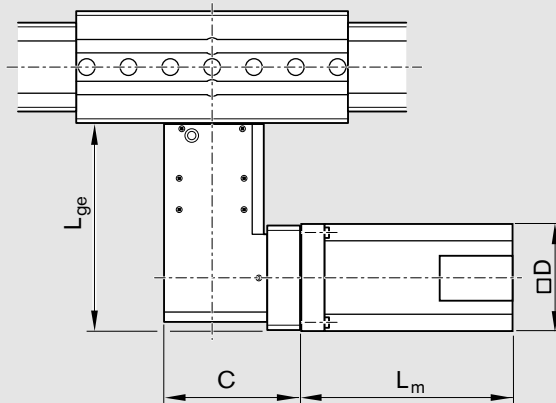

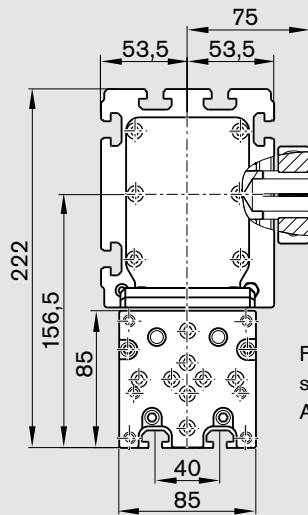

For dimensions of end plate, see section "Attachment of Add-on Modules"

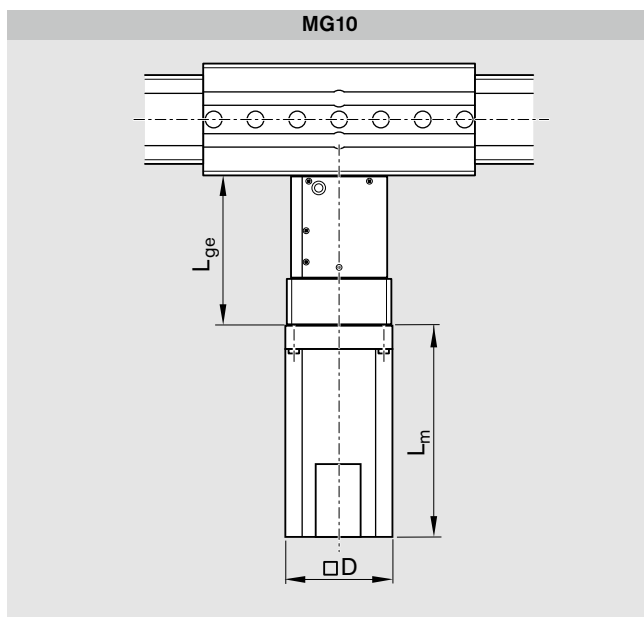
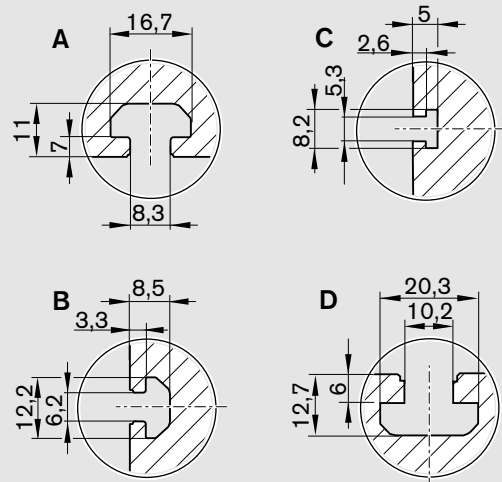
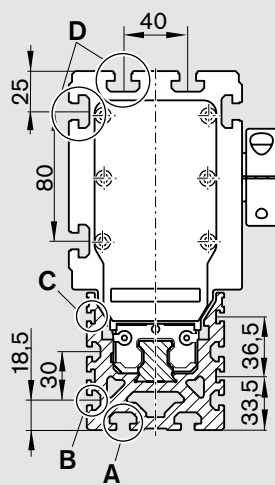
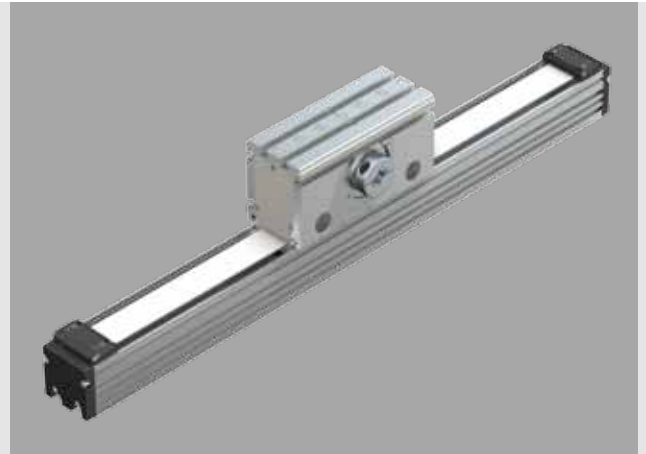

Motor	Dimensions (mm)					
	Gear unit		Motor			
	L_{ge}	C	L_{ge}	D	without brake	L_m with brake
MSK 050C	192.5	124.5	142	98	203.0	233.0
MSM 041B	187.5	124.5	142	80	112.0	149.0

EasyHandling Basic

OBB 120

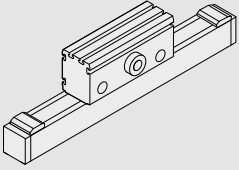
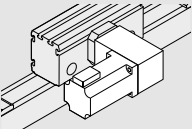
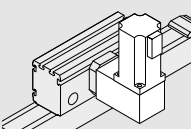
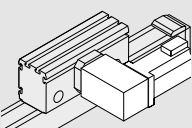
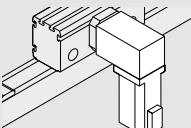
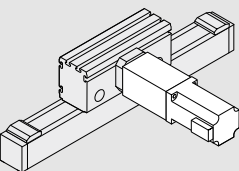

Components and Ordering Data

Part number, length R1144 600 00, mm		Guideway	Drive unit		Carriage		
Version			Reduction		$L_{ca} = 330\text{ mm}$ without Clamping unit	$L_{ca} = 366\text{ mm}$ with Clamping unit	
			$i = 1$	$i = 9$			
With drive unit (MA), w/o gear reducer $i=1$	MA01 	01	Clamping shaft	01	-	01	02
With gear reducer (MG), angled gear reducer WPLE	MG01 	01	Angled gear reducer at left / at top / at right / at bottom	-	10	01	02
	MG02 						
With gear reducer (MG), angled gear reducer PLE	MG03 	01	Straight gear reducer at side	-	10	01	02
	MG04 						
With gear reducer (MG), straight gear reducer PLE	MG10 	01					

Ordering example: see "Inquiry/Order"

L_{ca} = carriage length

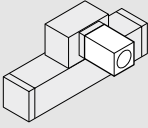
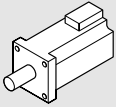
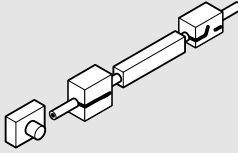
Please check whether the selected combination is a permissible one (load capacities, moments, maximum speeds, motor data, etc.)!

Motor attachment				Motor	Switches / Cable duct / Socket-plug	Documentation
						 Standard report
Reduction $i =$	Attachment kit ¹⁾ MG01 MG02 MG03 MG04		for motor	without with Brake		
-	00		-	00	Without switch and cable duct 00 <hr/> Carriage travels Switches: - PNP NC 71 ± ... mm - PNP NO 73 ± ... mm - Mechanical 75 ± ... mm Ordering data: Switch type _____ Travel direction _____ Switching distance _____ <hr/> Cable duct – length 20 - ... mm <hr/> Socket-plug 17 <hr/> One switching strip 36 <hr/> Frame travels Switches: - PNP NC 61 ± ... mm - PNP NO 63 ± ... mm - Mechanical 65 ± ... mm <hr/> Socket-plug 17 <hr/> One switching strip 42 <hr/> Two switching strips 43	01
$i = 9$	31	32	MSK 076C	92 93		
$i = 9$	30		MSK 076C	92 93		

1) Attachment kit also available without motor (when ordering: enter "00" for motor)

Length L:

$$L = (\text{effective stroke} + 2 \cdot \text{excess travel } s_e) + 170 \text{ mm} + L_{ca}$$

Effective stroke = maximum travel of carriage center (CC) between the outermost switch activation points.

The excess travel s_e must be longer than the braking distance. The acceleration travel can be taken as a guideline value for the braking distance.

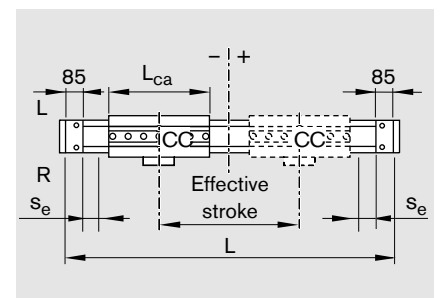

EasyHandling Basic

OBB 120

Dimensions

All dimensions in mm
Drawings not to scale

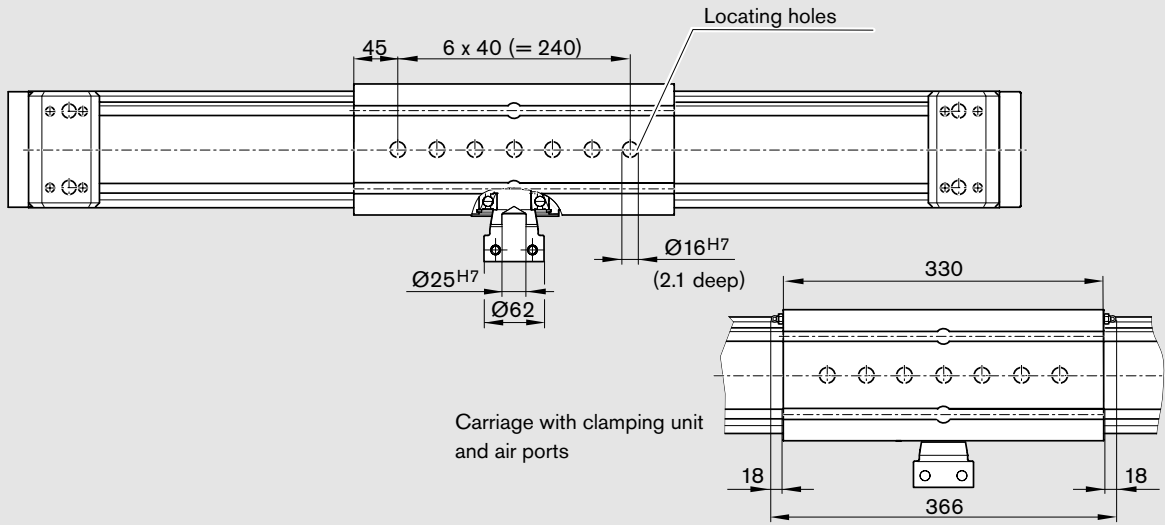
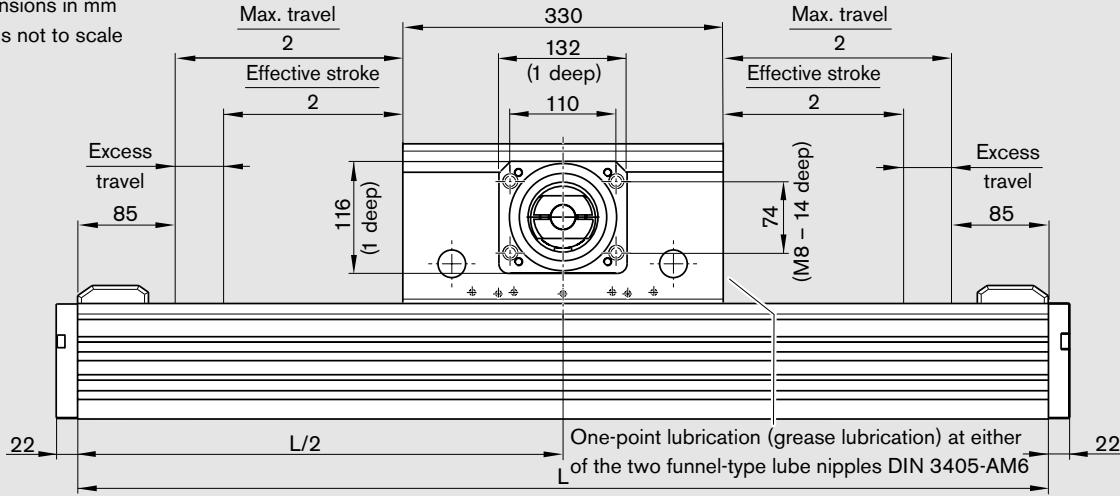

MA01

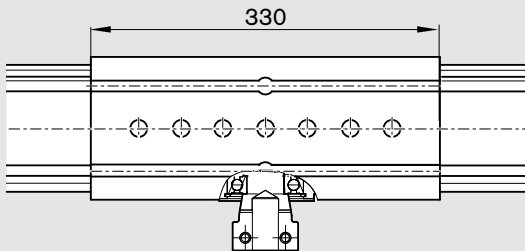

MG01, MG02, MG03, MG04

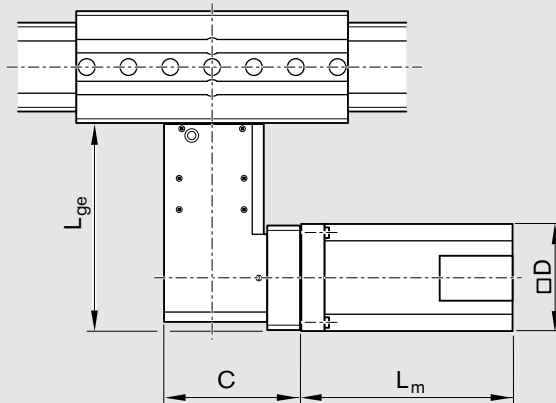

EasyHandling Basic

Switch Mounting Arrangements – carriage stationary, frame travels

Switching principle

- Proximity or mechanical switches on the carriage (carr.)
- Switching via switching strips on the frame

Overview of switching system

- 1 Switch mounting profile
- 2 Mechanical switches (with mounting accessories)
- 3 Switching strips on the frame
- 4 Proximity switch (with mounting accessories)
- 5 Socket and plug

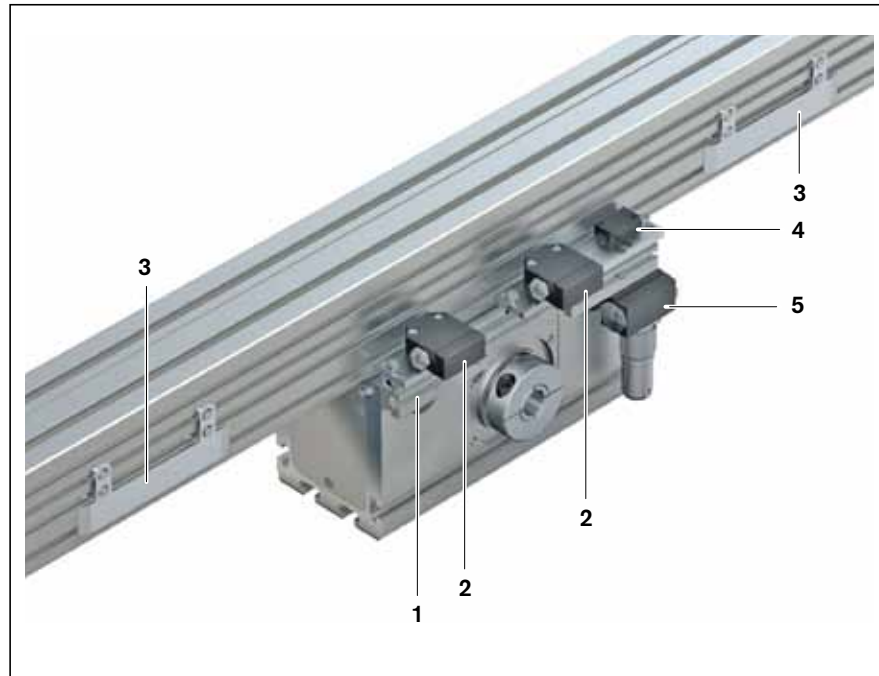

OBB 55

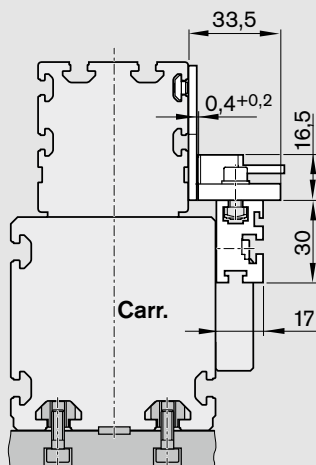

Proximity switches with mounting accessories

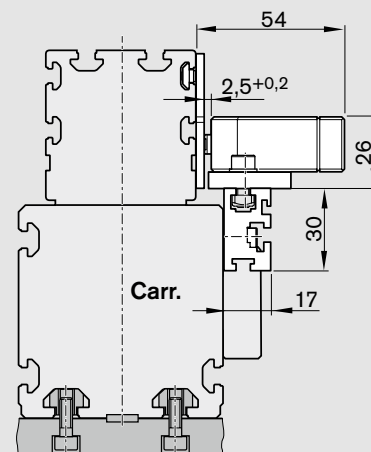

Mechanical switches with mounting accessories

OBB 85

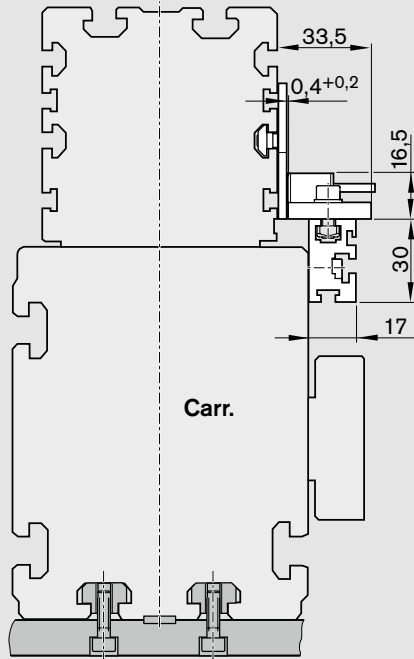

Proximity switches with mounting accessories

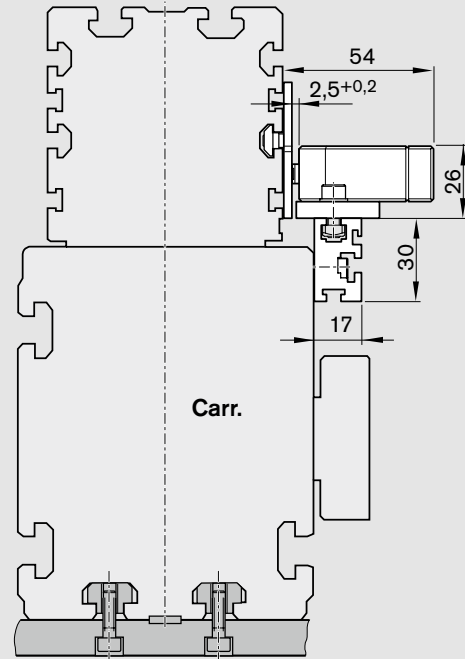

Mechanical switches with mounting accessories

OBB 120

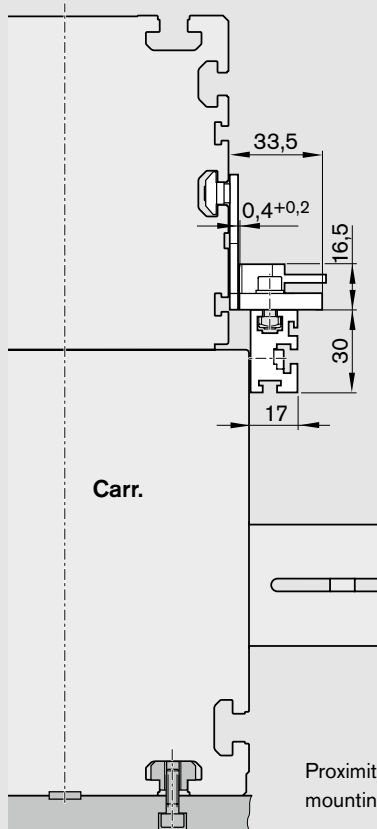

Proximity switches with mounting accessories

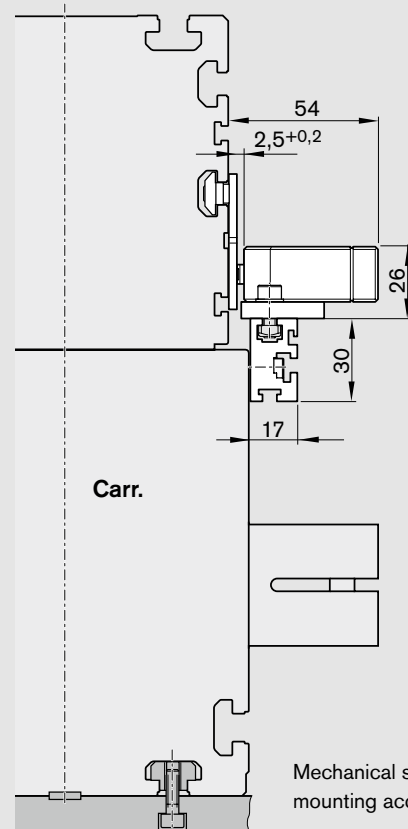

Mechanical switches with mounting accessories

EasyHandling Basic

Switch Mounting Arrangements – frame stationary, carriage travels

Switching principle

- Proximity or mechanical switches on the frame
- Switching via switching strip on the carriage (carr.)
- Similar to Linear Module series

Overview of switching system

- 1 Socket and plug
- 2 Switching strip
- 3 Mechanical switch (with mounting accessories)
- 4 Proximity switch (with mounting accessories)

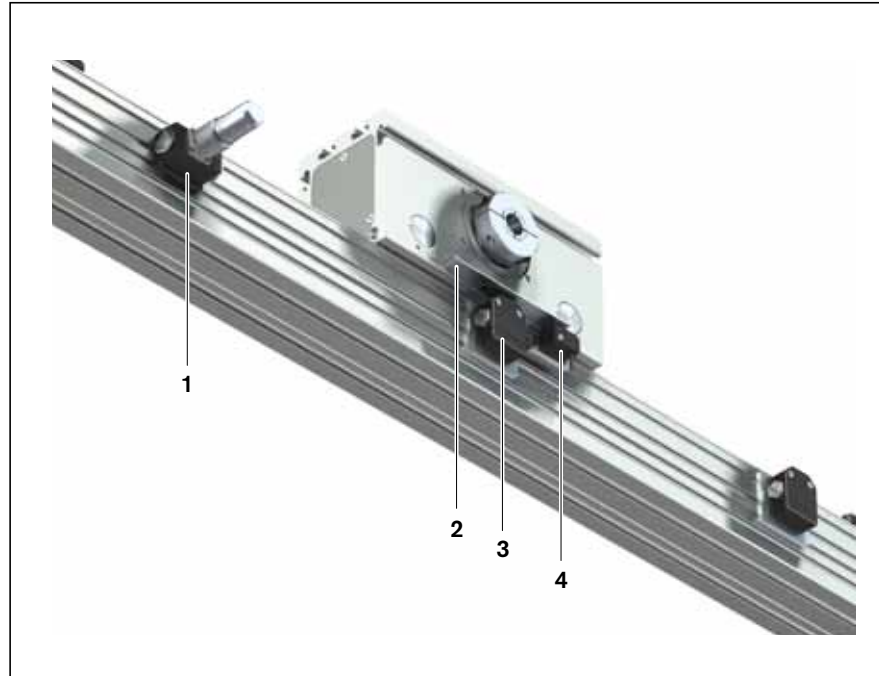

OBB 55

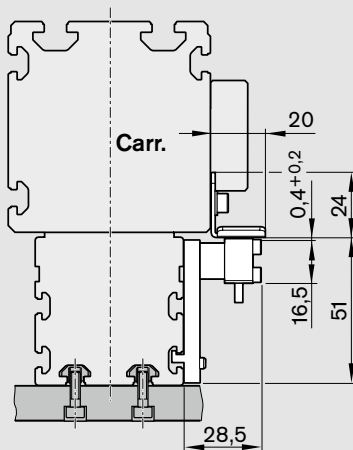

Proximity switches with mounting accessories

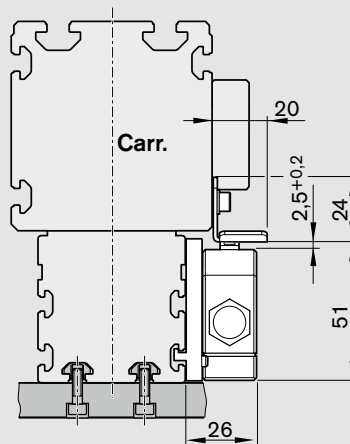

Mechanical switches with mounting accessories

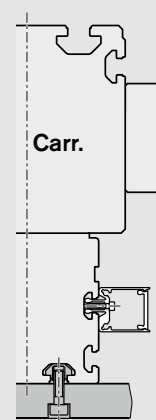

Cable duct

OBB 85

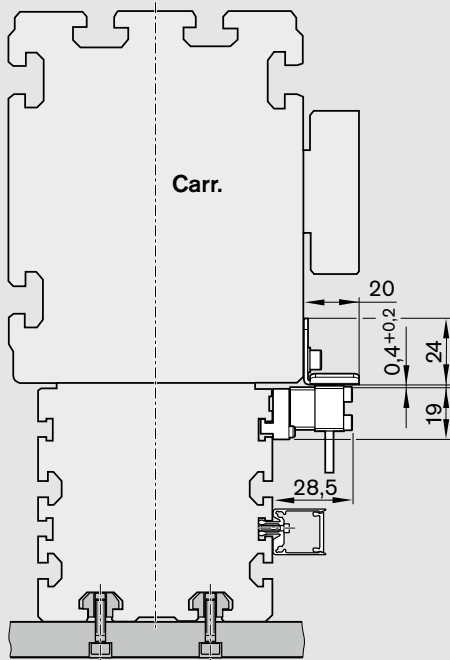

Proximity switches with mounting accessories / cable duct

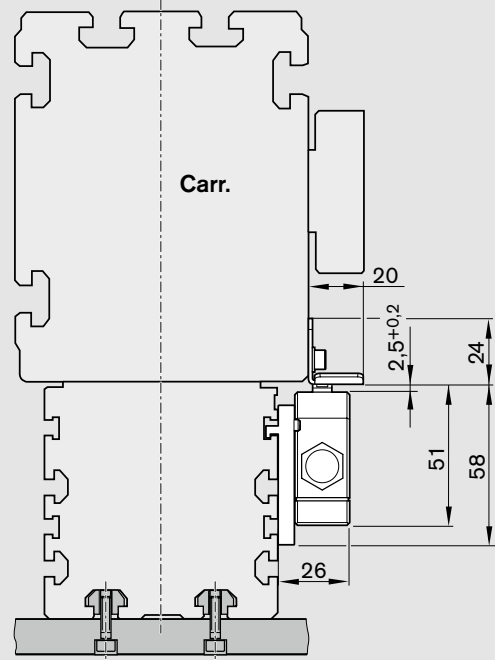

Mechanical switches with mounting accessories

OBB 120

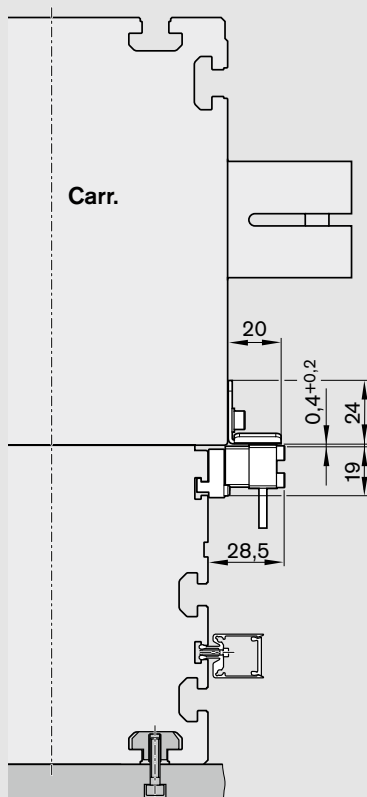

Proximity switches with mounting accessories / cable duct

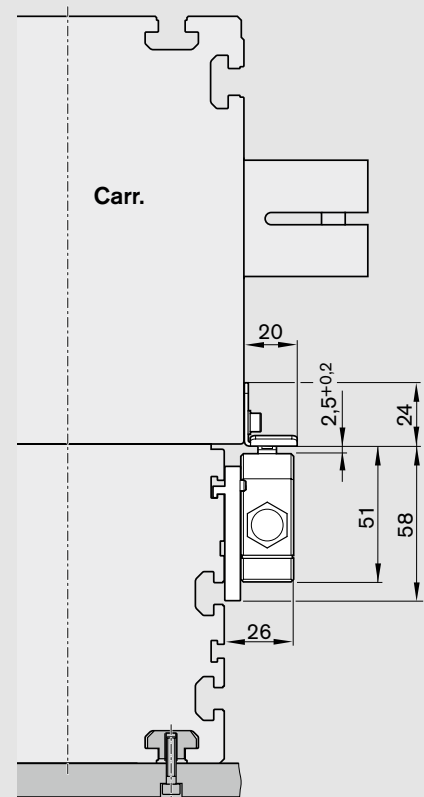

Mechanical switches with mounting accessories

EasyHandling Basic

Switches, Socket-Plug, Cable Duct

Switches

Mechanical switches

Mechanical switch	
Technical data	
Repeatability	± 0.05 mm
Permissible ambient temperature	-5 °C to $+80$ °C
Protection class	DIN 40050 IP 67
Bounce time	< 2 ms
Insulation class	Group C as per VDE 0110
Rated voltage	250 V AC
Continuous current	5 A
Switching capacity at 220 V, 40–60 Hz	$\cos\varphi = 0.8$ at 2 A
Contact resistance when new	< 240 m Ω
Connection type	Screw connector
Contact system	Single-pole changeover
Switching system	Snap-action
B _{10d} as per EN ISO 13849-1	1 000 000 switching cycles

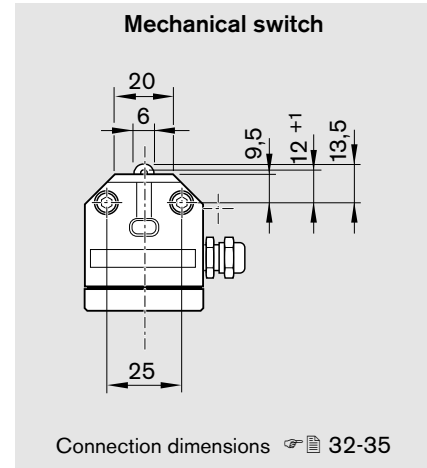

Proximity switches

Proximity switch with potted cable (3 x 0.14 mm ² Unitronic)	
Technical data	
Housing form	NO
Minisensor	Form A DIN 41635
Operating voltage	10 ... 30 V DC
Residual ripple	$\leq 10\%$
Load	200 mA
No-load current	≤ 20 mA
Switching frequency	max. 1500 Hz
Temperature-related shift in make point	≤ 4 $\mu\text{m}/\text{K}$
Output signal steepness	$\geq 1\text{V}/\mu\text{s}$
Repeatability of make point per EN 50008	≤ 0.1 mm
Cable length	3 m
MTTF _d as per EN ISO 13849-1	30 – 100 years

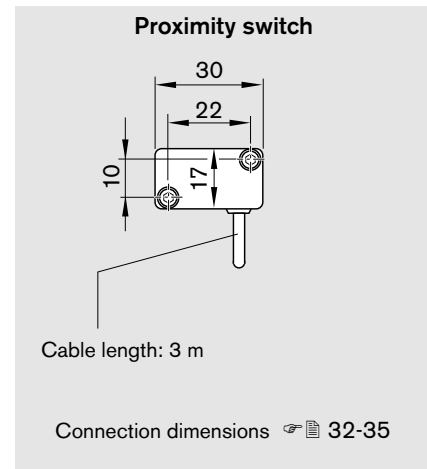

Socket-plug

Notes

The socket and plug have 16 pins.
The socket and plug are not pre-wired.

Since the mounting arrangements allow shifting of the switches, the switch activation points can be optimized during start-up.

A plug is provided.

The plug can be mounted in three directions.

- Attach the socket at the end with the most switches. (See example on next page.)

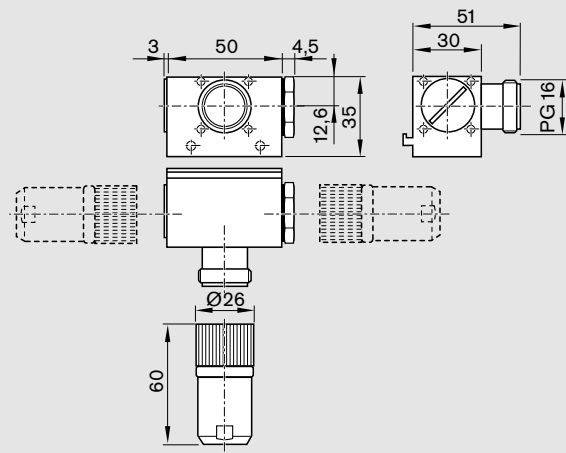

Cable duct

- The cable duct is fastened in the T-slots on the side of the frame. Fastening screws widen the profile and give the cable duct a secure hold.

For the slot position, see "Components and Ordering Data" tables and "Dimensions".

The cable duct will accommodate up to two cables for mechanical switches and three cables for proximity switches. Fastening screws and cable grommets are included.

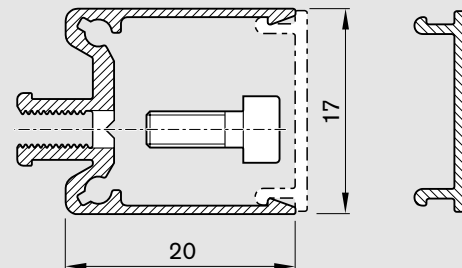

EasyHandling Basic

IndraDyn S Servo Motors

Notes

All MSK/MSM servo motors have an absolute multiturn encoder. The motors can be supplied complete with controller and control unit. For more information on motors, controllers and control systems, please refer to the Rexroth catalogs "IndraDrive Cs" and "Drive System Rexroth IndraDrive".

IndraDyn S Servo Motor MSK

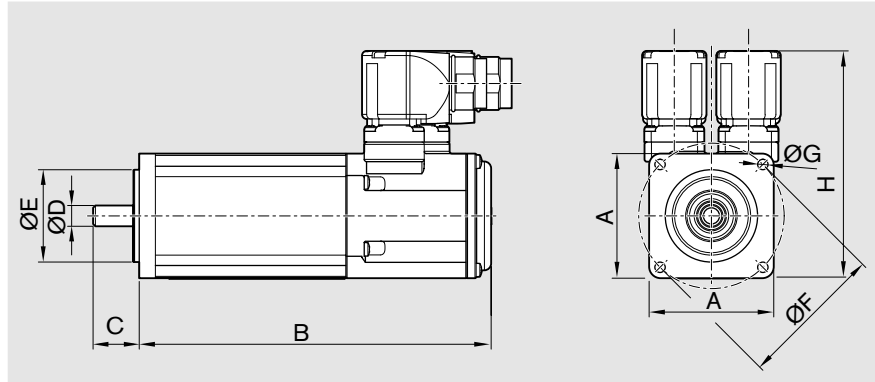

Motor		n_{\max} (min^{-1})	$M_{0\ 60K}$ (Nm)	M_{\max} (Nm)	I_0 (A)	I_{\max} (A)	J_m (kgm^2)	Mass ¹⁾ (kg)	Dimensions (mm)							
									A	B ¹⁾	C	ØD	ØE	ØF	ØG	H
MSK040	B-0450	6000	1.7	5.1	1.5	6	0.0001	2.8	82	155.5	30	14	50	95	6.6	124.5
	B-0600	7500	1.7	5.1	2	8	0.0001	2.8								
	C-0450	6000	2.7	8.1	2.4	9.6	0.00014	3.6	185.5							
	C-0600	7500	2.7	8.1	3.1	12.4	0.00014	3.6								
MSK050	B-0300	4300	3	9	1.8	7.2	0.00028	4.0	98	173	40	19	95	115	9	134.5
	B-0450	6000	3	9	2.8	11.2	0.00028	4.0								
	B-0600	6000	3	9	3.7	14.8	0.00028	4.0	203							
	C-0300	4700	5	15	3.1	12.4	0.00033	5.4								
	C-0450	6000	5	15	4.7	18.8	0.00033	5.4								
	C-0600	6000	5	15	6.2	24.8	0.00033	5.4								
MSK076	C-0300	4700	12	43.5	7.2	32.4	0.0043	13.8	140	292.5	50	24	110	165	11	180.0
	C-0450	5000	12	43.5	12.2	54.9	0.0043	13.8								

1) Without holding brake

n_{\max} = maximum motor speed

$M_{0\ 60K}$ = continuous torque at standstill

M_{\max} = maximum torque

I_0 = continuous current at standstill

I_{\max} = maximum current

J_m = mass moment of inertia

Motor	Part number	Type designation	
		Without holding brake	Without holding brake
MSK040	B-0450	R911316887	MSK040B-0450-NN-M1-UG0-NNNN
	B-0600	R911306058	MSK040B-0600-NN-M1-UG0-NNNN
	C-0450	R911320143	MSK040C-0450-NN-M1-UG0-NNNN
	C-0600	R911306060	MSK040C-0600-NN-M1-UG0-NNNN
MSK050	B-0300	R911308506	MSK050B-0300-NN-M1-UG0-NNNN
	B-0450	R911326097	MSK050B-0450-NN-M1-UG0-NNNN
	B-0600	R911299935	MSK050B-0600-NN-M1-UG0-NNNN
	C-0300	R911307944	MSK050C-0300-NN-M1-UG0-NNNN
	C-0450	R911316880	MSK050C-0450-NN-M1-UG0-NNNN
	C-0600	R911298354	MSK050C-0600-NN-M1-UG0-NNNN
MSK076	C-0300	R911314849	MSK076C-0300-NN-M1-UG0-NNNN
	C-0450	R911318098	MSK076C-0450-NN-M1-UG0-NNNN

IndraDyn S Servo Motor MSM

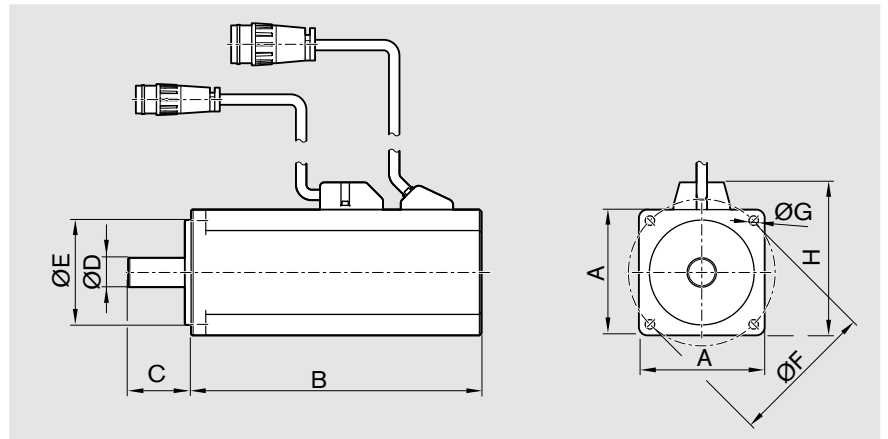

Motor	n_{\max} (min^{-1})	M_0 (Nm)	M_{\max} (Nm)	P_N (W)	Mass ¹⁾ (kg)	Dimensions (mm)							
						A	B ¹⁾	C	ØD	ØE	ØF	ØG	H
MSM 031C	5000	1.3	3.8	400	1.2/1.7	60	98.5/135	30	14	50	70	4.5	73
MSM 041B	4500	2.4	7.1	750	2.3/3.1	80	112/149	35	19	70	90	6	93

1) Without/with holding brake

n_{\max} = maximum motor speed
 $M_{0\ 60K}$ = continuous torque at standstill
 M_{\max} = maximum torque
 P_N = continuous power

Motor	Part number	Part number		Type designation	
		Without holding brake	With holding brake	Without holding brake	With holding brake
MSM 031C	0300	R911325139	R911325140	MSM 031C-0300-NN-M0-CH0	MSM 031C-0300-NN-M0-CH1
MSM 041B	0300	R911325143	R911325144	MSM 041B-0300-NN-M0-CH0	MSM 041B-0300-NN-M0-CH1

EasyHandling Basic

Mounting

General notes

The Omega Modules are mounted using various mounting components:

- Clamping fixtures
- Sliding blocks
- Square nuts
- Screws for T-slots as per DIN 787 (not shown)

- Centering rings on carriage as positioning aids

Length dependent on base.

When mounting Omega Modules, please note the maximum tightening torques listed in the table.

Mounting by the carriage (frame travels)

OBB	A (mm)	B (mm)	C (mm)	D (mm)
55	91	105	40	50
85	130	148	40	80
120	157	175	80	100

Mounting by the carriage (carr.) (frame travels)

Fastening with clamping fixtures

Fastening with sliding blocks

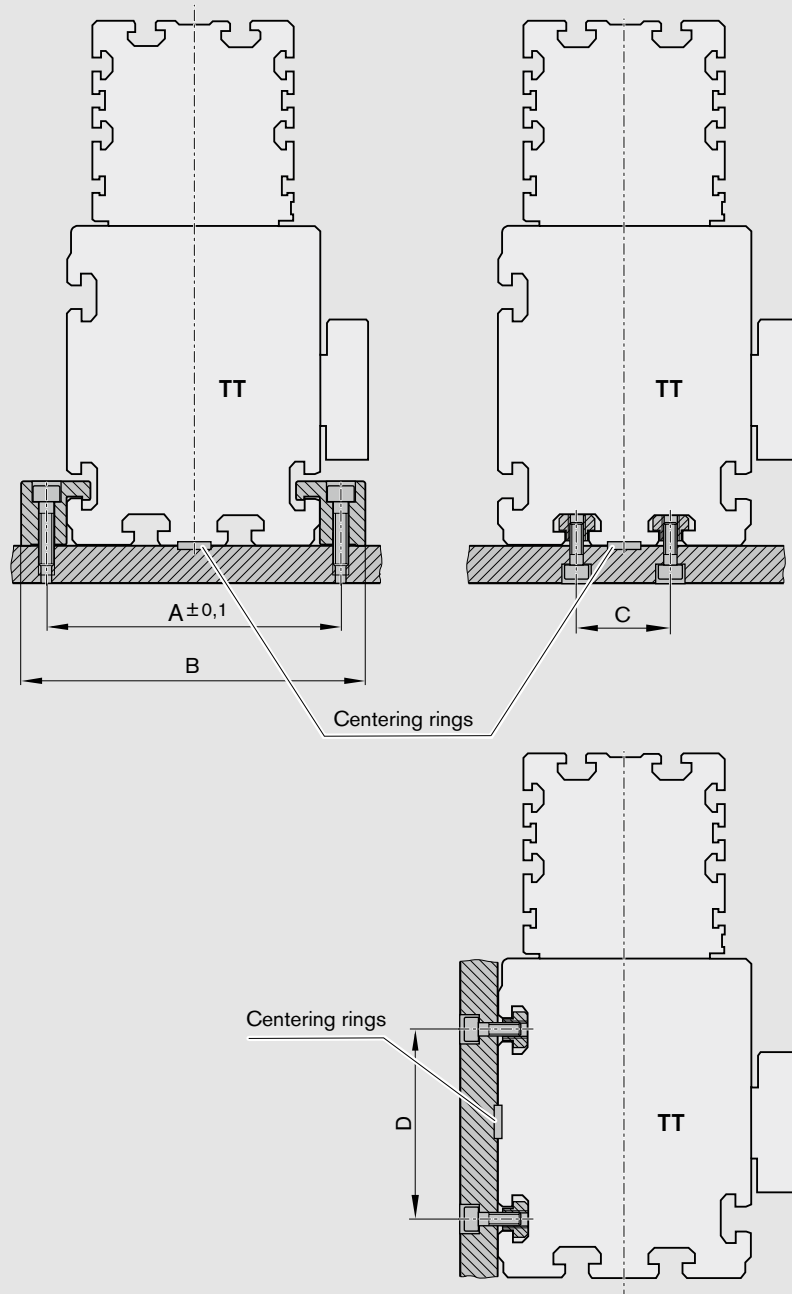

Mounting by the frame (carriage travels)

**⚠ Do not fix the Omega Module at the end plates!
The frame is the main load-bearing part!**

OBB	A (mm)	B (mm)	C (mm)
55	71	85	25
85	101	115	40
120	144	162	80

Mounting by the frame (carriage/drive travels)

Fastening with clamping fixtures

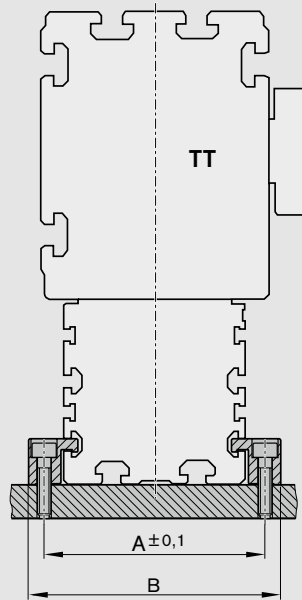

Fastening with sliding blocks

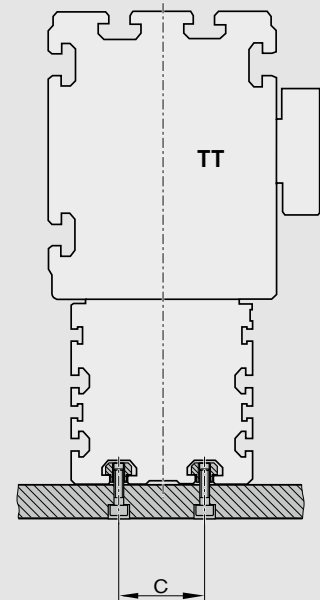

EasyHandling Basic

Mounting

Clamping fixtures

Recommended number of clamping fixtures for carriage:

- Type 2: 3 pieces on side opposite motor
- Type 2: 2 pieces on motor side

Recommended number of clamping fixtures for frame:

- Type 2: 4 pieces per side/m

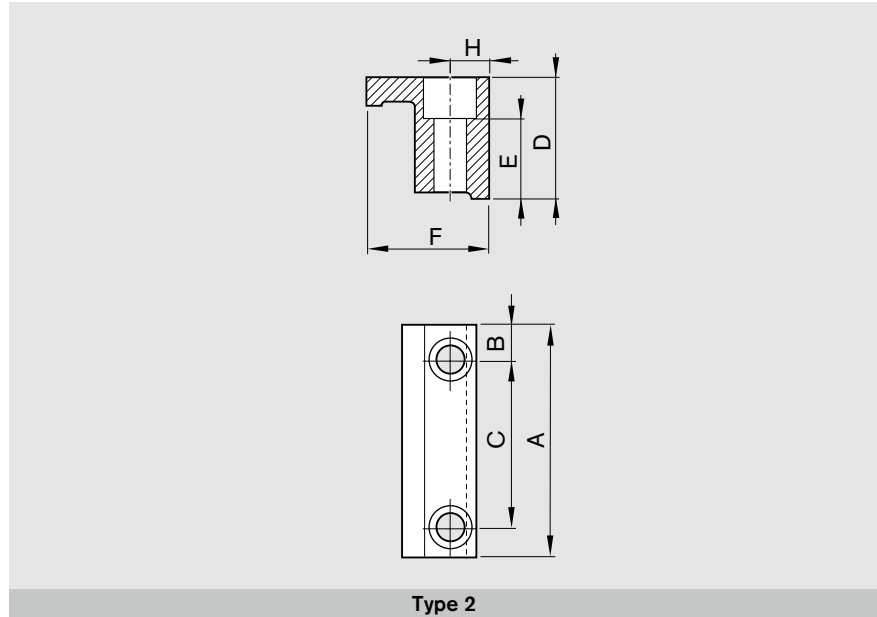

OBB	Mounting	Countersink ISO 4762 for	Type	Number of holes N	Dimensions (mm)							Part number
					A	B	C	D	E	F	H	
55	Carriage	M6	2	2	65	12.5	40	17.0	10.2	21	7	R1175 192 04
	Frame	M6	2	2	72	11	50	11.5	5.3	19.3	7	R0375 510 33
85	Carriage	M8	2	2	68	15	38	27.5	18.0	30	9	R0375 410 52
	Frame	M6	2	2	78	14	50	20.0	11.3	21	7	R1175 390 30
120	Carriage	M8	2	2	88	19	50	27.5	18.0	30	9	R0375 410 50
	Frame	M8	2	2	108	19	70	27.5	16.3	29	9	R1175 290 26

Centering rings

The centering ring serves as a positioning aid. It creates a positive-locking connection with good reproducibility.

Material: steel (corrosion-resistant)

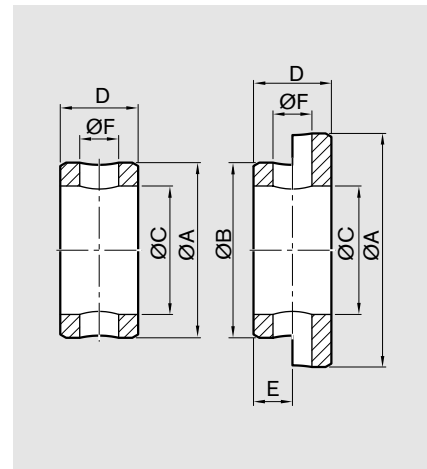

OBB	Centering ring size	Part number	Dimensions (mm)						
			A	B	C	D	E	ØF	
55	12-7	R0396 605 77	12	7	±0.1	-0.2	+0.2	1.6	
85, 120	16-12	R0396 605 51	16	12	9.0	5.0	2.0	2.0	

Sliding blocks and springs

The spring serves as a mounting and positioning aid.

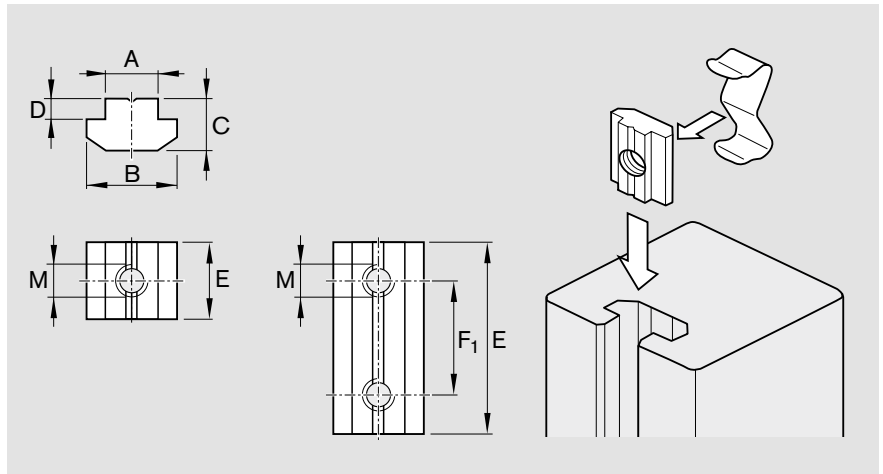

Sliding blocks for lateral mounting on frame

OBB	A (mm)	E (mm)	G (mm)
55	5	10	12
85	6	12	14
120	8	16	18

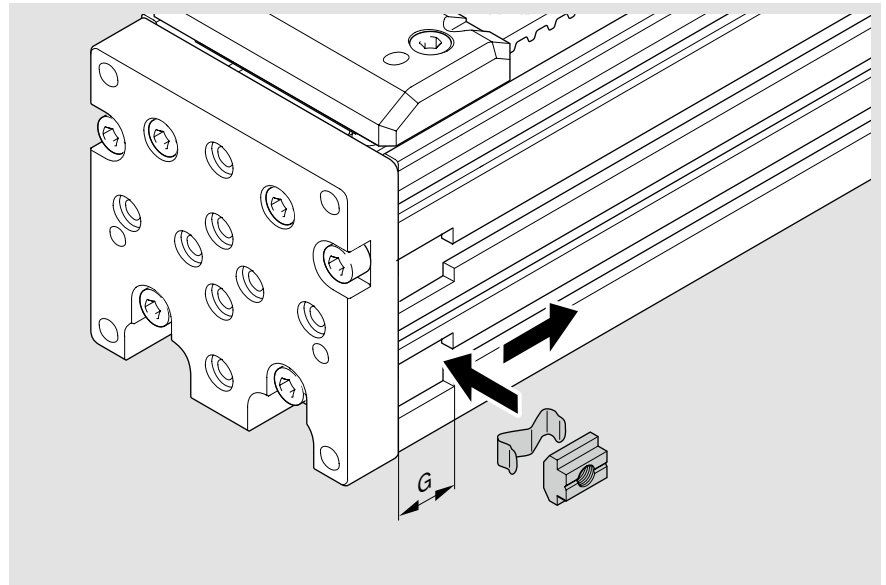

Dimensions (mm)						for thread	Part number Sliding block	Part number Spring
A	B	C	D	E	F ₁			
5	9.2	4	1.7	10	-	M4	R0391 710 38	-
6	11.5	4	1	12	-	M4	R3447 014 01	R3412 010 02
				12	-	M5	R3447 015 01	R3412 010 02
				45	30	M5	R0391 710 09	-
8	16.0	6	2	16	-	M4	R3447 017 01	R3412 011 02
				16	-	M5	R3447 018 01	R3412 011 02
				16	-	M6	R3447 019 01	R3412 011 02
				16	-	M8	R3447 020 01	R3412 011 02
				50	36	M6	R0391 710 08	-
10	19.5	10.5	5	20	-	M4	R3447 012 01	R3412 009 02
				20	-	M5	R3447 011 01	R3412 009 02
				20	-	M6	R3447 010 01	R3412 009 02
				20	-	M8	R3447 009 01	R3412 009 02
				90	70	M8	R0391 710 07	-

EasyHandling Basic

Carriage with Clamping Unit

Carriage with clamping unit

Pressureless clamping (spring energy)

- Release pressure min. 5.5 bar
- Max. pneumatic operating pressure: 8 bar

Notes

For carriages with integrated clamping unit there is a standard air port (1) at each end of the carriage opposite the lube nipples. One air port per side is sufficient.

- Use only filtered and lubricated air.
The filter mesh size is approx. 25 µm.
- Read the mounting instructions before start-up.

⚠ The unit may not be used as a braking unit! Use only when the axis is at a standstill!

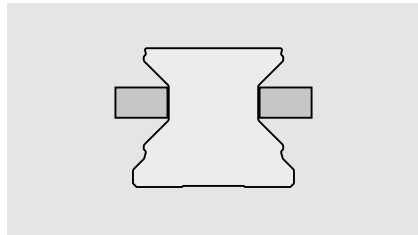
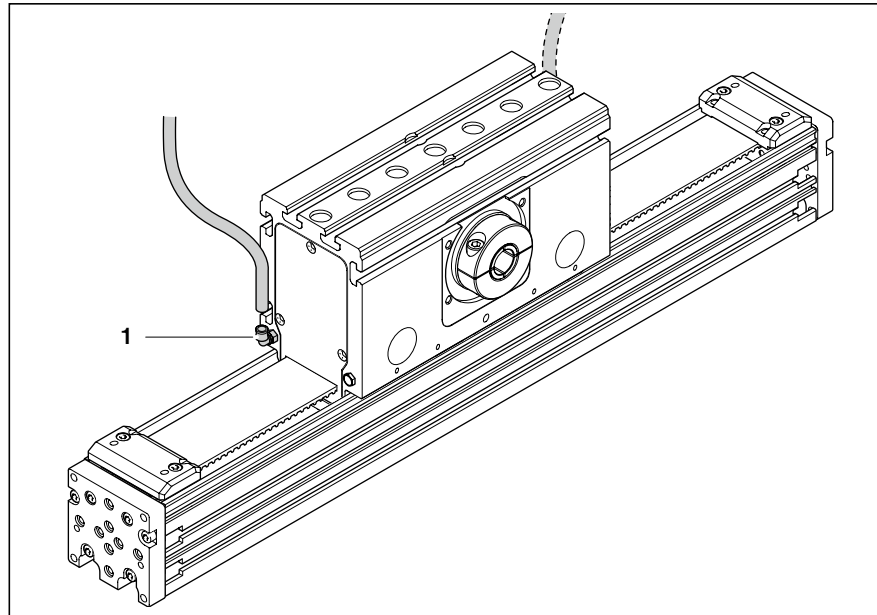

Air pressure: 0 bar

Clamping by spring action

When the pressure drops, the clamping profiles are pressed against the guide rail by means of a spring energy accumulator. A quick venting valve is required for fast response.

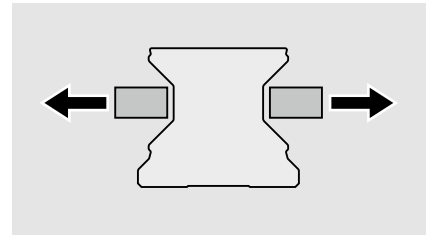

Air pressure: 5.5 - 8 bar

Release by air pressure

The clamping profiles are held apart by compressed air.

- Allows free movement

OBB	Holding force Spring energy ¹⁾ (N)	Plug connection for hose diameter (mm)
55	370	Ø4
85	690	Ø4
120	1 200	Ø4

1) Testing is performed in the installed condition with a film of lubricating oil (ISO VG 68).

Attachment of Add-on Modules

End plate for attachment

The end plates of the Omega Modules feature mounting holes, threads and locating holes for attachment of add-on modules (e.g. Mini Slides, Grippers, etc.).

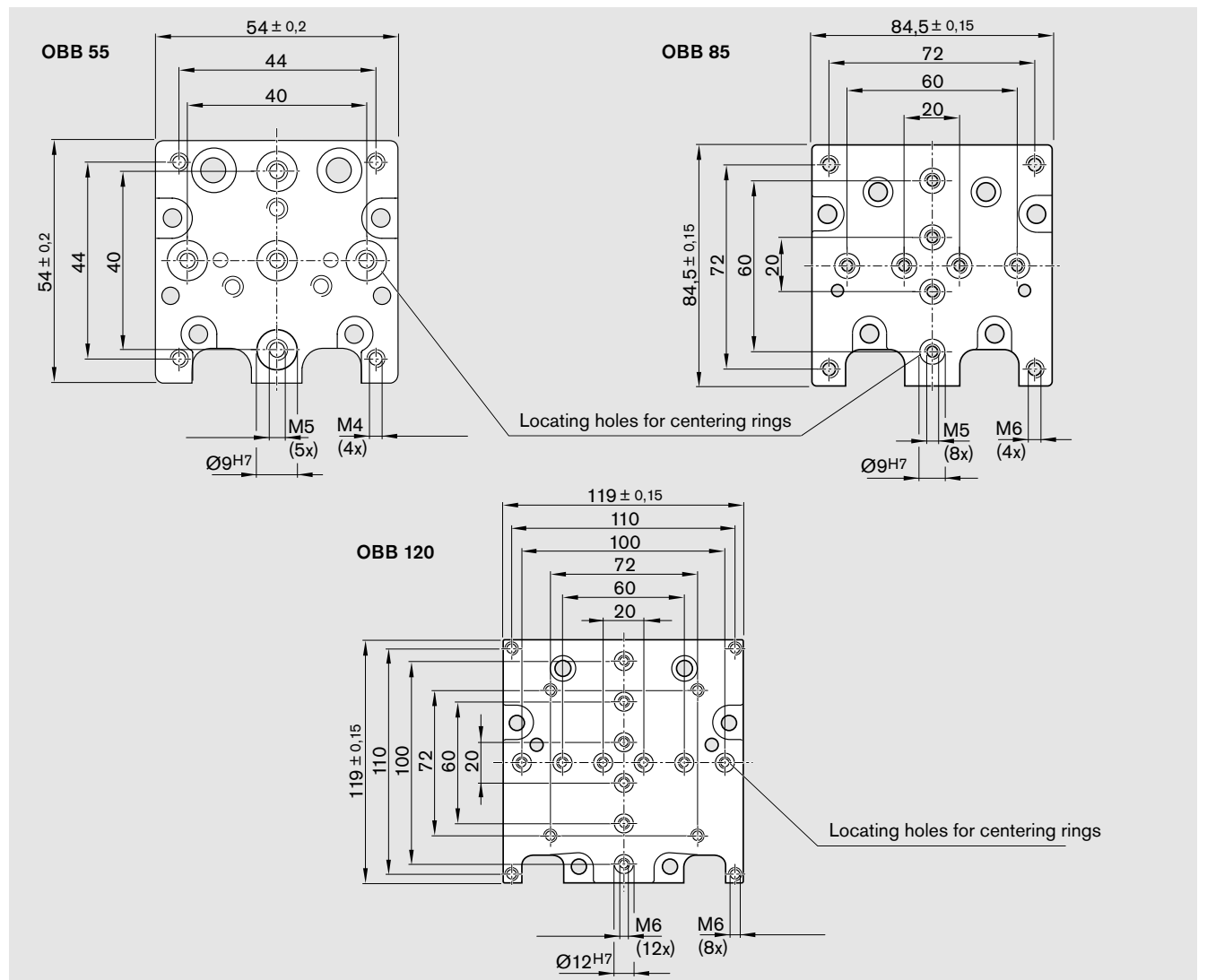
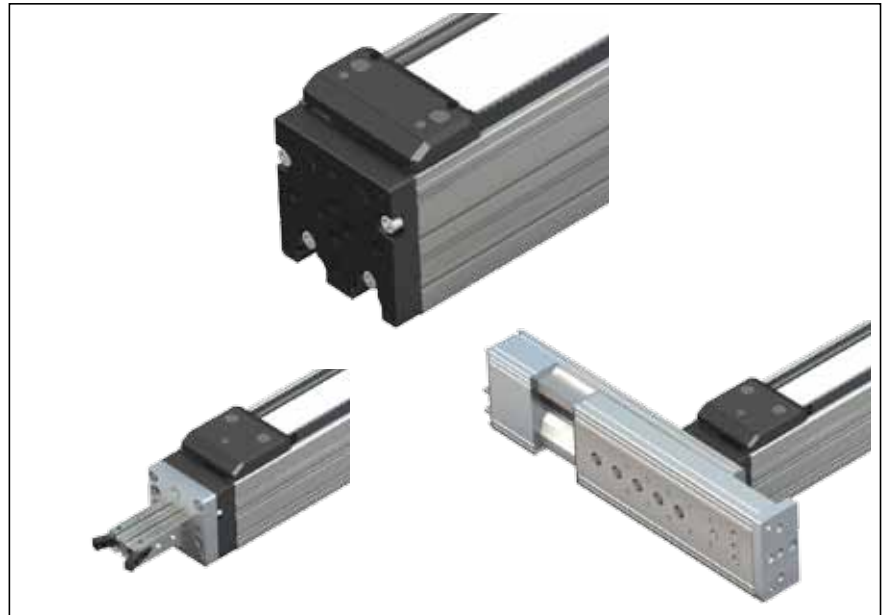

EasyHandling Basic

Accessories

Shock absorbers

Suitable shock absorbers are available for end position cushioning of the Omega Modules.

The shock absorber serves to avoid damage in the event of uncontrolled movements. It is not intended for continuous operation.

Notes

Follow the mounting instructions.

Shortened stroke

⚠ The stroke is shortened when shock absorbers are installed.

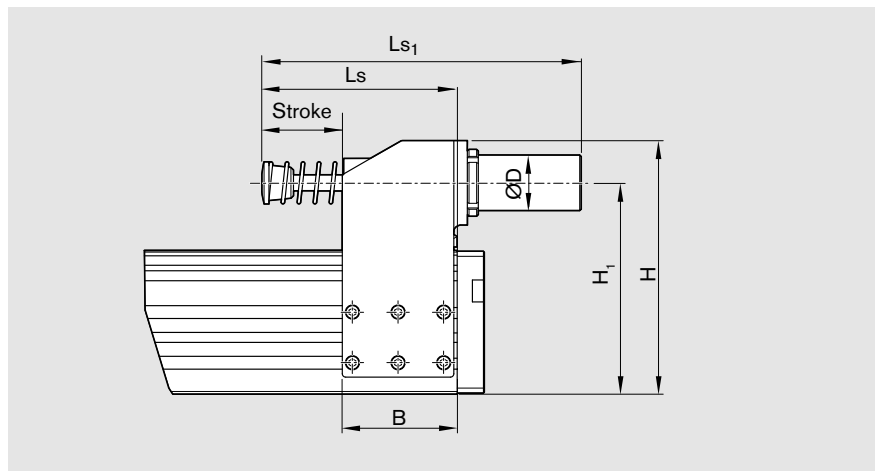
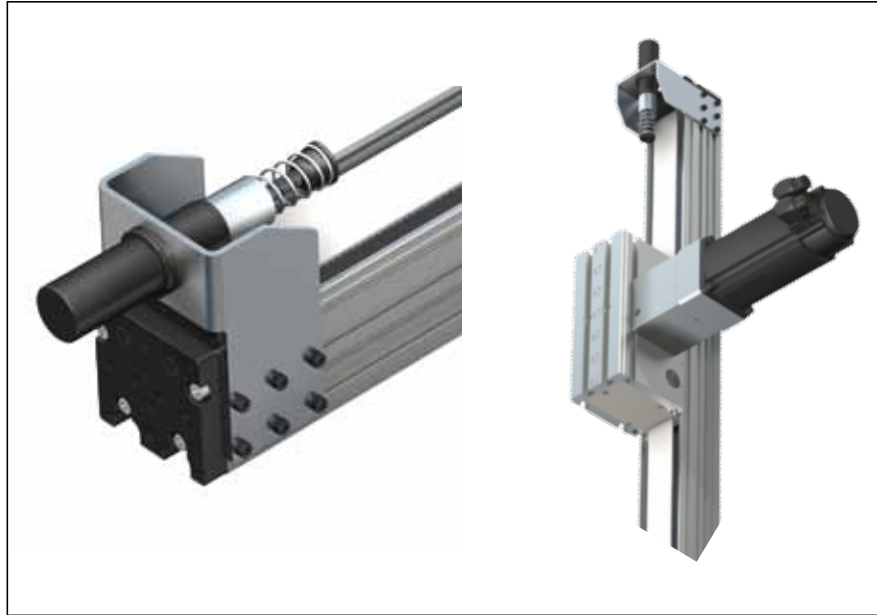

Mounting bracket

OBB	Part number	Dimensions (mm)								
		B	H	H ₁	L _S	L _S (with clamping unit)	L _{S1}	Stroke	Ø D	
55	R1175 101 17	56.5	113	90.5	105	123	189	50	M33 x 1.5	
85	R1175 301 17	68.0	150	125.0	115	133	189	50	M33 x 1.5	
120	R1175 601 17	99.0	210	210.0	172	190	246	75	M45 x 1.5	

Shock absorbers

OBB	Energy absorption (Nm/stroke)	Service life (cycles)	Shortened stroke, min. (mm)	Weight (Mounting bracket and shock absorber) (kg)
55	620	max. 1000	50	0.95
85	950	max. 5	55	1.35
120	2040	max. 1000	95	4.00

Cable drag chains

Special mounting elements are available for mounting cable drag chains to Omega Modules.

The assembly kit consists of:

- 1 Mounting profile for the carriage, with screws and sliding blocks
- 2 Mounting profile for the frame, with clamping plate and set screws

Additional parts (not included in kit):

- 3 Mounting profile for cable drag chain
- 4 Cable drag chain (for information, see the following pages)

Notes for mounting

Follow the mounting instructions.

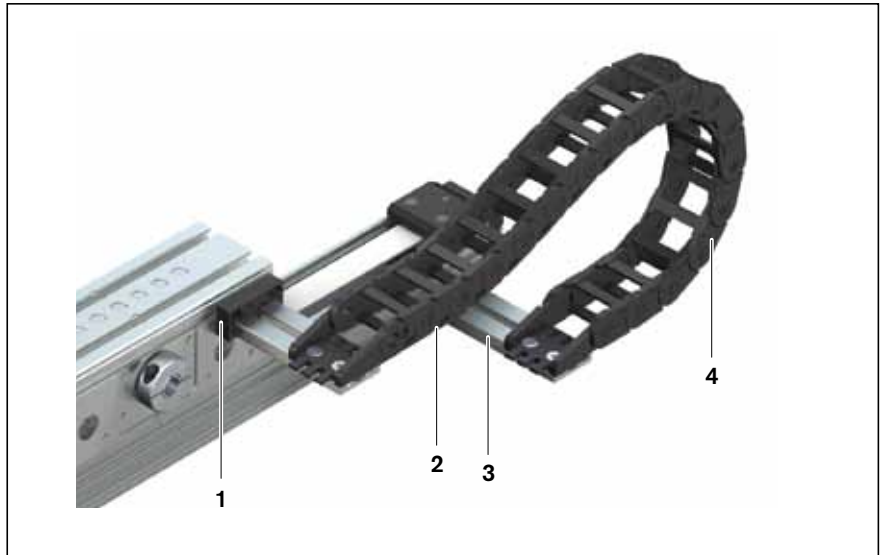

Mounting profile (1) for carriage

OBB	Part number
55	R0391 700 32
85, 120	R0391 700 45

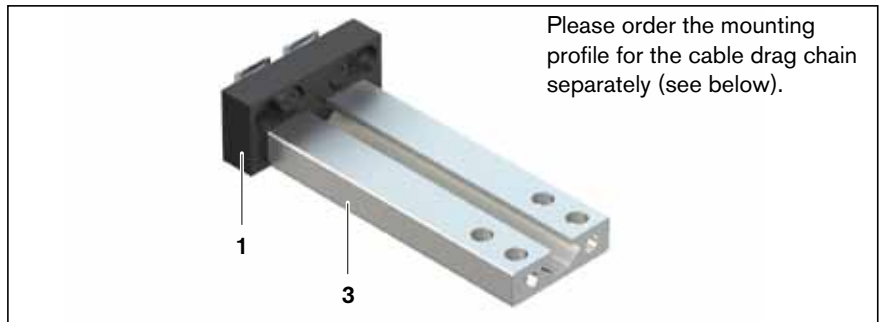

Mounting profile (2) for frame

OBB	Part number
55, 85, 120	R0391 700 15

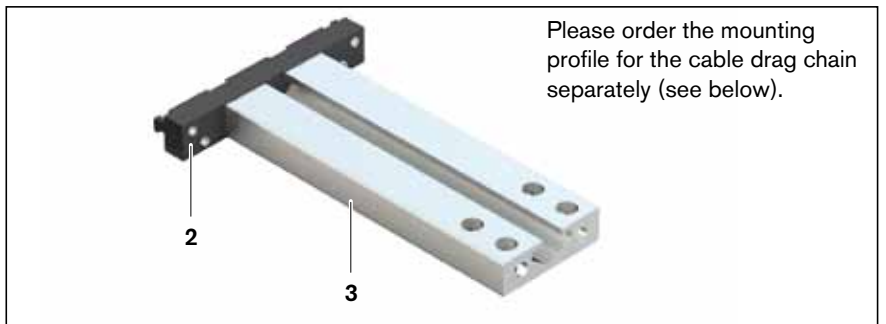

Mounting profile (3) for cable drag chain

Consisting of:

- Profile (1x)
- M6 socket head cap screw (2x)
- M6 sliding block (2x)
- Screw DIN 7500 M5x25 (2x)

Profile (mm)	Length (mm)	Part number
12x40	200	R0391 700 12
	Variable	R0391 700 13

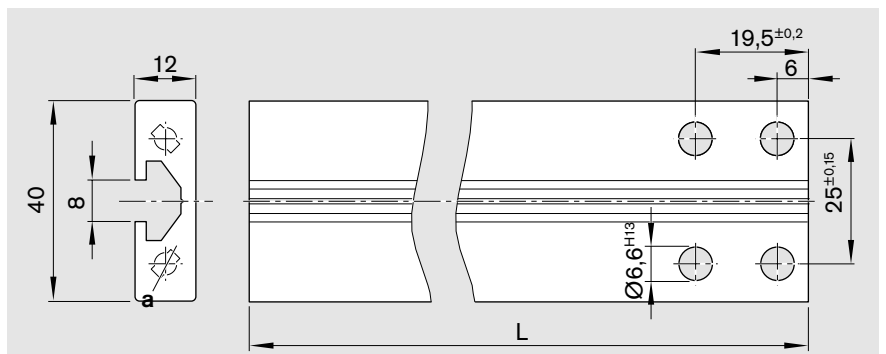

a) For M5 self-tapping screws

EasyHandling Basic

Accessories

Cable drag chains System MP3000

Pitch 45 mm

Separators are installed at every second link.

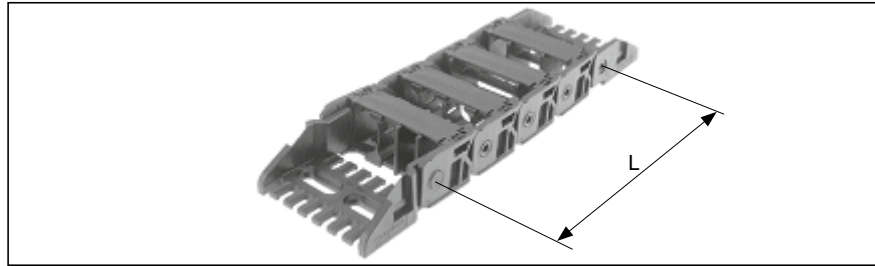

L = multiple of 45 mm pitch

Ordering data: R0391 700 04,
990 mm (22 links of 45 mm each)

Cable drag chain Type	Width B (mm)	Inside dimensions b x h (mm)	Part number	No. of separators Every 2nd link	Radius R (mm)
ESD-MP3002	55	37 x 26	R0391 700 03	1	70
ESD-MP3003	80	62 x 26	R0391 700 04	2	70
ESD-MP3003	80	62 x 26	R0391 700 40	3	95
ESD-MP3005	119	101 x 26	R0391 700 05	3	70

Dimensions of chain link

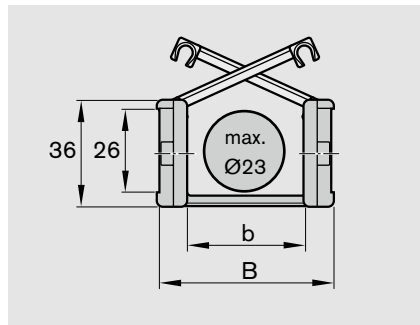

Technical specifications

Travel distance, gliding	L_g	60 m
Travel distance, self-supporting	L_f	See graph
Travel distance, vertical, hanging	L_{vh}	40 m
Travel distance, vertical, upright	L_{vs}	3 m
Rotated 90°, unsupported	L_{90f}	0.7 m
Speed, gliding	V_g	3 m/s
Speed, unsupported	V_f	6 m/s
Acceleration, gliding	a_g	10 m/s ²
Acceleration, unsupported	a_f	15 m/s ²

Loading side: inside flexure curve

Separator

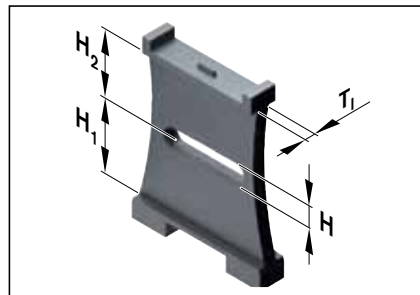

Type	Dimensions (mm)			
	T_1	H	H_1	H_2
TR 3000 / TR 3001	1.5	2.5	12.9	12.9

Mounting dimensions

Dimensions (mm)			
Radius	R	70	95
Outside height of chain line	H_G	35	35
Height of bend	H	175	225
Height of moving end connection	H_{MA}	140	190
Safety margin with bias	S_V	45	45
Installation height with bias	H_{SV}	220	270
Safety margin without bias	S_K	10	10
Installation height without bias	H_{SK}	185	235
Arc projection	M_L	133	157.5
Bend length	L_B	320	398

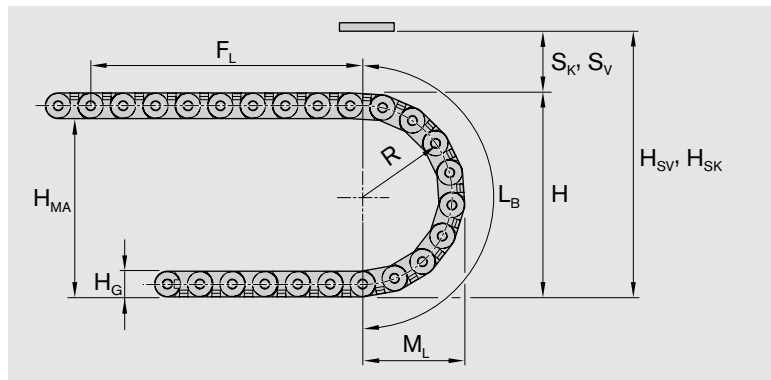

Chain bracket

(delivered along with the cable drag chain)

Consisting of:

- 1 piece with hole
- 1 piece with pin
- Screws and sliding blocks

- The chain brackets must be fastened using the delivered screws.

The cables or hoses must be fixed to the chain bracket's integrated strain relief using cable binders.

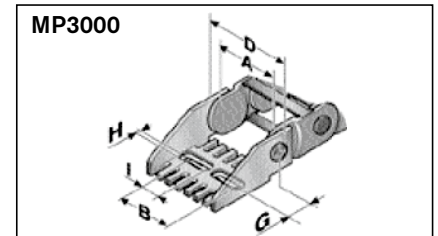

Chain type	Chain bracket type	Dimensions (mm)						
		A	B	D	F	G	H	I
MP3002	KA/Z 3002	37.0	30	55	-	31.5	Ø 6.5	7.5
MP3003	KA/Z 3003	62.0	62	80	-	31.5	Ø 6.5	18.5
MP3005	KA/Z 3005	101.0	94	119	-	31.5	Ø 6.5	18.5

EasyHandling Basic

Accessories

Cable drag chains Technical data Unsupported length

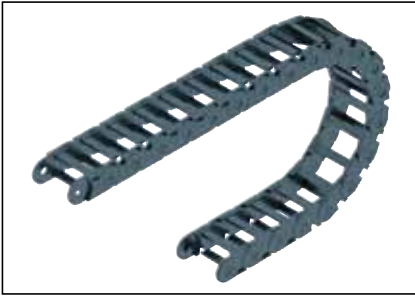

F_{Lg}:
Ideal installation situation for high stresses at the limit of the max. travel parameters. In this range the chain upper run is still biased, straight or has a max. sag of 10 – 50 mm depending on the type of chain.

F_{Lb}:
Satisfactory installation position for many applications working in the lower to middle range of the max. travel parameters. Depending on the chain type, the sag of the chain upper run is > 10 – 50 mm but less than the max. sag. If the sag is greater than F_{Lb}, the arrangement is unsuitable and should be avoided. Please choose a more stable cable drag chain.

Determining the chain length

The fixed point of the cable drag chain should be connected in the middle of the travel distance. This arrangement gives the shortest connection between the fixed point and the moving consumer and thus the most efficient chain length.

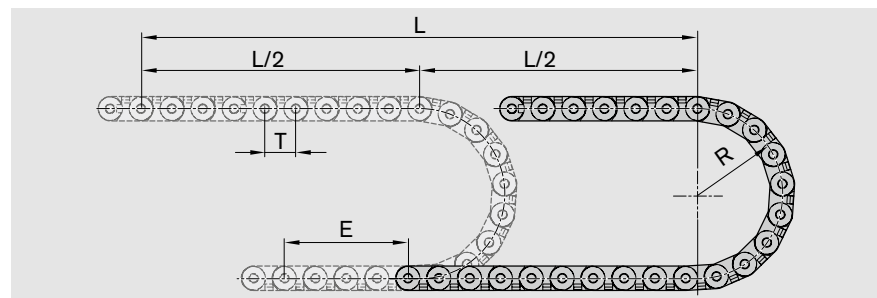
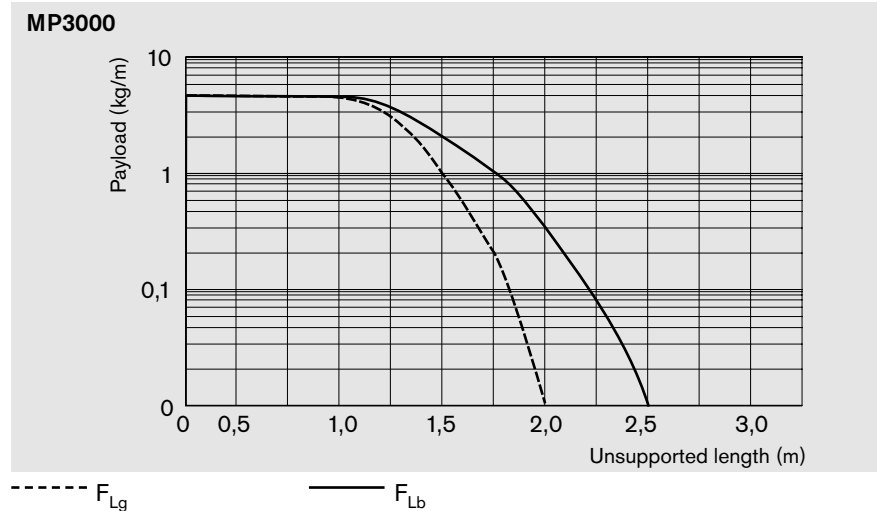

$$L_{ch} = \frac{L}{2} + \pi \cdot R + 2 \cdot T + E$$

L_{ch} = chain length (mm)
L = travel distance (mm)
R = radius (mm)
T = pitch (mm)
E = distance between entry point and middle of travel distance (mm)

MP3000: ~ 1 m chain: 22 links of 45 mm each

Guide channels for cable drag chains

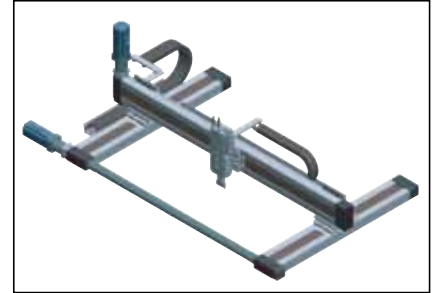

The guide channels are matched to the cable drag chains. For short travel distances they serve as a support for stacking the links and for long travel distances they also serve as guides. To minimize chain wear, stainless steel sheet was chosen as the material for the guide channels.

The mounting holes for the chain bracket are already integrated in the guide channel. The guide channel has holes drilled at 500 mm intervals along the centerline for M5 countersunk screws.

It comes complete with the necessary countersunk screws and sliding blocks.

Dimensions

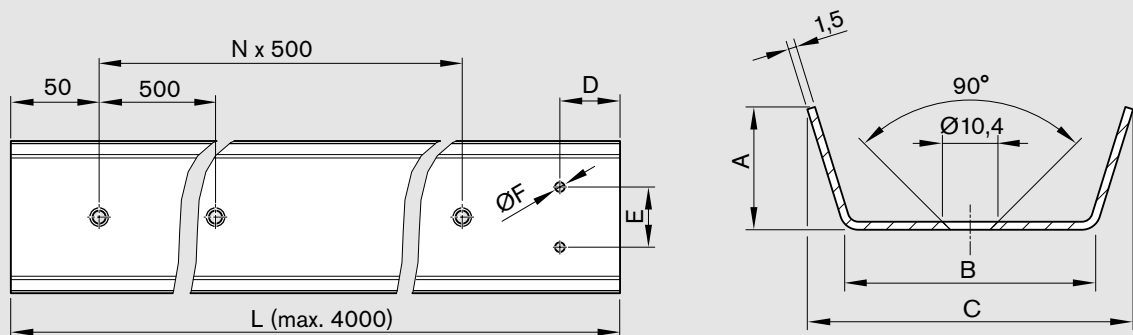

Chain type	Guide channel	Dimensions (mm)						Part number
		A	B	C	D	E	F	
MP3002	Chain guide MP3002	35	70	84	12.5	25	Ø 6.6	R0391 700 09
MP3003	Chain guide MP3003	35	95	109	12.5	45	Ø 6.6	R0391 700 10
MP3005	Chain guide MP3005	35	134	148	12.5	85	Ø 6.6	R0391 700 11

EasyHandling Comfort

Motor-Controller Combination

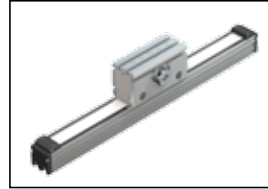

A choice can be made between several different motor/controller combinations to achieve the most cost-effective solution for each customer application. When sizing the drive, always consider the motor-controller combination.

For further information, see "Drive System Rexroth IndraDrive" catalog R911311519.

IndraDyn S servo motor MSK

IndraDyn S servo motor MSM

IndraDrive Cs
compact drive system with multiple protocol capability
Compact and dynamic solution
for lower power ranges

Omega Modules can be supplied complete with motor, controller and control unit.

Motor-controller combination
(recommended)

Motor	Controller
MSK040	HCS 01.1E-W0018
MSK050	HCS 01.1E-W0018
MSK076	HCS 01.1E-W0028
MSM031C-0300	HCS 01.1E-W0009
MSM041B-0300	HCS 01.1E-W0013

Safety on Board – integrated, certified and consistent

Whatever branch of industry you call your own, the protection of man, machine and tool has absolute priority!

Modern safety concepts are needed to meet the most exacting requirements such as “Safe Motion”, “Safe Processing of Peripheral Signals” and “Safe Communication”. Safety on Board by Rexroth satisfies all these requirements and is synonymous with intelligent and well thought-out safety solutions.

**SAFETY
ON
BOARD**

SafeMotion

the drive-based safety solution from Rexroth, means much more than just the “safe stop” of machinery. In fact, SafeMotion is the first step in the realization of safe machine concepts.

It allows the operator to have access to the process without danger, increases availability by reducing downtimes and therefore increases productivity.



Safety on Board: functional safety from Control City – your control technology capital.

Integrated

Maximum protection for personnel, reduced idle times, increased availability and simplified start-up and validation – these are just some of the advantages of integrated safety technology from Rexroth. By integrating safety functions in standard components, we upgrade them to full-fledged safety components. These can be used as stand-alone units or as part of our system solutions.

Certified

Safety on Board provides the machine manufacturer with a guarantee of maximum safety and reliability, on the basis of components and system solutions which are tested and certified in accordance with the latest safety standards. This minimizes the cost and effort involved in the validation of plant and machinery and gives the manufacturer assurance – both in functional and legal terms.



Safety on Board – from the drive to the control system, Rexroth offers safety solutions that can be optimally scaled.

Further Information

Maintenance

Normal operating conditions

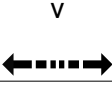
Ambient temperature Temperature must not fall below dew point	0 °C ... 40 °C	
Load	See technical data	
Travel speed	3 m/s	
Travel	> 150 mm	
Contamination	Not permitted	

Design notes

 **Moved parts:
Safety devices and guards necessary**

 **For vertical installations:
Arresting devices necessary to protect against falling loads**

Intended use

The product is an assembly.

The product may be used in accordance with the technical documentation (product catalog) for the following purposes:

- for precise positioning in space.

The product is intended exclusively for professional use and not for private use. Use for the intended purpose also includes the requirement that you must have read and understood the product documentation completely, in particular these “Safety instructions”.

The product is exclusively intended for incorporation into a final machine or a system or for assembly to other components for the purpose of building a final machine or a system.

Misuse

Use of the product in any other way than as described under “Intended use” is considered to be misuse and is therefore not permitted. If unsuitable products are installed or used in safety-relevant applications, this may lead to uncontrolled operating statuses in the application which can cause personal injury and/or damage to property.

The product may only be used in safety-relevant applications if this use has been expressly specified in the product documentation and is permitted, e.g. in zones with potentially explosive atmospheres or in safety-critical parts of a control system (functional safety).

Bosch Rexroth AG will not accept any liability for injury or damage caused by misuse of the product. The risks associated with any misuse of the product shall be borne by the user alone. Misuse of the product includes:

- the transport of persons

Lubrication

Lubrication notes

Basic lubrication is applied in-factory before shipment. Omega Modules have been designed for lubrication with grease using a grease gun. The only maintenance required is re-lubrication of the integrated Ball Rail System via one of the two funnel-type lube nipples (1).

Lubrication point

- 1 Funnel-type lube nipple DIN 3405-D3 for runner blocks

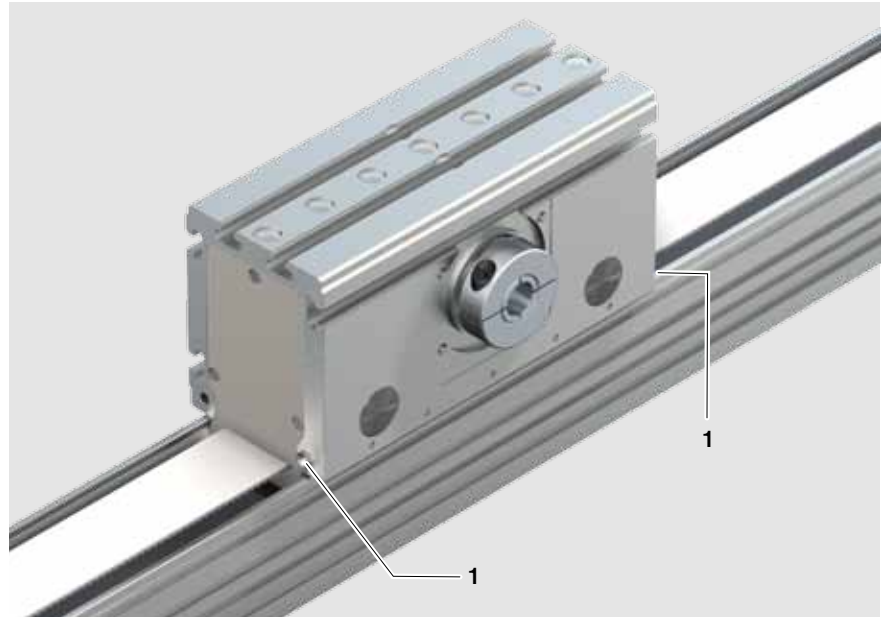

Recommended lubricants

For lubricant quantities and intervals, see "Instructions for Omega Modules".

⚠ Do not use greases containing solid particles (e.g. graphite or MoS₂)!

⚠ For lubrication in short-stroke applications (< 150 mm), please consult us.

OBB	Grease DIN 51825	Consistency class DIN 51818	Recommended grease	Part number (400 g cartridge)
55, 85, 120	KP2K-20	NLGI 2	Dynalub 510	R3416 037 00

Documentation

Standard report

Option 01

The standard report serves to confirm that the checks listed in the report have been carried out and that the measured values lie within the permissible tolerances.

Checks listed in the standard report:

- functional checks of mechanical components
- functional checks of electrical components
- design is in accordance with order confirmation

Further Information

Internet pages, Linear Motion and Assembly Technologies

Here you will find extensive information on products, eShop, EasyHandling and training and services offered.

Product information:

<http://www.boschrexroth.com/dcl>

1 Instructions and catalogs in PDF format and 3D CAD generator
 2 Printed catalogs and other publications
 3 Configurator

eShop:

<https://www.boschrexroth.com/eshop>

EasyHandling:
<http://www.easy-handling.com>

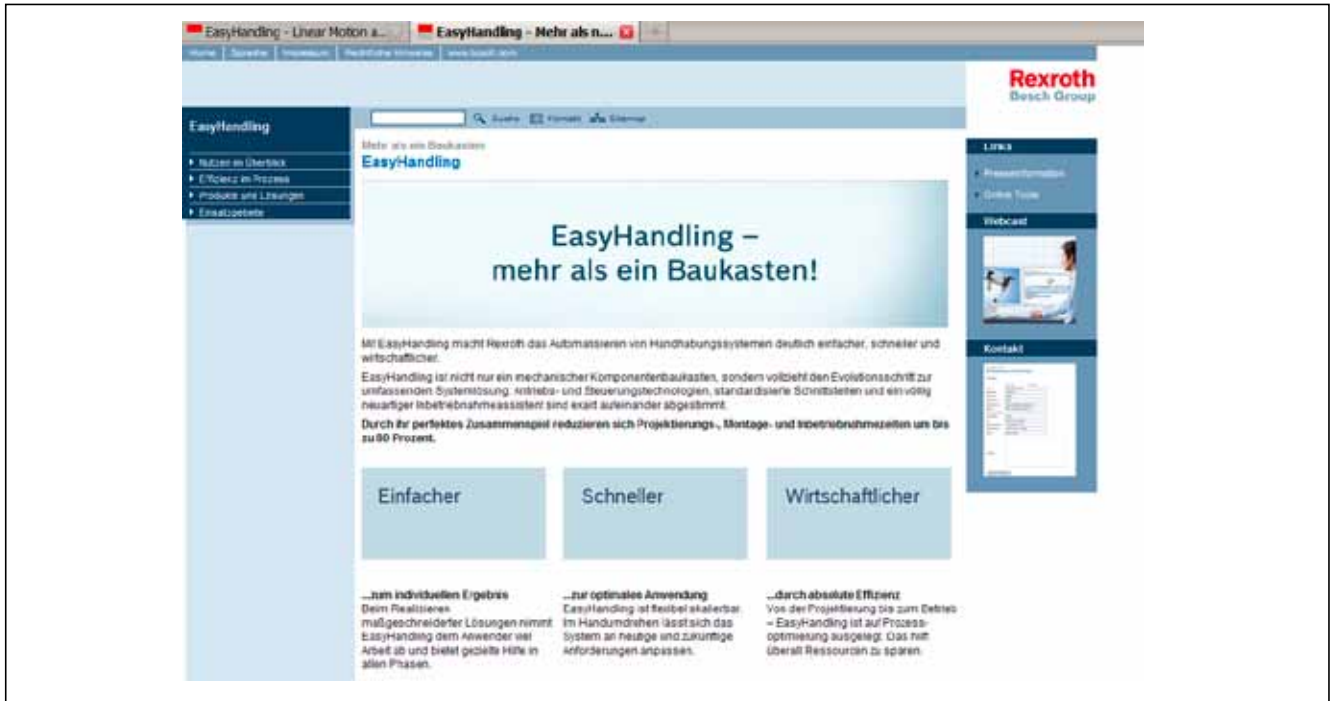

Training:
<http://www.boschrexroth.com/training>

Service:
<http://www.boschrexroth.com/service>



Further Information

Inquiry/Order

Bosch Rexroth AG
Linear Motion and Assembly Technologies
97419 Schweinfurt
Germany

Telephone +49 9721 937-0
Telefax +49 9721 937-350
(direct)

Rexroth – Omega Modules

Ordering example

Ordering Data		Description
Option	Option code	
Omega Module	OBB 85	Omega Module with toothed belt drive, length 910 mm
Part number, length	R1144 300 00, 910 mm	
Version	MG01	With angled gear reducer, mounted as shown in diagram MG01
Guideway	01	Ball Rail System
Drive unit	10	Toothed belt drive
Carriage	01	Carriage
Motor attachment	33	Angled gear reducer with i = 5, as per MG01, for motor MSK 050C
Motor	89	Motor MSK 050C with brake
1st switch	61	Proximity switch, PNP NC (frame travels)
2nd switch	65	Mechanical switch
3rd switch	65	Mechanical switch
Cable duct	20, 900 mm	Cable duct loose, length = 900 mm
Socket-plug	17	Socket-plug on switch side
Switching strip	41	Two switching strips for switch activation
Documentation	01	Measurement report: Standard report

To be completed by customer: Inquiry / Order

Omega Module _____

Part number: R _____, length _____ mm

Version =

Guideway =

Drive unit =

Carriage =

Motor attachment =

Motor =

1st switch = - + mm

2nd switch = - ± mm

3rd switch = - - mm

Cable duct = mm

Socket-plug =

Switching strip =

Documentation =

Individual parts (e.g. accessories, attachments):

Part number: R _____

R _____

R _____

R _____

Quantity Order of: _____ pcs, _____ per month, _____ per year, per order, or _____

Comments: _____

Sender Company: _____

Name: _____

Address: _____

Department: _____

Telephone: _____

Telefax: _____

Bosch Rexroth AG
Linear Motion and
Assembly Technologies
Ernst-Sachs-Straße 100
97424 Schweinfurt, Germany
Tel. +49 9721 937-0
Fax +49 9721 937-275
www.boschrexroth.com/dcl

Find your local contact person here:

www.boschrexroth.com/addresses-dcl

Subject to technical modifications

© Bosch Rexroth AG 2011
Printed in Germany
R310EN 2407 (2011-09)N
EN • DC-IA/MKT