

Planetary Screw Assemblies PLSA

R310EN 3308 (2011-09)

The Drive & Control Company









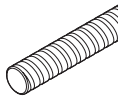
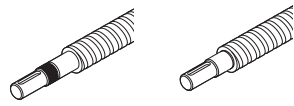

Planetary Screw Assemblies PLSA

Product Overview	3
Nuts, Screws, Screw Ends, Bearings	3
Planetary Screw Assembly – Definition	4
Application Examples	6
Inquiries and Orders	8
Nuts	10
Cylindrical Single Nut ZEM-E-S	10
Flanged Single Nut FEM-E-S	12
Flanged Single Nut, split FDM-E-S	14
Screws	16
Precision Screw PSR	16
Screw Ends	17
Form 002	17
Form 312	18
Form 412	20
Form 812 and 822	22
Form 832 and 842	24
Bearings	26
Bearing unit LAF	26
Bearing unit LAN	28
Bearing unit LAD	30
Bearing unit LAS	32
Bearing unit FEC-F	34
Slotted Nuts and Housing Nuts	36
Slotted Nuts NMA for Fixed Bearings	36
Technical Data	38
Acceptance Conditions and Tolerance Grades	41
Preload, Rigidity, Friction Torques	44
Mounting	46
End Bearings	48
Design Notes, Mounting Instructions	48
Lubrication	49
Design Calculations	50
End Bearings	56
Design Calculations	56
Design Calculation Service Form	58

Product Overview

Nuts, Screws, Screw Ends, Bearings

Nuts		Page
Cylindrical Single nut		10
ZEM-E-S		
with backlash		
Flanged Single Nut		12
FEM-E-S		
with backlash		
Flanged Single Nut split		14
FDM-E-S		
preloaded		
Screws		
Precision-rolled screw		16
PSR		
Tolerance grades		
T5, T7, T9		
Acceptance conditions		41
Screw end machining		
		17
Bearings		
LAF		26
LAN		28
LAD		30
LAS		32
FEC-F		34

Diameter d ₀ (mm)	Lead P (mm)	
	5	10
20	X	—
30	X	X
48	X	X

Planetary Screw Assembly – Definition

The Planetary Screw Assembly PLSA is an assembly comprising a screw with planets as the rolling elements. It serves to convert rotary motion into linear motion and vice versa.

The function principle of a planetary screw assembly is easy to describe, but the range of designs and the requirements for practical applications are many and varied.

Planetary Screw Assemblies are designed to transmit high forces and extend the Screw Drives product portfolio at the upper end.

Planetary Screw Assemblies are screw drives in which threaded rollers (the planets) are housed in a screw nut, their ends being lodged in discs with holes arranged around a pitch circle so that they rotate parallel to the axis of a special screw, causing the nut to move linearly along the screw.

Rexroth Planetary Screw Assemblies offer designers many opportunities to solve transport and positioning tasks in configurations with a driven screw. At Rexroth you will be sure to find exactly the kind of tailor-made products you need for special applications.

Structural Design:

Both the screw and the nut have an identical multi-start profile with a flank angle of 90°.

The planets have journals at both ends which are lodged in holes bored in the guide discs. The toothed ends of the planets engage with the internal gear rings of the nut. The planets have single-start threads and crowned flanks that roll without slipping along the nut threads.

At each end of the nut there is an internally geared ring which engages with the external gearing on the planets. Guide discs inside the gear rings support the planets' journals and ensure that they are correctly spaced. The discs also prevent coarse dirt from working its way into the nut.

Versions:

- Cylindrical Single Nut with backlash (ZEM-E-S)
- Flanged Single Nut with backlash (FEM-E-S)
- Flanged Single Nut, split, preloaded (FDM-E-S)

Precision Screws PSR

Bosch Rexroth has a long tradition of manufacturing precision screws. Offered in many sizes and in unmatched quality, these have for years been essential components in our Ball Screw Assemblies product range.

We have transferred this tried and trusted manufacturing technology to the screws of our Planetary Screw Assemblies. For users, this results in many advantages, including the following:

- Identical quality to Rexroth Ball Screw Assemblies
- Fast delivery
- Attractive prices thanks to cost-effective manufacturing



Advantages

- Smooth functioning due to the synchronized movement of the planets
- Very low noise
- High linear travel speeds
- Large number of contact points
- High load ratings
- High mechanical efficiency
- Long life
- Compact design
- High power density
- Effective wiper seals
- Low lubricant consumption
- Preloaded units available
- High positioning accuracy and repeatability

Product Overview

Application Examples

Rexroth Planetary Screw Assemblies are used with great success in many different application areas:

- Plastic injection molding machines
- Machine tools
- Measuring and material testing machines
- Robots
- Automotive industry
- Aerospace industry
- Automation and handling
- Food and packaging industries
- Printing and paper industry
- Medical technology
- Cutting operations
- Forming operations
- Metals industry

Electric press

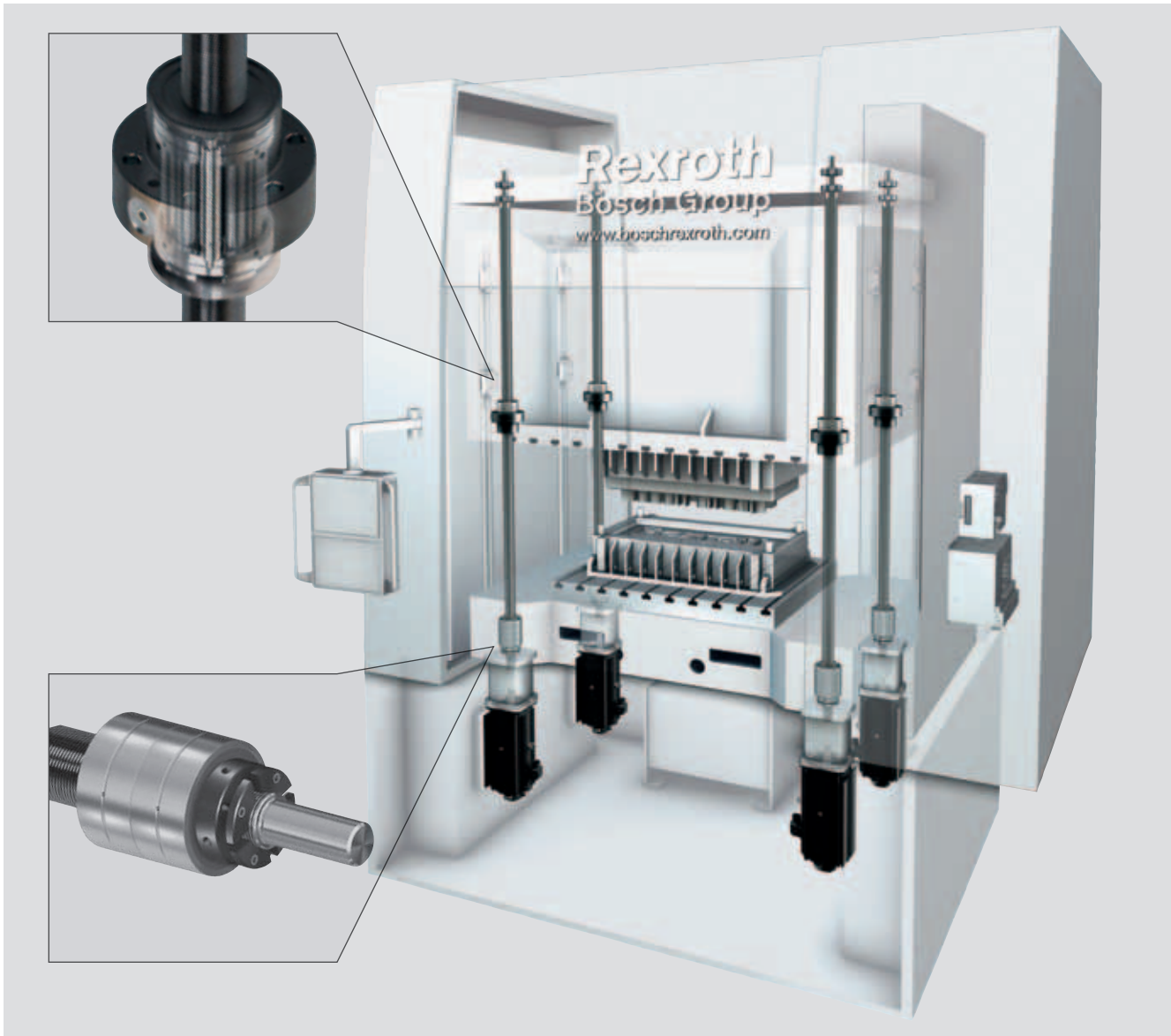

Friction welding machine





Product Overview

Inquiries and Orders

Nut type

The various series versions and forms are shown below.



Nuts	
Cylindrical Single nut	
ZEM-E-S	
with backlash	
Flanged Single Nut	
FEM-E-S	
with backlash	
Flanged Single Nut split	
FDM-E-S	
preloaded	

Mounting direction of nut types

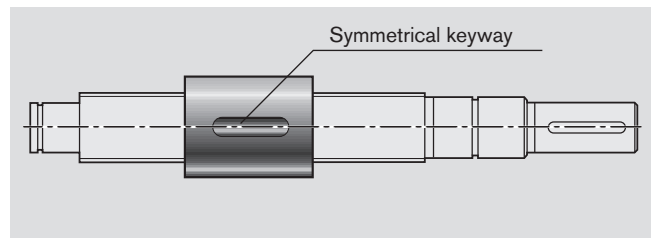
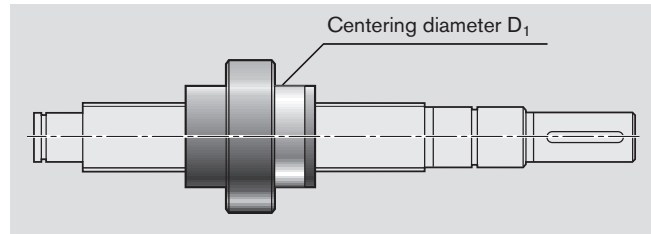
Definition: The centering diameter on a nut with flange points to the right end of the screw. For cylindrical nuts, the mounting direction can be chosen at will (symmetrical).

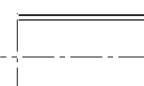
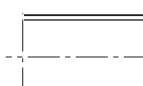
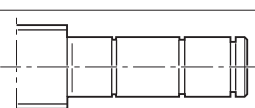
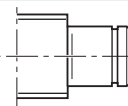
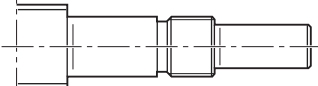
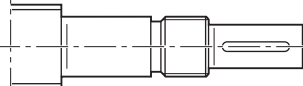
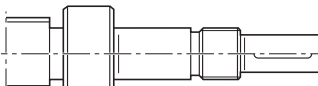

Screw ends, forms for a left or right screw end

Basic version	With keyway	Cut to size only „T“
002 		002 
312 		
412 		
812 	822 	End mechanically connected with/without keyway
		832 
		842 

Machining of end face

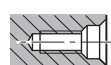
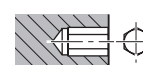
Z Centering hole DIN 332-D	S Hex socket
	

Complete PLSA (screw and nut)

Planetary Screw Assembly	FEM-E-S	20 x 5R	1	0	T7	R	812Z120	412Z120	1250	1	1
Nut type	ZEM-E-S Cylindrical Single nut FEM-E-S Flanged Single Nut FDM-E-S Flanged Single Nut, split										
Size	Nominal diameter (mm) ———— Lead (mm) ———— Direction of lead R ... right										
Seal	0 ... none 1 ... standard seal										
Preload	0 ... standard backlash 1 ... standard preload (for FDM-E-S only)										
Precision	T5, T7, T9										
Screw	R ... precision screw										
Left screw end	Form ———— Option ———— Z ... centering per DIN 332-D ———— S ... hex socket ———— K ... none ———— Version ————										
Right screw end	see left screw end										
Overall length L_{tot} (mm)											
Documentation	1 ... standard (acceptance test report) — is always supplied 2 ... torque test report 3 ... lead test report 6 ... lead and torque test report										
Lubrication	1 ... preserved and nut with basic greasing 2 ... preserved										

Nuts

Cylindrical Single Nut ZEM-E-S

- With standard seals
- With backlash max. 0.03 mm
- For precision screws PSR in tolerance grade T5, T7, T9

Note: Delivered only as a complete unit.



Ordering code

PLSA:

ZEM-E-S 20 x 5R 1 0 T7 R 822Z120 412Z120 1250 1 1

$d_0 \times P$	Nr.	C (kN)	C_0 (kN)	$v_{\max}^{1)}$ (m/min)
20 x 5R	R157C A10 03	55	80	37.5
30 x 5R	R157C 310 13	87	178	25.0
30 x 10R	R157C 330 03	101	174	50.0
48 x 5R	R157C 610 03	188	481	15.6
48 x 10R	R157C 630 03	220	475	31.2

1) See page 54 Characteristic speed and page 55 Critical speed

- C = dynamic load rating
 C_0 = static load rating
 $d_0 \times P$ = size
 d_0 = nominal diameter
 Nr. = part number
 P = lead (R = right-hand)
 S = lube port
 v_{\max} = maximum linear speed

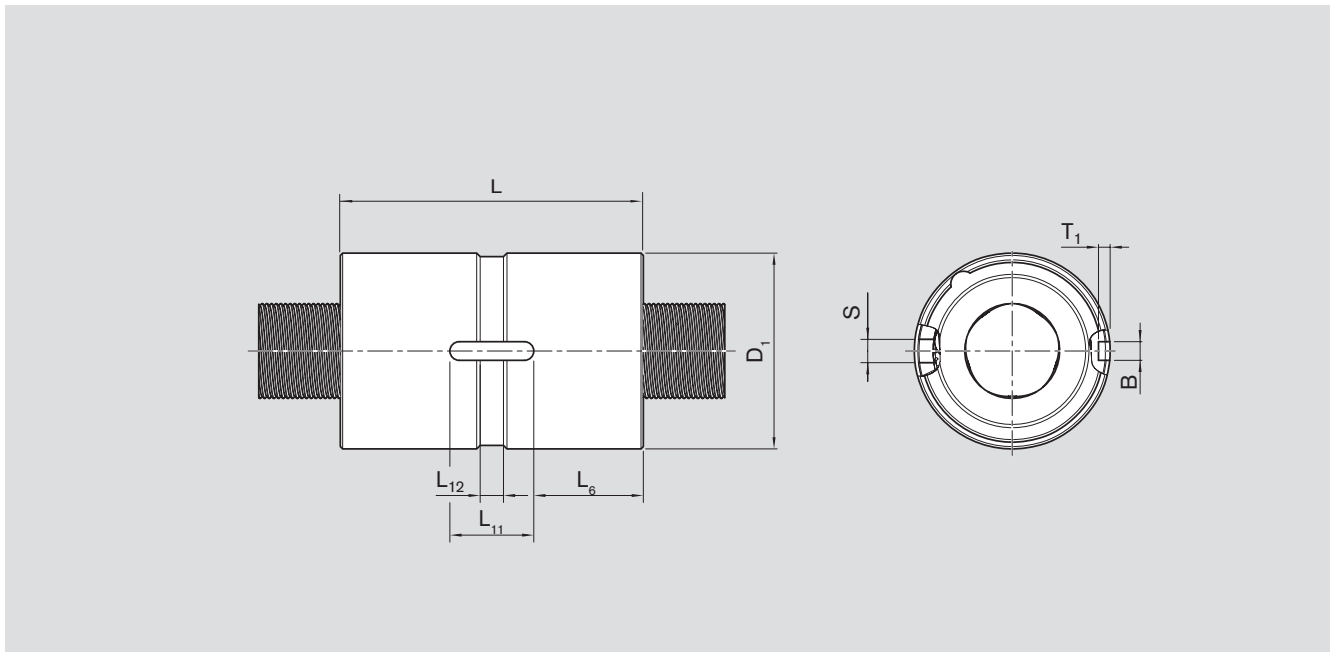

$d_0 \times P$	(mm)	$D_{1\ g6}$	L	B^{P9}	L_6	$L_{11}^{+0.2}$	L_{12}	$T_1^{+0.1}$
20 x 5R		42	65	4	23.5	18	5	2.5
30 x 5R		64	85	6	26.5	32	5	3.5
30 x 10R		64	85	6	26.5	32	5	3.5
48 x 5R		100	127	8	41.0	45	7	4.0
48 x 10R		100	127	8	41.0	45	7	4.0

Nuts

Flanged Single Nut FEM-E-S

- With standard seals
- With backlash max. 0.03 mm
- For precision screws PSR in tolerance grade T5, T7, T9

Note: Delivered only as a complete unit.



Ordering code

PLSA: **FEM-E-S** 20 x 5R 1 0 T5 R 812Z120 412Z120 1100 1 1

$d_0 \times P$	Nr.	C (kN)	C_0 (kN)	$v_{max}^{1)}$ (m/min)
20 x 5R	R157C A10 01	55	80	37.5
30 x 5R	R157C 310 11	87	178	25.0
30 x 10R	R157C 330 01	101	174	50.0
48 x 5R	R157C 610 01	188	481	15.6
48 x 10R	R157C 630 01	220	475	31.2

1) See page 54 Characteristic speed and page 55 Critical speed

- C = dynamic load rating
 C_0 = static load rating
 $d_0 \times P$ = size
 d_0 = nominal diameter
 Nr. = part number
 P = lead (R = right-hand)
 S = lube port
 v_{max} = maximum linear speed

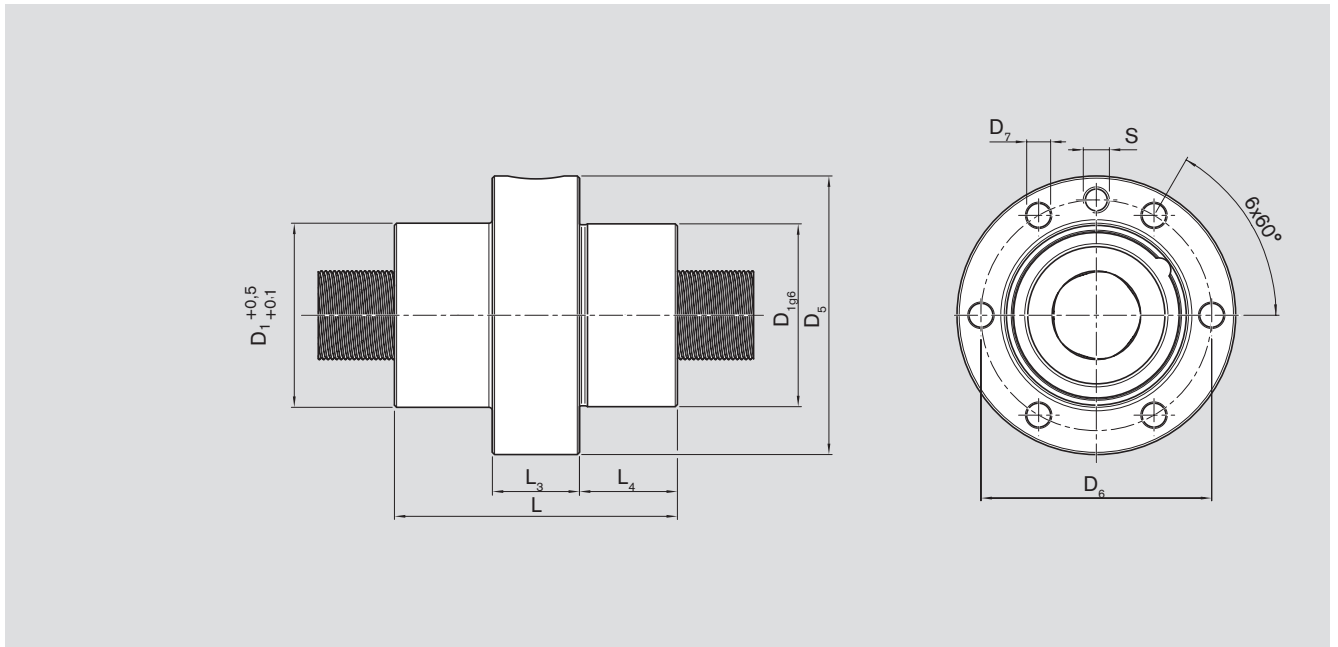

$d_0 \times P$	(mm)									
	D_1	D_5	L	D_6	D_7	L_3	L_4	S		
20 x 5R	42	64	65	53	5.5	20.0	22.5	M6		
30 x 5R	64	98	85	81	9.0	27.0	29.0	M6		
30 x 10R	64	98	85	81	9.0	27.0	29.0	M6		
48 x 5R	105	150	127	127	13.5	37.0	45.0	M8 x 1		
48 x 10R	105	150	127	127	13.5	37.0	45.0	M8 x 1		

Nuts

Flanged Single Nut, split FDM-E-S

- With standard seals
- With preload
- For precision screws PSR in tolerance grade T5, T7

Note: Delivered only as a complete unit.



Ordering code

PLSA: **FDM-E-S** 20 x 5R 1 0 T5 R 812Z120 412Z120 1100 1 1

$d_0 \times P$	Nr.	C (kN)	C_0 (kN)	$v_{max}^{1)}$ (m/min)
20 x 5R	R157C A10 02	32	40	37.5
30 x 5R	R157C 310 12	50	89	25.0
30 x 10R	R157C 330 02	58	87	50.0
48 x 5R	R157C 610 02	109	240	15.6
48 x 10R	R157C 630 02	127	237	31.2

1) See page 54 Characteristic speed and page 55 Critical speed

- C = dynamic load rating
 C_0 = static load rating
 $d_0 \times P$ = size
 d_0 = nominal diameter
 Nr. = part number
 P = lead (R = right-hand)
 S = lube port
 v_{max} = maximum linear speed

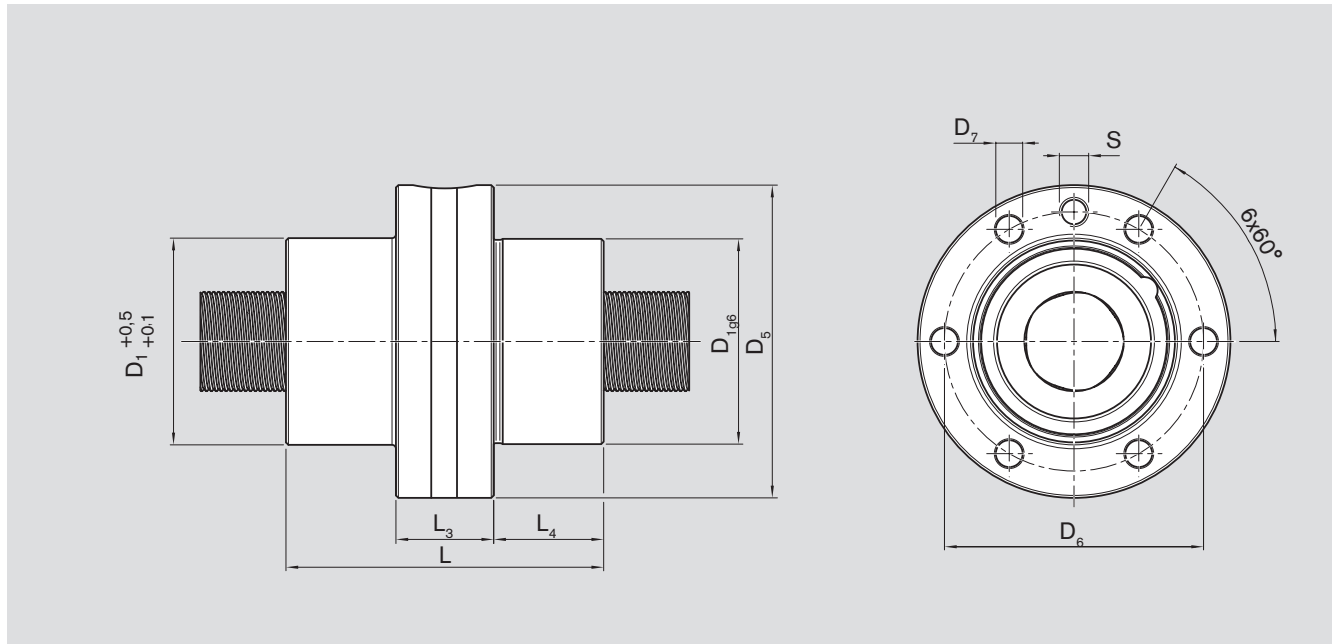

$d_0 \times P$	(mm)								
	D_1	D_5	L	D_6	D_7	L_3	L_4	S	
20 x 5R	42	64	65	53	5.5	20.0	22.5	M6	
30 x 5R	64	98	85	81	9.0	27.0	29.0	M6	
30 x 10R	64	98	85	81	9.0	27.0	29.0	M6	
48 x 5R	105	150	127	127	13.5	37.0	45.0	M8 x 1	
48 x 10R	105	150	127	127	13.5	37.0	45.0	M8 x 1	

Screws

Precision Screw PSR

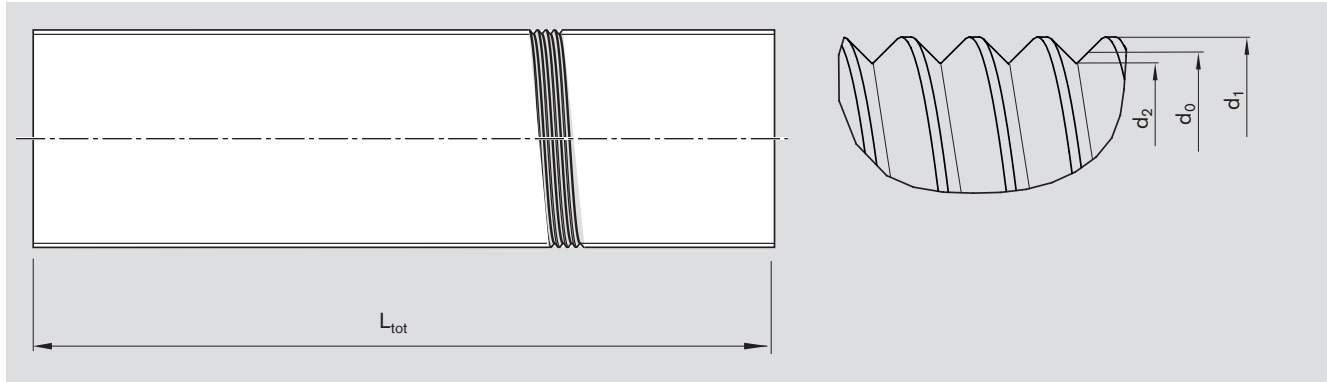

$d_0 \times P$	(mm)		Length		J_s (kgcm ² /m)	Weight (kg/m)
	d_1	d_2	Standard	On request		
20 x 5R	20.3	19.5	1 500	2 500	1.22	2.45
30 x 5R	30.3	29.5	3 000	5 000	6.21	5.54
30 x 10R	30.5	29.1			6.15	5.51
48 x 5R	48.3	47.5			40.88	14.21
48 x 10R	48.5	47.1			40.62	14.16

Precision screws PSR, with mechanically connected screw ends

- These screws consist of
- a precision screw part and
 - an unmachined spigot (as the screw journal).

The spigot is mechanically connected on one side and is available in different sizes.

We have a solution to prevent problems arising from big end bearing diameters (e.g. visible thread grooves or axial contact faces which are too small for the fixed bearing).

Please ask.

Separate delivery of a screw without end machining and without nut is not planned.

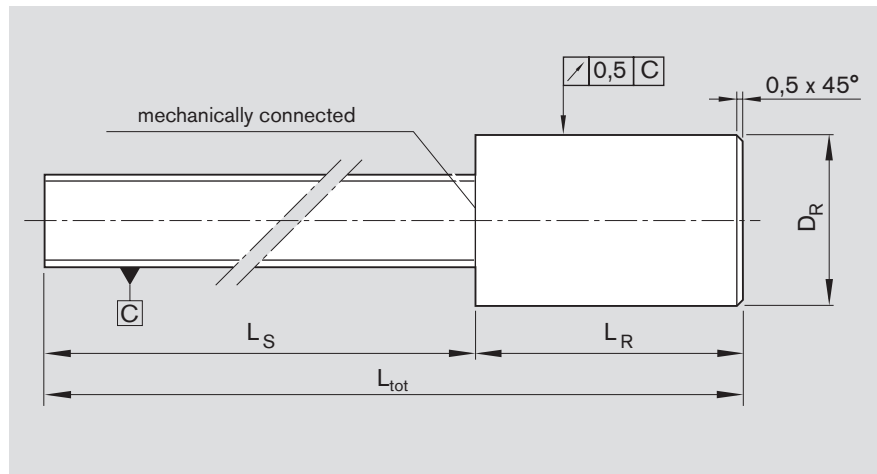

$d_0 \times P$ (mm)	Tolerance grade	(mm)			
		D_R -1	L_R +2	L_{tot}	L_S
20 x 5R	T5	36.4	200	1700	1500
30 x 5R		46.1	250	2050	1800
30 x 10R		46.1	250	2050	1800
48 x 5R		80.4	400	2300	1900
48 x 10R		80.4	400	2300	1900

- $d_0 \times P$ = size
- d_0 = nominal diameter
- J_s = moment of inertia
- P = lead (R = right-hand)

Screw Ends

Form 002

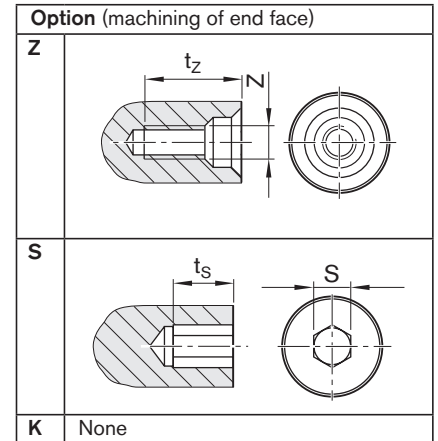
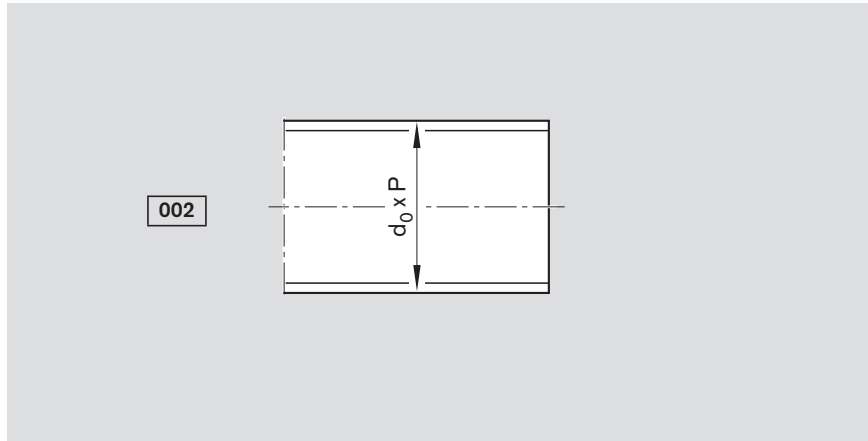

Ordering code PLSA:

FEM-E-S 20 x 5R 1 0 T7 R 002K200 822K120 1250 1 0

Form	Version	(mm)				
		$d_0 \times P$	Z	t_z	S	t_s
002	200	20 x 5	M6	16	8	8
	300	30 x 5/10	M10	22	12	12
	480	48 x 5/10	M16	36	17	17

- $d_0 \times P$ = size
- d_0 = nominal diameter
- P = lead (R = right-hand)
- S = hex socket
- Z = centering hole DIN 332-D

Screw Ends

Form 312

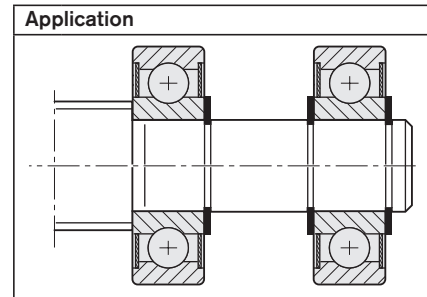
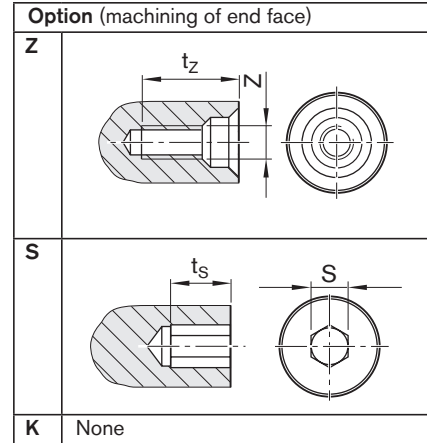
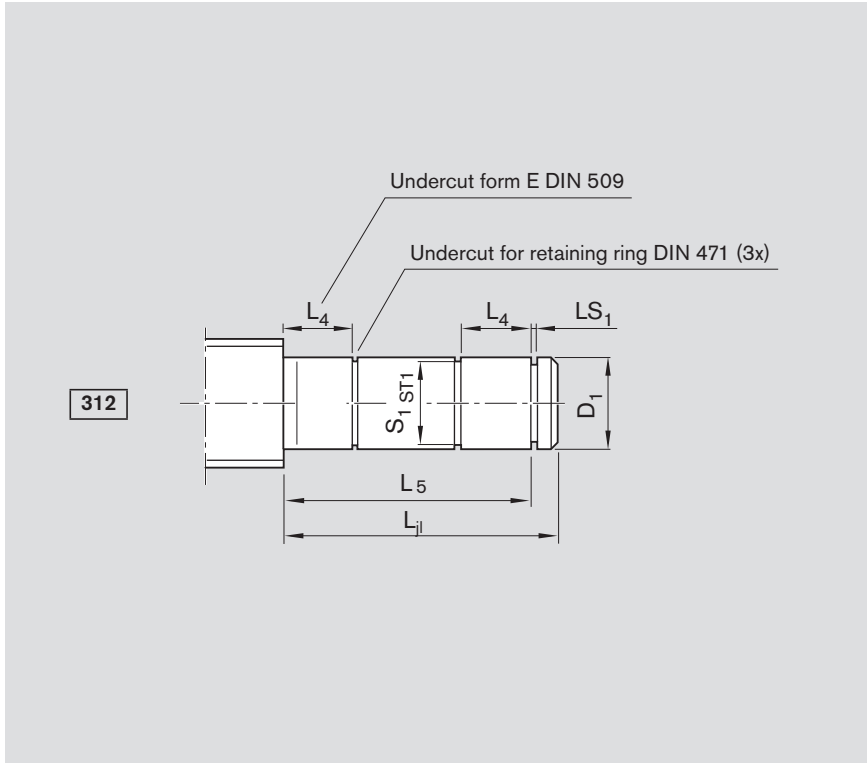

Ordering code PLSA:

FEM-E-S 20 x 5R 1 0 T7 R 312Z120 822Z120 1250 1 0

Form	Version ¹⁾	(mm)											
		$d_0 \times P$	D_1 j6	L_{jl}	L_4	L_5	S_1	ST1	LS_1 H13	Z	t_z	S	t_s
312	120	20 x 5R	12	43	10	40	11.5	h11	1.10	M4	10.0	4	4
	150	20 x 5R	15	47	11	44	14.3	h11	1.10	M5	12.5	4	4
	200	30 x 5R/10R	20	60	14	56	19.0	h11	1.30	M6	16.0	5	5
	250	30 x 5R/10R	25	64	15	60	23.9	h12	1.30	M10	22.0	8	8
	350	48 x 5R/10R	35	73	17	68	33.0	h12	1.60	M12	28.0	12	12

1) The allocation of screw ends to the bearing units is defined by the version.

Note: Form 312 with two floating bearings increases the critical speed, see page 54.

- $d_0 \times P$ = size
- d_0 = nominal diameter
- Nr. = part number
- P = lead (R = right-hand)
- S = hex socket
- Z = centering hole DIN 332-D

End bearings for screw ends form 312

The bearing unit LAD consists of:

- 1 bearing (2x required)
- 2 retaining rings



Form	Version	d ₀ x P	LAD Nr.
312	120	20 x 5R	R1590 612 00
	150	20 x 5R	R1590 615 00
	200	30 x 5R/10R	R1590 620 00
	250	30 x 5R/10R	R1590 625 00
	350	48 x 5R/10R	R1590 635 00

Screw Ends

Form 412

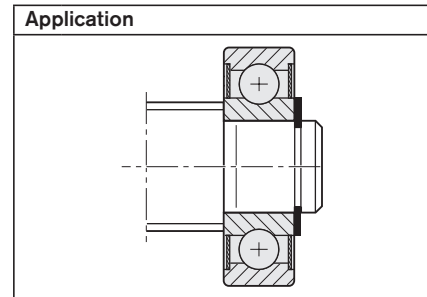
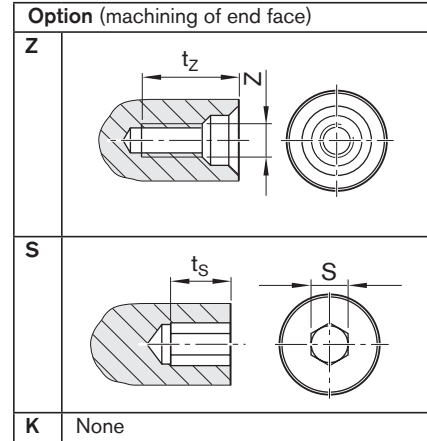
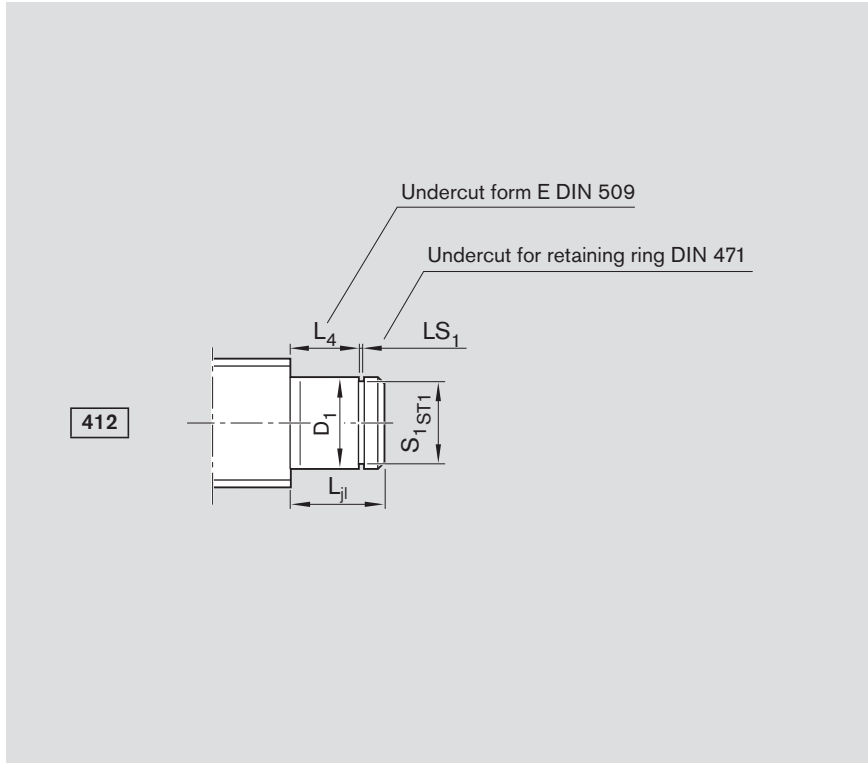

Ordering code PLSA:

FEM-E-S 20 x 5R 1 0 T7 R 412Z120 822Z120 1250 1 0

Form	Version ¹⁾	(mm)											
		d ₀ x P	D ₁ j6	L _{II}	L ₄	S ₁	ST1	LS ₁ H13	Z	t _z	S	t _s	
412	120	20 x 5R	12	13	10	11.5	h11	1.10	M4	10	4	4	
	150	20 x 5R	15	14	11	14.3	h11	1.10	M5	12.5	4	4	
	200	30 x 5R/10R	20	18	14	19.0	h11	1.30	M6	16	5	5	
	250	30 x 5R/10R	25	19	15	23.9	h12	1.30	M10	22	8	8	
	350	48 x 5R/10R	35	22	17	33.0	h12	1.60	M12	28	12	12	

1) The allocation of screw ends to the bearing units is defined by the version.

- d₀ x P = size
- d₀ = nominal diameter
- Nr. = part number
- P = lead (R = right-hand)
- S = hex socket
- Z = centering hole DIN 332-D

End bearings for screw ends form 412

The bearing unit LAD consists of:

- 1 bearing
- 2 retaining rings



Form	Version	d ₀ x P	LAD Nr.
412	120	20 x 5R	R1590 612 00
	150	20 x 5R	R1590 615 00
	200	30 x 5R/10R	R1590 620 00
	250	30 x 5R/10R	R1590 625 00
	350	48 x 5R/10R	R1590 635 00

Screw Ends

Form 812 and 822

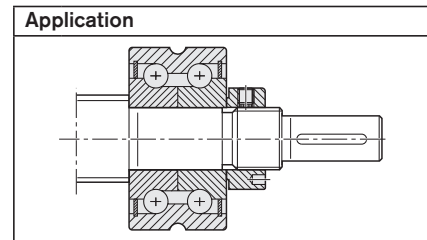
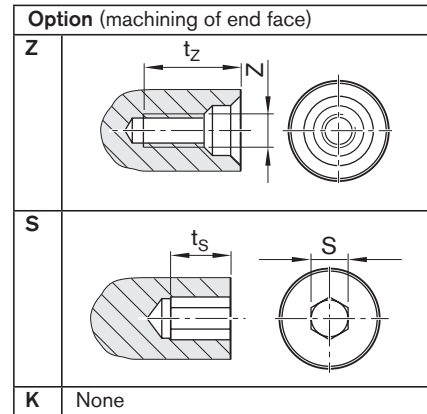
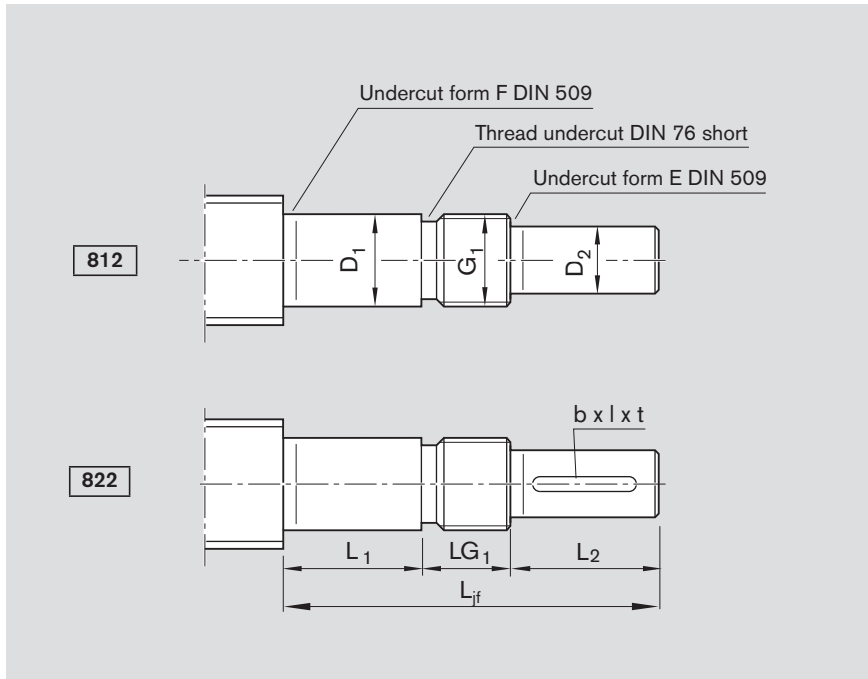

Ordering code PLSA:

FEM-E-S 20 x 5R 1 0 T7 R 822Z120 412Z120 1250 1 0

Form	Version ¹⁾	d ₀ x P	(mm)										Keyway per DIN 6885		Z	S		Mp (Nm)
			L _{jf}	D ₁ h6	L ₁	D ₂ h7	L ₂	G ₁	LG ₁	b P9	l	t	t _Z	t _S				
812	150	20 x 5R	70	15	23	12	25	M15x1	22	-	-	-	M4	10	4	4	12.1	
	153	20 x 5R	97	15	50	12	25	M15x1	22	-	-	-	M4	10	4	4	12.1	
	205	30 x 5R	116	20	54	18	40	M20x1	22	-	-	-	M6	16	5	5	22.8	
		30 x 10R	116	20	54	18	40	M20x1	22	-	-	-	M6	16	5	5	38.8	
	206	30 x 5R	120	20	58	18	40	M20x1	22	-	-	-	M6	16	5	5	22.8	
		30 x 10R	120	20	58	18	40	M20x1	22	-	-	-	M6	16	5	5	38.8	
	351	48 x 5R	140	35	66	30	50	M35x1,5	24	-	-	-	M10	22	10	10	59.9	
		48 x 10R	140	35	66	30	50	M35x1,5	24	-	-	-	M10	22	10	10	117.1	
	352	48 x 5R	156	35	82	30	50	M35x1,5	24	-	-	-	M10	22	10	10	59.9	
		48 x 10R	156	35	82	30	50	M35x1,5	24	-	-	-	M10	22	10	10	117.1	
822	150	20 x 5R	70	15	23	12	25	M15x1	22	4	20	2.5	M4	10	4	4	12.1	
	153	20 x 5R	97	15	50	12	25	M15x1	22	4	20	2.5	M4	10	4	4	12.1	
	205	30 x 5R	116	20	54	18	40	M20x1	22	6	28	3.5	M6	16	5	5	22.8	
		30 x 10R	116	20	54	18	40	M20x1	22	6	28	3.5	M6	16	5	5	38.8	
	206	30 x 5R	120	20	58	18	40	M20x1	22	6	28	3.5	M6	16	5	5	22.8	
		30 x 10R	120	20	58	18	40	M20x1	22	6	28	3.5	M6	16	5	5	38.8	
	351	48 x 5R	140	35	66	30	50	M35x1,5	24	8	36	4.0	M10	22	10	10	59.9	
		48 x 10R	140	35	66	30	50	M35x1,5	24	8	36	4.0	M10	22	10	10	117.1	
	352	48 x 5R	156	35	82	30	50	M35x1,5	24	8	36	4.0	M10	22	10	10	59.9	
		48 x 10R	156	35	82	30	50	M35x1,5	24	8	36	4.0	M10	22	10	10	117.1	

1) The allocation of screw ends to the bearing units is defined by the version.

End bearings for screw ends form 812 and 822

The bearing unit LAF, LAN, LAS consists of:

- 1 bearing
- 1 slotted nut

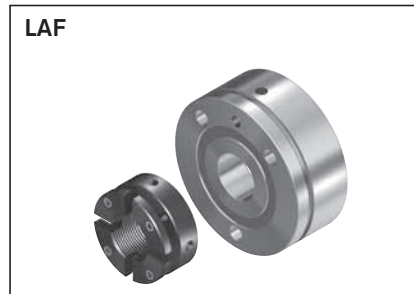

Form	Version	d ₀ x P	Nr.		
			LAF	LAN	LAS
812	150	20 x 5R	R159A 015 01	R159A 115 01	-
	153	20 x 5R	-	-	R159A 415 01
	205	30 x 5R	R159A 320 01	R159A 220 01	-
		30 x 10R	R159A 320 01	R159A 220 01	-
	206	30 x 5R	-	-	R159A 420 02
		30 x 10R	-	-	R159A 420 02
	351	48 x 5R	R159A 335 01	R159A 235 01	-
		48 x 10R	R159A 335 01	R159A 235 01	-
	352	48 x 5R	-	-	R159A 435 01
		48 x 10R	-	-	R159A 435 01
822	150	20 x 5R	R159A 015 01	R159A 115 01	-
	153	20 x 5R	-	-	R159A 415 01
	205	30 x 5R	R159A 320 01	R159A 220 01	-
		30 x 10R	R159A 320 01	R159A 220 01	-
	206	30 x 5R	-	-	R159A 420 02
		30 x 10R	-	-	R159A 420 02
	351	48 x 5R	R159A 335 01	R159A 235 01	-
		48 x 10R	R159A 335 01	R159A 235 01	-
	352	48 x 5R	-	-	R159A 435 01
		48 x 10R	-	-	R159A 435 01

d₀ x P = size

d₀ = nominal diameter

M_p = maximum permissible drive torque (precondition: no radial load at drive journal)

Nr. = part number

P = lead (R = right-hand)

S = hex socket

Z = centering hole DIN 332-D

Screw Ends

Form 832 and 842

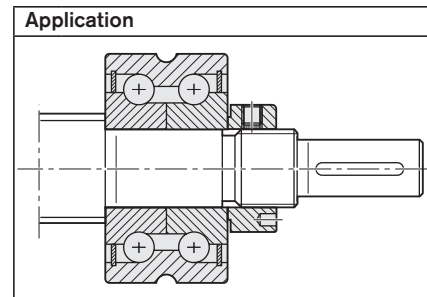
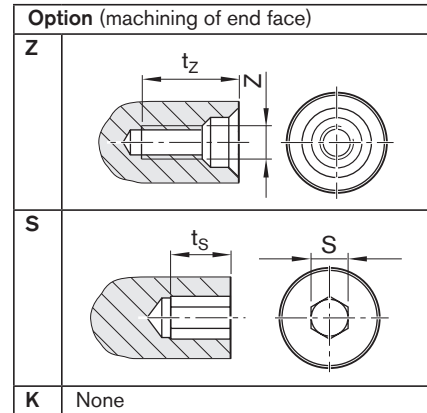
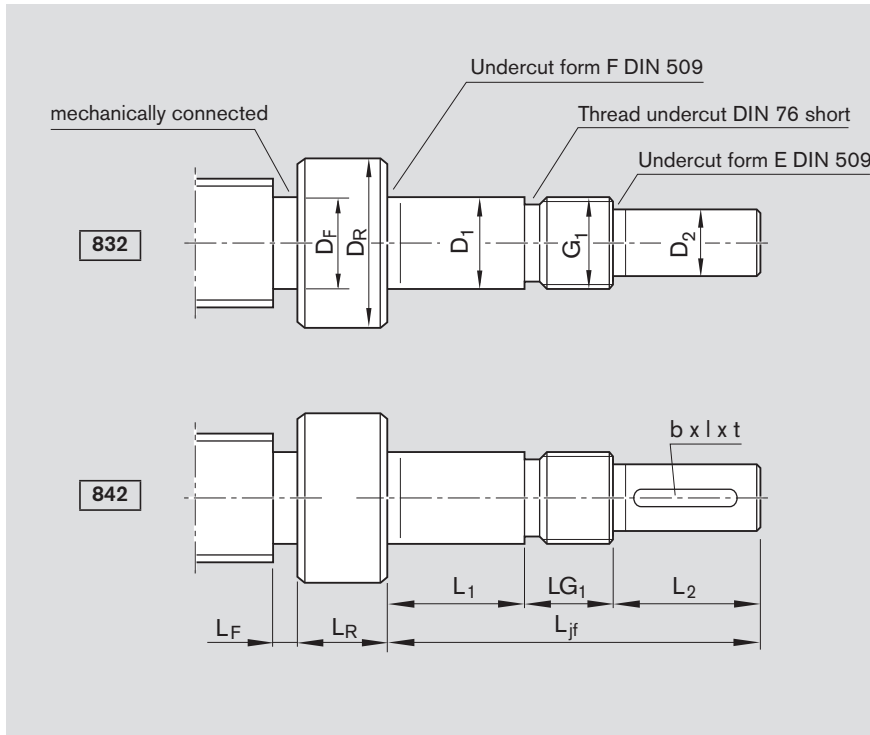

Ordering code PLSA:

FEM-E-S 20 x 5R 1 0 T7 R 832Z200 312Z120 1250 1 0

Form	Version ¹⁾	(mm)										Keyway per DIN 6885			Z	S	Mp (Nm)
		d ₀ x P	L _{jf}	D ₁ h6	L ₁	D ₂ h7	L ₂	G ₁	LG ₁	b P9	l	t	t _z	S			
832	201	20 x 5R	116	20	54	18	40	M20x1	22	-	-	-	M6	16	5	5	23.0
	251	20 x 5R	157	25	87	20	45	M25x1.5	25	-	-	-	M6	16	5	5	28.3
	301	30 x 5R	148	30	74	25	50	M30x1.5	24	-	-	-	M10	22	8	8	46.2
	302	30 x 10R	148	30	74	25	50	M30x1.5	24	-	-	-	M10	22	8	8	85.8
	350	30 x 5R	189	35	108	30	55	M35x1.5	26	-	-	-	M10	22	8	8	57.1
	351	30 x 10R	189	35	108	30	55	M35x1.5	26	-	-	-	M10	22	8	8	106.8
	503	48 x 5R	205	50	106	40	70	M50x1.5	29	-	-	-	M16	36	12	12	112.2
	504	48 x 10R	205	50	106	40	70	M50x1.5	29	-	-	-	M16	36	12	12	221.1
	650	48 x 5R	310	65	178	60	100	M65x2	32	-	-	-	M20	42	17	17	143.3
	651	48 x 10R	310	65	178	60	100	M65x2	32	-	-	-	M20	42	17	17	276.8
842	201	20 x 5R	116	20	54	18	40	M20x1	22	6	36	3.5	M6	16	5	5	23.0
	251	20 x 5R	157	25	87	20	45	M25x1.5	25	6	40	3.5	M6	16	5	5	28.3
	301	30 x 5R	148	30	74	25	50	M30x1.5	24	8	40	4.0	M10	22	8	8	46.2
	302	30 x 10R	148	30	74	25	50	M30x1.5	24	8	40	4.0	M10	22	8	8	85.8
	350	30 x 5R	189	35	108	30	55	M35x1.5	26	8	45	4.0	M10	22	8	8	57.1
	351	30 x 10R	189	35	108	30	55	M35x1.5	26	8	45	4.0	M10	22	8	8	106.8
	503	48 x 5R	205	50	106	40	70	M50x1.5	29	12	50	5.0	M16	36	12	12	112.2
	504	48 x 10R	205	50	106	40	70	M50x1.5	29	12	50	5.0	M16	36	12	12	221.1
	650	48 x 5R	310	65	178	60	100	M65x2	32	18	90	7.0	M20	42	17	17	143.3
	651	48 x 10R	310	65	178	60	100	M65x2	32	18	90	7.0	M20	42	17	17	276.8

1) The allocation of screw ends to the bearing units is defined by the version.

End bearings for screw ends form 832 and 842

The bearing unit LAS, FEC-F consists of:

- 1 bearing
- 1 slotted nut



Form	Version	(mm)				Nr.		
		$d_0 \times P$	D_R	L_R	D_F	$L_{F \max}$	LAS	FEC-F
832	201	20 x 5R	27	7	19	14	R159A 420 01	-
	251	20 x 5R	34	7	19	26	-	R159B 425 01
	301	30 x 5R	40	10	29	17	R159A 430 01	-
	302	30 x 10R	40	10	28.5	17	R159A 430 01	-
	350	30 x 5R	45	10	29	28	-	R159B 435 01
	351	30 x 10R	45	10	28.5	28	-	R159B 435 01
	503	48 x 5R	62	12	47	22	R159A 450 01	-
	504	48 x 10R	62	12	46.5	22	R159A 450 01	-
	650	48 x 5R	78	18	47	46	-	R159B 465 01
	651	48 x 10R	78	18	46.5	46	-	R159B 465 01
842	201	20 x 5R	27	7	19	14	R159A 420 01	-
	251	20 x 5R	34	7	19	26	-	R159B 425 01
	301	30 x 5R	40	10	29	17	R159A 430 01	-
	302	30 x 10R	40	10	28.5	17	R159A 430 01	-
	350	30 x 5R	45	10	29	28	-	R159B 435 01
	351	30 x 10R	45	10	28.5	28	-	R159B 435 01
	503	48 x 5R	62	12	47	22	R159A 450 01	-
	504	48 x 10R	62	12	46.5	22	R159A 450 01	-
	650	48 x 5R	78	18	47	46	-	R159B 465 01
	651	48 x 10R	78	18	46.5	46	-	R159B 465 01

$d_0 \times P$ = size

d_0 = nominal diameter

M_p = maximum permissible drive torque (precondition: no radial load at drive journal)

Nr. = part number

P = lead (R = right-hand)

S = hex socket

Z = centering hole DIN 332-D

Bearings

Bearing unit LAF

Fixed bearing with angular-contact thrust ball bearing LGF

Double-thrust, screw-down,
Series LGF-B-...

Double-thrust, screw-down,
Series LGF-C-...

The bearing unit consists of:

- angular-contact thrust ball bearing LGF (not available as a separate part)
- slotted nut NMA...



d ₀ x P	LAF	LGF	NMA		Weight complete (kg)
	Nr.	Designation	Designation	Nr.	
20 x 5R	R159A 015 01	LGF-B-1560	NMA 15x1	R3446 020 04	0.49
30 x 5R/10R	R159A 320 01	LGF-C-2068	NMA 20x1	R3446 015 04	1.35
48 x 5R/10R	R159A 335 01	LGF-C-3590	NMA 35x1.5	R3446 012 04	2.49

d ₀ x P	C (N)	C ₀ (N)	M _{RL} (Nm)	R _{fb} (N/μm)	R _{kl} (Nm/mrad)	n _G (min ⁻¹)
20 x 5R	17900	28000	0,20	400	65	3500
30 x 5R/10R	42000	94000	0,45	1150	320	3000
48 x 5R/10R	66000	177000	0,90	1600	900	2000

Suitable for screw ends: Form

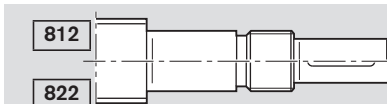

C = dynamic load rating
 C₀ = static load rating
 d₀ x P = size
 d₀ = nominal diameter
 M_{RL} = Bearing friction torque with seal
 n_G = Limit speed (grease)
 Nr. = part number

P = lead (R = right-hand)
 R_{fb} = Rigidity (axial)
 R_{kl} = Rigidity against tilting

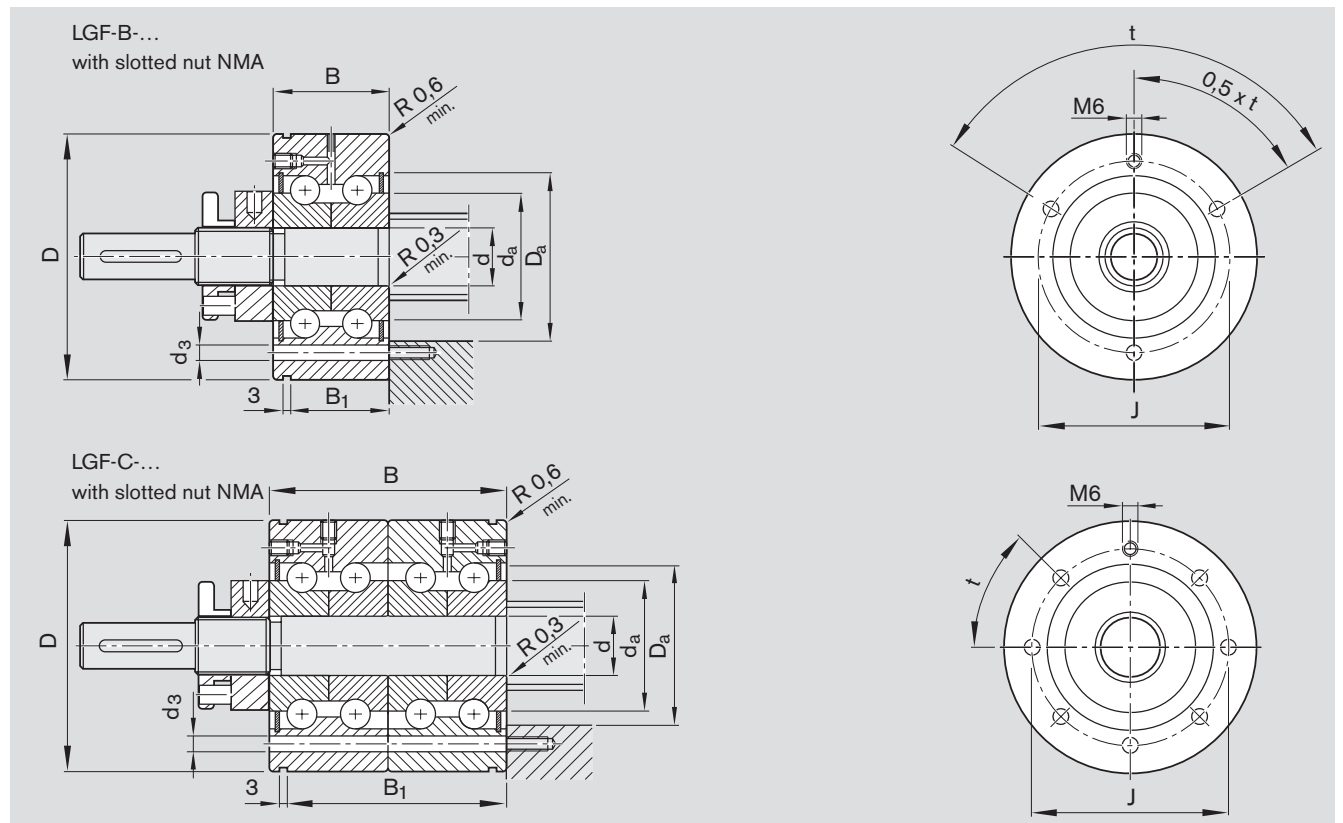

$d_0 \times P$	(mm)										Mounting holes		
	d	D	B	B ₁	J	min.	D _a max.	min.	d _a max.	Number	d ₃ (mm)	t (°)	
20 x 5R	15 _{-0.010}	60 _{-0.013}	25 _{-0.25}	17	46	32	35	20	31	3	6.8	120	
30 x 5R/10R	20 _{-0.005}	68 _{-0.010}	56 _{-0.50}	47	53	40	43	25	39	7	6.8	45	
48 x 5R/10R	35 _{-0.005}	90 _{-0.010}	68 _{-0.50}	59	75	59	62	45	58	7	8.8	45	

Bearings

Bearing unit LAN

Fixed bearing with angular-contact thrust ball bearing LGN

Double-thrust,

Series LGN-B-...

Double-thrust, in pairs,

Series LGN-C-...

The bearing unit consists of:

- angular-contact thrust ball bearing LGN (not available as a separate part)
- slotted nut NMA...



$d_0 \times P$	LAN Nr.	LGN Designation	NMA		Weight complete (kg)
			Designation	Nr.	
20 x 5R	R159A 115 01	LGN-B-1545	NMA 15x1	R3446 020 04	0.27
30 x 5R/10R	R159A 220 01	LGN-C-2052	NMA 20x1	R3446 015 04	0.75
48 x 5R/10R	R159A 235 01	LGN-C-3572	NMA 35x1.5	R3446 012 04	1.25

$d_0 \times P$	C (N)	C_0 (N)	M_{RL} (Nm)	R_{fb} (N/ μ m)	R_{kl} (Nm/mrad)	n_G (min^{-1})
20 x 5R	17900	28000	0.20	400	65	3500
30 x 5R/10R	42000	94000	0.45	1150	320	3000
48 x 5R/10R	66000	177000	0.90	1600	900	2000

Suitable for screw ends: Form

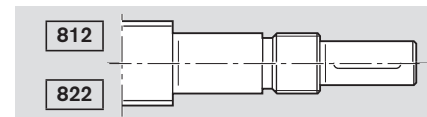

C = dynamic load rating
 C_0 = static load rating
 $d_0 \times P$ = size
 d_0 = nominal diameter
 M_{RL} = Bearing friction torque with seal
 n_G = Limit speed (grease)
 Nr. = part number

P = lead (R = right-hand)
 R_{fb} = Rigidity (axial)
 R_{kl} = Rigidity against tilting
 P = lead (R = right-hand)

LGN-B-...
with slotted nut NMA

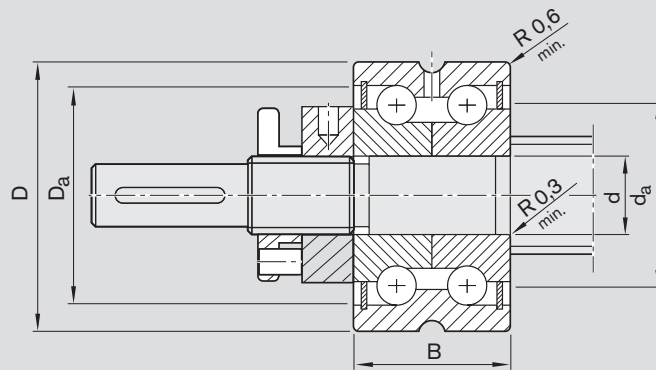

LGN-C-...
with slotted nut NMA

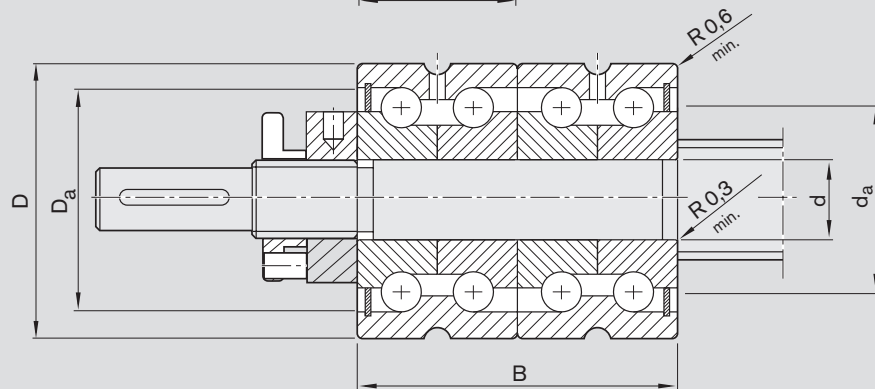

$d_0 \times P$	(mm)							
	d	D	B	d	D_a	d	d_a	
				min.	max.	min.	max.	
20 x 5R	15 _{-0.010}	45 _{-0.01}	25 _{-0.25}	32	35	20	31	
30 x 5R/10R	20 _{-0.005}	52 _{-0.01}	56 _{-0.50}	40	43	25	39	
48 x 5R/10R	35 _{-0.005}	72 _{-0.01}	68 _{-0.50}	59	62	45	58	

Bearings

Bearing unit LAD

Floating bearing with deep-groove ball bearing

The bearing unit consists of:

- deep-groove ball bearing per DIN 625... .2RS
- retaining ring DIN 471 (2 pcs)



$d_0 \times P$	LAD Nr.	Single parts Deep-groove ball bearing DIN 625		Retaining ring DIN 471		C (N)	C ₀ (N)	Weight complete (kg)
		Designation	Nr.	Designation	Nr.			
20 x 5R	R1590 612 00	6201.2RS	R3414 042 00	12x1	R3410 712 00	6950	2650	0.035
	R1590 615 00	6202.2RS	R3414 074 00	15x1	R3410 748 00	7800	3250	0.043
30 x 5R/10R	R1590 620 00	6204.2RS	R3414 038 00	20x1.2	R3410 735 00	12700	5700	0.106
	R1590 625 00	6205.2RS	R3414 063 00	25x1.2	R3410 750 00	14300	6950	0.125
48 x 5R/10R	R1590 635 00	6207.2RS	R3414 075 00	35x1.5	R3410 725 00	25500	13200	0.288

Suitable for screw ends: Form

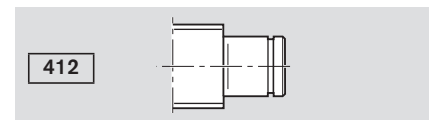
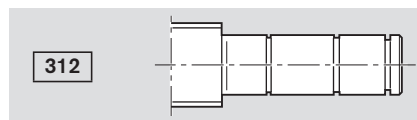

- C = dynamic load rating
 C₀ = static load rating
 $d_0 \times P$ = size
 d_0 = nominal diameter
 Nr. = part number
 P = lead (R = right-hand)

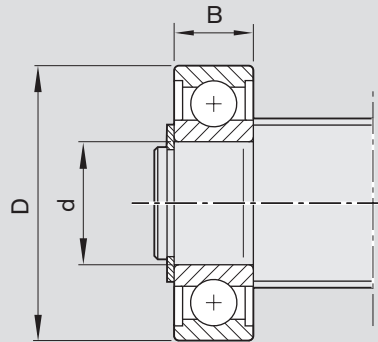

$d_0 \times P$	(mm)		
	d	D	B
20 x 5R	12	32	10
	15	35	11
30 x 5R/10R	20	47	14
	25	52	15
48 x 5R/10R	35	72	17

Bearings

Bearing unit LAS

Fixed bearing with angular-contact thrust ball bearing LGS

Double-thrust

Series LAS-E

The bearing unit consists of:

- angular-contact thrust ball bearing LGS per DIN 628 (not available as a separate part)
- slotted nut NMA...



$d_0 \times P$	LAS Nr	LGS Designation	NMA		C (kN)	C_0 (kN)
			Designation	Nr.		
20 x 5R	R159A 415 01	LGS-E-1542	NMA 15x1	R3446 020 04	37.1	51.5
	R159A 420 01	LGS-E-2047	NMA 20x1	R3446 015 04	39.9	63.8
30 x 5R/10R	R159A 420 02	LGS-E-2052	NMA 20x1	R3446 015 04	54.2	80.0
	R159A 430 01	LGS-E-3072	NMA 30x1.5	R3446 016 04	98.3	163.1
48 x 5R/10R	R159A 435 01	LGS-E-3580	NMA 35x1.5	R3446 012 04	111.2	188.5
	R159A 450 01	LGS-E-50110	NMA 50x1.5	R3446 019 04	211.2	392.3

Suitable for screw ends: Form

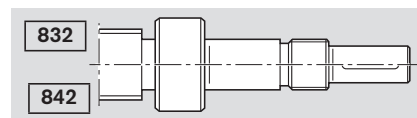
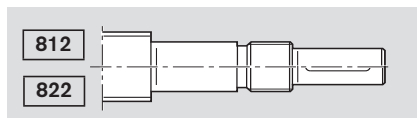

- C = dynamic load rating
 C_0 = static load rating
 $d_0 \times P$ = size
 d_0 = nominal diameter
 Nr. = part number
 P = lead (R = right-hand)

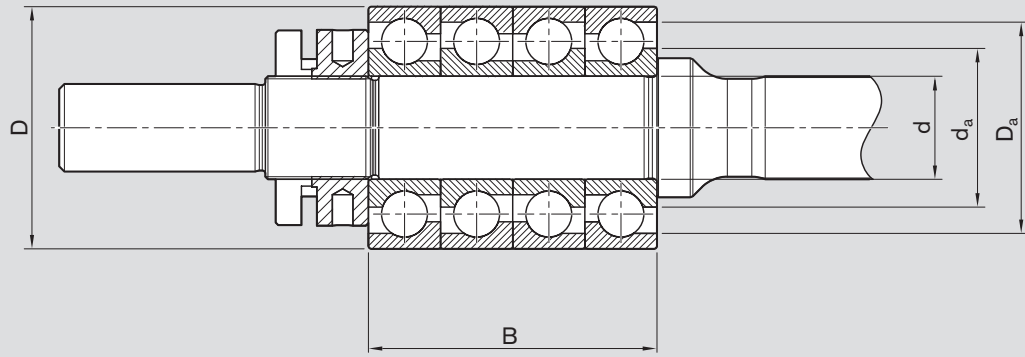

$d_0 \times P$	(mm)								Weight complete (kg)
	d	D	B	D_a		d_a			
				min.	max.	min.	max.		
20 x 5R	15 _{-0.008}	42 _{-0.011}	52	32.6	37.8	20.6	31.6	0.39	
	20 _{-0.010}	47 _{-0.011}	56	39.0	42.8	25.6	38.0	0.57	
30 x 5R/10R	20 _{-0.010}	52 _{-0.013}	60	40.4	47.8	27.0	39.4	0.73	
	30 _{-0.010}	72 _{-0.013}	76	56.5	67.8	37.0	55.5	1.68	
48 x 5R/10R	35 _{-0.012}	80 _{-0.013}	84	63.3	74.4	44.0	62.3	2.19	
	50 _{-0.012}	110 _{-0.015}	108	88.8	104.0	61.0	87.8	4.95	

Bearings

Bearing unit FEC-F

Fixed bearing with angular-contact thrust ball bearing LGS

The bearing unit consists of:

- Precision steel flanged housing
- angular-contact thrust ball bearing LGS
- slotted nut NMB

The slotted nut is delivered unmounted



d ₀ x P	FEC-F Nr.	LGS Designation	NMB Designation	M _A (Nm)	Weight complete	C	C ₀
					(kg)	(N)	(N)
20 x 5R	R159B 425 01	LGS-E-2562	NMB 25x1.5	25	3.5	74.2	119.2
30 x 5R/10R	R159B 435 01	LGS-E-3580	NMB 35x1.5	42	6.0	109.4	188.4
48 x 5R/10R	R159B 465 01	LGS-E-65140	NMB 65x2	100	27.0	305.3	615.4

Suitable for screw ends: Form

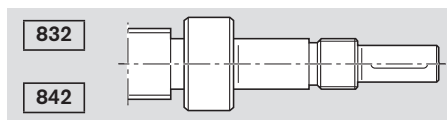

- C = dynamic load rating
 C₀ = static load rating
 d₀ x P = size
 d₀ = nominal diameter
 Nr. = part number
 P = lead (R = right-hand)

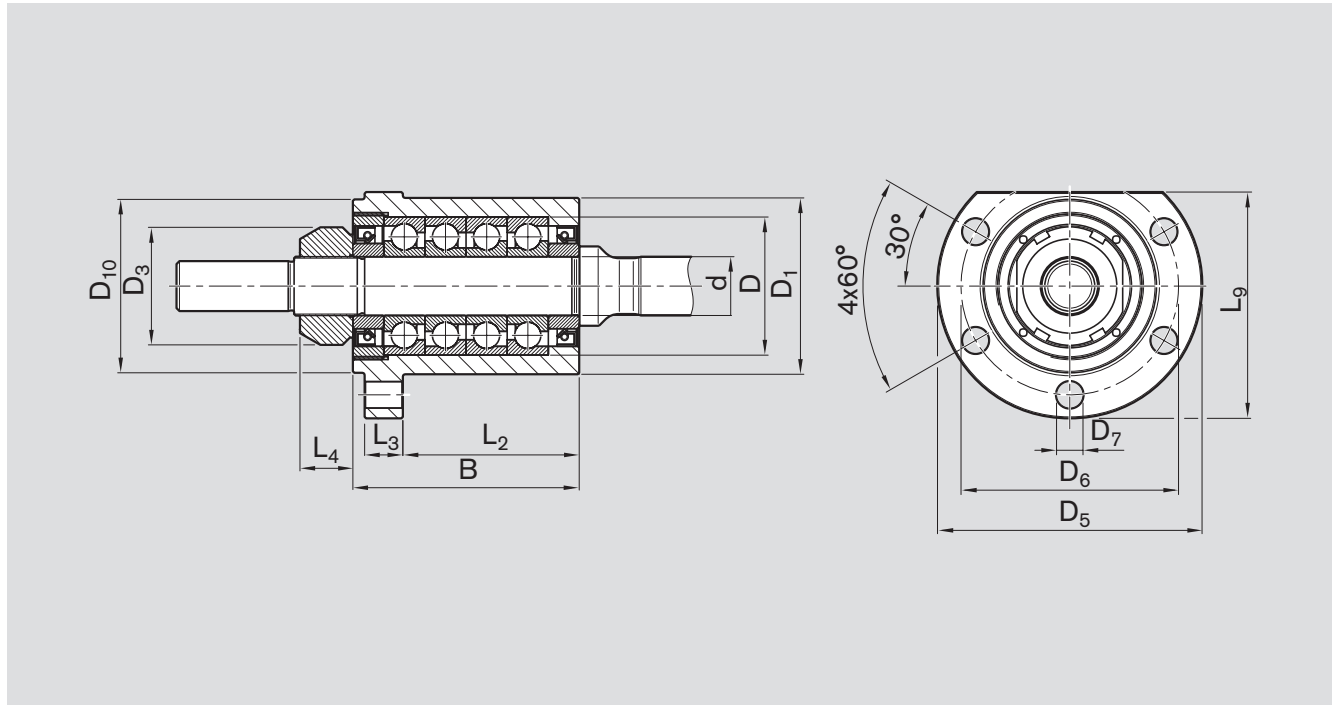

$d_0 \times P$	(mm)												
	d	D	B	L2	L3	L4	L9	D1 h7	D3	D5	D6	D7	D10
20 x 5R	25 _{-0.010}	62 _{-0.013}	89	68.0	16	20	104.0	80	44	120	100	11.0	80
30 x 5R/10R	35 _{-0.012}	80 _{-0.013}	110	82.0	20	22	124.0	100	54	140	120	13.0	99
48 x 5R/10R	65 _{-0.015}	140 _{-0.018}	180	133.5	30	28	199.5	170	95	225	198	17.5	170

Slotted Nuts and Housing Nuts

Slotted Nuts NMA for Fixed Bearings

Slotted nut NMA

– for maximum vibratory loads

M_A = tightening torque for slotted nut
 F_{aB} = axial breaking load of slotted nut
 M_{AG} = tightening torque for set screw
 Nr. = part number

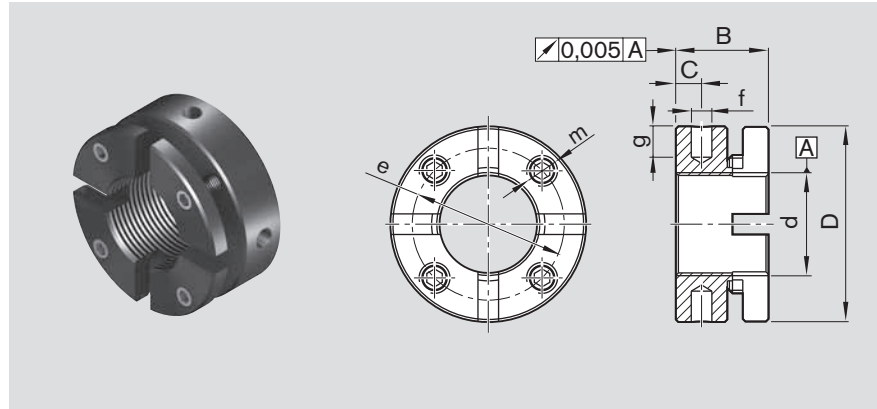

Designation	Nr.	(mm)								M_A (Nm)	F_{aB} (kN)	M_{AG} (Nm)	Weight (g)
		d	D	B	c	m	e	f	g				
NMA 15x1	R3446 020 04	M15x1	30	18	5	M5	24	4	5	10	100	3	60
NMA 17x1	R3446 014 04	M17x1	32	18	5	M5	26	4	5	15	120	3	70
NMA 20x1	R3446 015 04	M20x1	38	18	5	M6	31	4	6	18	145	5	130
NMA 25x1.5	R3446 011 04	M25x1.5	45	20	6	M6	38	5	6	25	205	5	160
NMA 30x1.5	R3446 016 04	M30x1.5	52	20	6	M6	45	5	7	32	250	5	200
NMA 35x1.5	R3446 012 04	M35x1.5	58	20	6	M6	51	5	7	40	280	5	230
NMA 40x1.5	R3446 018 04	M40x1.5	65	22	6	M6	58	6	8	55	350	5	300
NMA 50x1.5	R3446 019 04	M50x1.5	75	25	8	M6	68	6	8	85	450	5	430

Housing nut GWR

- for angular-contact thrust ball bearing LGN
- for cylindrical single nut ZEM-E-S

Note:

Use a threadlocker (e.g. Loctite 638) to secure against loosening.

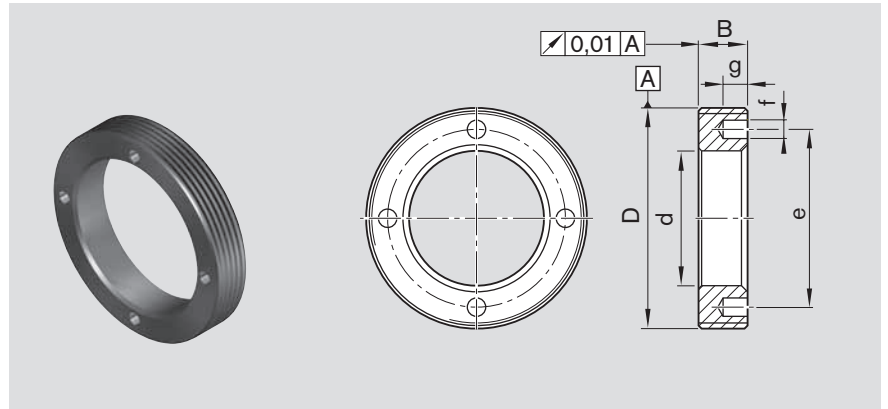

Designation	Nr.	(mm)						Weight (g)
		D	d	B	e	f	g	
GWR 18x1	R1507 040 33	M18x1	8.5	8	12.5	2.5	3	10.0
GWR 23x1	R1507 240 35	M23x1	13.0	8	18.0	2.5	3	15.0
GWR 26x1.5	R1507 240 22	M26x1.5	16.5	8	20.5	2.5	3	16.5
GWR 30x1.5	R1507 340 34	M30x1.5	17.0	8	23.0	3.0	4	29.0
GWR 36x1.5	R1507 040 23	M36x1.5	22.0	8	29.0	3.0	4	35.0
GWR 40x1.5	R1507 140 03	M40x1.5	25.0	8	33.0	3.0	4	39.5
GWR 45x1.5	R1507 240 04	M45x1.5	28.0	8	38.0	3.0	4	55.0
GWR 50x1.5	R1507 240 25	M50x1.5	31.0	10	40.0	4.0	5	86.0
GWR 55x1.5	R1507 340 05	M55x1.5	36.0	10	46.0	4.0	5	96.0
GWR 58x1.5	R1507 440 32	M58x1.5	43.0	10	50.0	4.0	5	84.0
GWR 60x1	R1507 440 28	M60x1	43.0	10	51.0	4.0	5	97.0
GWR 62x1.5	R1507 440 29	M62x1.5	43.0	12	53.0	5.0	6	127.0
GWR 65x1.5	R1507 440 26	M65x1.5	47.0	12	55.0	4.0	5	136.0
GWR 70x1.5	R1507 440 06	M70x1.5	42.0	12	58.0	4.0	5	216.0
GWR 78x2	R1507 540 07	M78x2	52.0	15	67.0	6.0	7	286.0
GWR 92x2	R1507 640 09	M92x2	65.0	16	82.0	6.0	7	385.0
GWR 112x2	R1507 740 11	M112x2	82.0	18	100.0	8.0	8	596.0

Technical Data

Technical Notes

The degree of efficiency determines the torque required to convert the rotary motion into linear motion.

Due to their high mechanical efficiency, PLSAs are in principle not self-locking.

⚠ Safety information

For installation, customers should check whether separate protection against falling loads, e.g. a safety nut, is required. Please consult us.

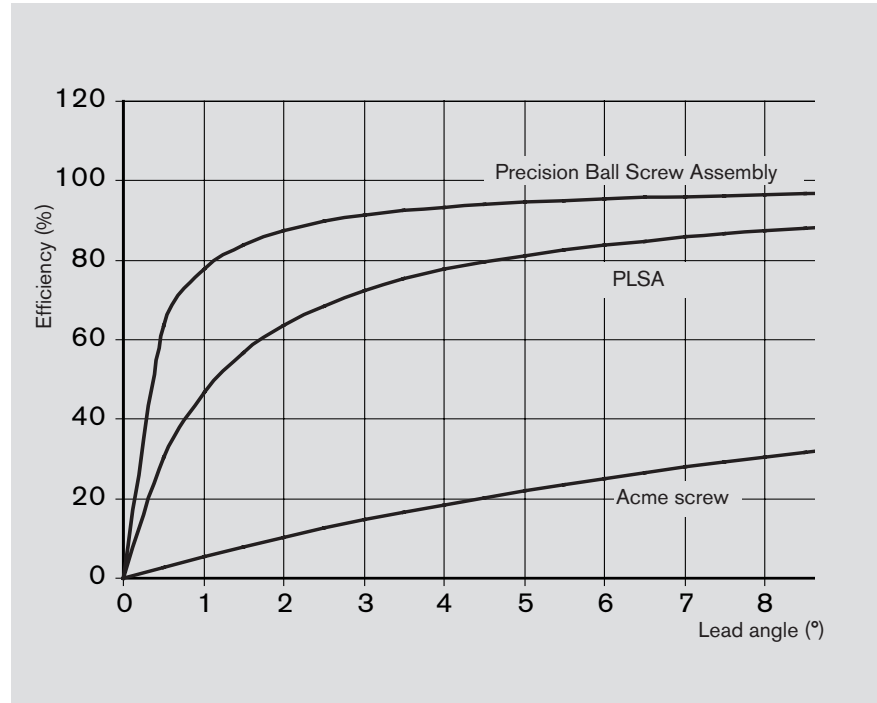

Advantages over the Acme screw drive

- The mechanical efficiency of an Acme screw drive is a maximum 50%, whereas a PLSA can reach a mechanical efficiency of up to 90%.
- Higher life expectancy due to negligible wear during operation
- Less drive power required
- No stick-slip effect
- More precise positioning
- Higher travel speed
- Less heat-up

Selection criteria for PLSAs (extract)

- The following factors should be considered when selecting the PLSA for a given application:
- degree of accuracy required (lead deviation)
 - in-service load conditions
 - service life
 - critical speed
 - buckling load
 - rigidity/permissible clearance or desired preload
 - characteristic speed (max. permissible linear speed)

⚠ Note

Radial and eccentric forces relative to the screw must be avoided, as they can affect the PLSA's performance and shorten its life. Where special conditions of use are involved, please ask.

The following points should be taken into consideration when selecting a PLSA that is to be both cost-efficient and optimally designed:

- The calculation of the service life should be based on average loads and average speeds, not on maximum values.
- In order for us to provide you with a customized solution, installation drawings or sketches of the nut environment should be enclosed with.

Static load rating C_0 The static load rating is an axial, concentrically acting force that induces a permanent deformation of $0.0001 \times$ the rolling element diameter.

Dynamic load rating C The dynamic load rating is an axial, concentrically acting force of constant magnitude and direction under which 90% of a sufficiently large number of identical PLSAs can achieve a nominal service life of one million revolutions.

Correction factor for tolerance grades The static load rating C_0 and the dynamic load rating C must be multiplied by the correction factor f_{ac} as appropriate for the specific tolerance grade of the screw.

Tolerance grade T	5	7	9
f_{ac}	1	0,9	0,8

Service life The nominal life is expressed by the number of revolutions (or number of operating hours at constant speed) that will be attained or exceeded by 90% of a representative sample of identical PLSA's before the first signs of material fatigue become evident. The nominal life is designated as L or L_n , depending on whether it is specified in revolutions or hours.
The nominal life calculation is based on optimal installation and environmental conditions. The service life may be shortened, for example, if the lubrication is affected by exposure to process media.

Critical speed and buckling load The critical speed and buckling load can be checked using the corresponding charts. For precise calculations see formula 12 15, in "Design Calculations".

Characteristic speed $d_0 \cdot n$ Rexroth PLSAs can be operated at very high speeds due to their structural design. Characteristic speeds of up to 150,000 are possible depending on the nut type.
 $d_0 \cdot n \leq 150\,000$
 d_0 = nominal diameter (mm)
 n = speed (min^{-1})
 The theoretically possible maximum linear speed v_{\max} (m/min) is specified on the page featuring the relevant nut. Actually attainable speeds are heavily dependent among other factors on preload and duty cycle. They are generally restricted by the critical speed. (See "Design Calculations").

Material, hardness PLSAs are made of high-quality, heat-treatable steel, carbon chrome alloy steels or case-hardened steels. The screw and nut raceways have a minimum Rockwell hardness of HRC 58. The screw ends are not hardened.

Technical Data

Technical Notes

Sealing

PLSAs are precision assemblies that require protection against contamination. Flat protective covers, bellows type dust boots or other enclosures are particularly suitable for this purpose. As there are many applications in which these methods do not provide sufficient protection, we have developed a gapless lip-type seal which ensures an optimal sealing effect and maintains high efficiency due to the low friction level. Our PLSAs are therefore supplied with seals in their standard versions. At the customer's request, these seals can be omitted. To ensure that seals retain their functionality, dirt must be removed at regular intervals.

Short stroke

Short stroke applications = stroke \leq nut length

Lubrication:

During a short stroke, the planets do not make a real turn. It is therefore impossible for an adequate lubricating film to form. This may result in premature wear. To avoid this, it is sufficient to perform longer strokes at regular intervals with simultaneous relubrication as "lubricating strokes".

Load rating:

Short stroke applications will increase the number of times a rolling load passes over each point within the load zone. This reduces the load rating. Please consult us.

Permissible operating temperature

PLSAs are suitable for continuous operation at temperatures up to 80 °C with temporary peaks of 100 °C (measurements taken on the outer shell of the nut).

Permissible operating temperatures:

$$- 10 \text{ °C} \leq T_{\text{operating}} \leq 80 \text{ °C}$$

Permissible bearing temperature:

$$- 15 \text{ °C} \leq T_{\text{bearing}} \leq 80 \text{ °C}$$

Acceptance Conditions and Tolerance Grades

Permissible travel deviation in accordance with DIN ISO 3408-3

Symbol definitions (excerpt):

- l_0 = nominal travel
- l_1 = thread length
- Δl_0 = travel deviation
- l_u = useful travel
- l_e = excess travel (the closer tolerances for travel and hardness do not apply here)
- c = travel compensation (target travel deviation) (standard: $c = 0$)
- e_p = tolerance mean actual travel deviation
- v_{300p} = permissible travel deviation within 300 mm travel
- $v_{2\pi p}$ = permissible travel deviation within one revolution

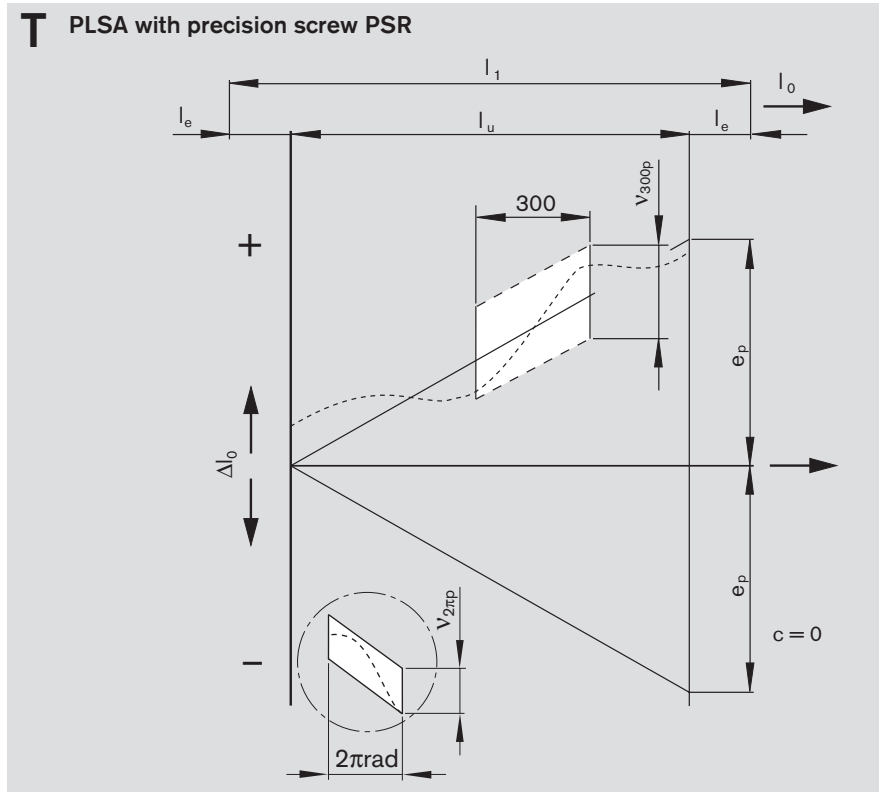

Useful travel l_u		tolerance mean actual travel deviation e_p (μm)		
$>$	\leq	Tolerance grade		
		5	7	9
0	100	18	44	110
100	200	20	48	120
200	315	23	52	130
315		$e_p = \frac{l_u}{300} \cdot v_{300p}$		

For precision screws PSR the following values apply in all cases:

v_{300p} (μm)		
Tolerance grade		
5	7	9
23	52	130

$v_{2\pi p}$ (μm)		
Tolerance grade		
5	7	9
8	10	10

Non-usable length l'_e
(Excess travel)

d_0 (mm)	l_e (mm)
20, 30	40
48	50

Minimum number of measurements within 300 mm (measuring interval) and excess travel to be taken into consideration.

Lead P (mm)	Minimum number of measurements for tolerance grade		
	5	7	9
5	6	3	3
10	3	1	1

Technical Data

Acceptance Conditions and Tolerance Grades

Run-outs and location deviations based on DIN ISO 3408-3

Radial run-out t_5 of the outer diameter of the screw over the length l_5 used to determine the straightness in relation to AA'.

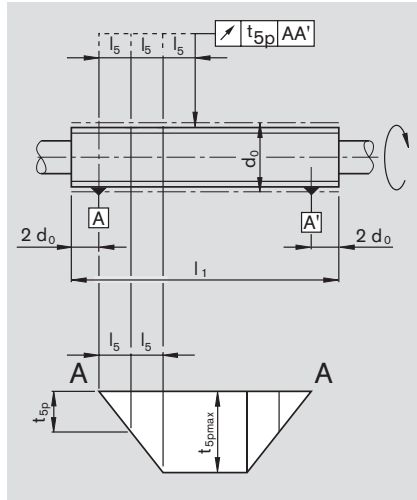

d_0		l_5	t_{5pmax} in μm for l_5 tolerance grade	
>	\leq		5	7; 9
6	12	80	32	40
12	25	160		
25	50	315		
50	100	630		
100	200	1250		

l_1/d_0		t_{5pmax} in μm for $l_1 \geq 4l_5$ tolerance grade	
>	\leq	5	7; 9
	40	64	80
40	60	96	120
60	80	160	200
80	100	256	320

Radial run-out t_6 of the bearing diameter in relation to AA' for $l_6 \leq l$.
Table value t_{6p} applies when $l_6 \leq$ reference length l .

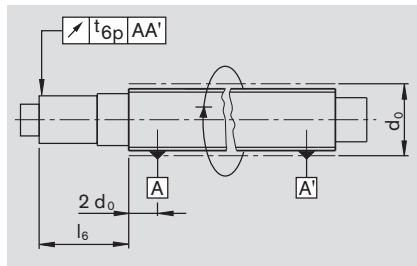

d_0		Reference length l	t_{6p} in μm for $l_6 \leq l$ tolerance grade	
>	\leq		5	7; 9
6	20	80	20	40
20	50	125	25	50
50	125	200	32	63
125	200	315	40	80

Where $l_6 > l$ then $t_{6a} \leq t_{6p} \cdot \frac{l_6}{l}$

Coaxial deviation t_7' of the journal diameter of the screw shaft in relation to the bearing diameter for $l_7 > l$.

Table value t_{7p} applies when $l_7 \leq$ reference length l .

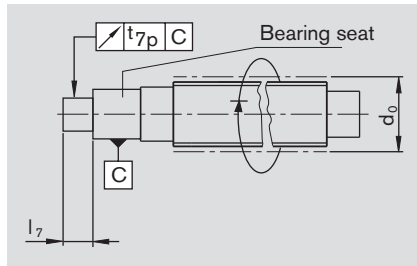

d_0		Reference length l	t_{7p} in μm for $l_7 \leq l$ tolerance grade	
>	\leq		5	7; 9
6	20	80	8	12
20	50	125	10	16
50	125	200	12	20
125	200	315	16	25

Where $l_7 > l$ then $t_{7a} \leq t_{7p} \cdot \frac{l_7}{l}$

d_0 = nominal diameter

Axial run-out t_{8p} of the shaft (bearing) face of the screw shaft in relation to the bearing diameter.

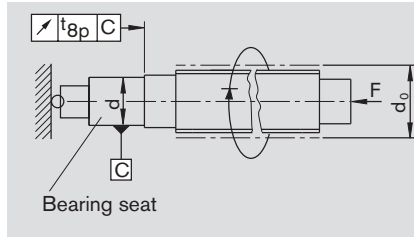

d_0	t_{8p} in μm for tolerance grade			
	>	\leq	5	7; 9
6	63		5	6
63	125		6	8
125	200		8	10

Axial run-out t_{9p} of the nut location face in relation to **A** and **A'** (for preloaded nuts only).

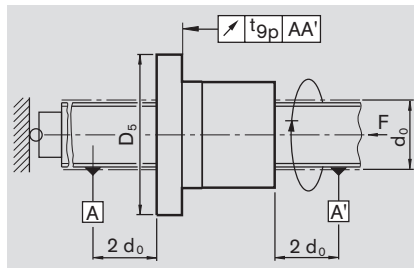

Flange diameter D_5	t_{9p} in μm for tolerance grade			
	>	\leq	5	7; 9
16	32		16	20
32	63		20	25
63	125		25	32
125	250		32	40
250	500		40	50

Radial run-out t_{10p} of the outer diameter D_1 of the nut in relation to **A** and **A'** (for preloaded and rotating nuts only). Fix screw against rotation before carrying out the measurement.

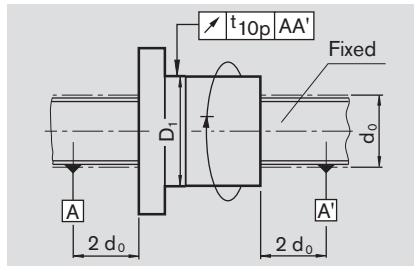

Outer diameter D_1	t_{10p} in μm for tolerance grade			
	>	\leq	5	7; 9
16	32		16	20
32	63		20	25
63	125		25	32
125	250		32	40
250	500		40	50

Technical Data

Preload, Rigidity, Friction Torques

Nut system preload

In addition to single nuts with reduced backlash, Rexroth supplies preloaded nut systems.

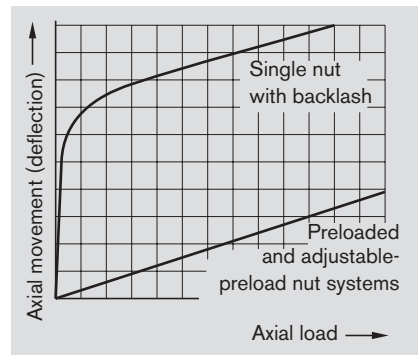

With preloaded nut systems, the deformation due to load cycling is significantly less than that of systems without preload. Preloaded nut systems should therefore be used in applications requiring a high degree of rigidity. The screw is typically far less rigid than the nut unit (for details see “Overall axial rigidity...”).

Rigidity

The rigidity of a PLSA is also influenced by all adjoining parts such as bearings, housing bores, nut housings etc.

Overall axial rigidity R_{bs} of the PLSA

The overall axial rigidity R_{bs} is comprised of the component rigidity of the bearing R_{fb} , the screw R_S and the nut unit R_{nu} .

$$\frac{1}{R_{bs}} = \frac{1}{R_{fb}} + \frac{1}{R_S} + \frac{1}{R_{nu}} \quad 16$$

Rigidity of the bearing R_{fb}

The rigidity of the bearings corresponds to the values found in the bearing manufacturer's catalog. See the corresponding tables in this catalog for rigidity values of the bearings offered by Rexroth.

Rigidity of the screw R_S

The rigidity of the screw R_S depends on the type of bearing used. See the corresponding tables for rigidity values.

Note:

Please note that in most cases the rigidity R_S of the screw will be significantly lower than the rigidity R_{nu} of the nut unit.

1 PLSA shaft is fixed at one end.

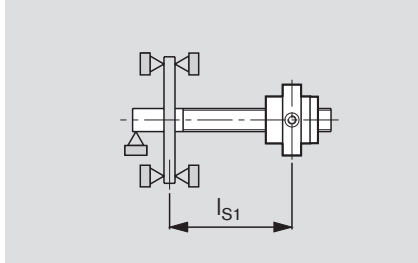

$$R_{S2} = 165 \cdot \frac{(d_0)^2}{l_{S2}} \cdot \frac{l_S}{l_S - l_{S2}} \quad (\text{N}/\mu\text{m}) \quad 18$$

$$R_{S1} = 165 \cdot \frac{(d_0)^2}{l_{S1}} \quad (\text{N}/\mu\text{m}) \quad 17$$

2 PLSA shaft is fixed at both ends.

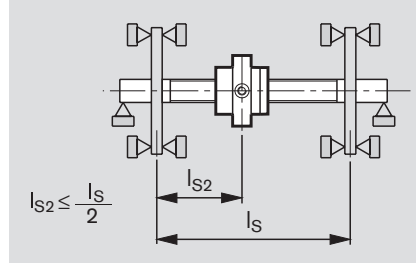

The lowest screw rigidity R_{S2min} occurs at the center of the screw ($l_{S2} = l_S/2$) and thus equals:

$$R_{S2min} = 660 \cdot \frac{(d_0)^2}{l_S} \quad (\text{N}/\mu\text{m}) \quad 19$$

$R_S/R_{S1}/R_{S2}$ = rigidity of the screw (N/μm)
 d_0 = nominal diameter (mm)
 l_S = distance between bearing and bearing (mm)
 l_{S2} = distance between bearing and nut (mm)

Rigidity in the area of the nut unit R_{nu}

See the corresponding tables for rigidity values.

Dynamic drag torque, preload and rigidity for screws

$d_0 \times P$	Backlash of single nut FEM / ZEM standard (mm)	Preload of flanged single nut, split FDM			
		R_{nu} (N/μm) max.	T_{pr0} (Nm) max.	R_S (N·m/μm)	T_{RD} approx. (Nm)
20 x 5	0,03	400	0.58	66	0.10
30 x 5		620	1.13	148	0.15
30 x 10		420	1.13	148	0.15
48 x 5		1080	2.47	380	0.50
48 x 10		760	2.47	380	0.50

The values given for dynamic drag torque are proven practical indicators for the nut preloading.

- $d_0 \times P$ = Size
- R_S = Rigidity of the screw
- R_{nu} = Rigidity of the nut unit
- T_{RD} = Dynamic drag torque of the 2 seals
- T_{pr0} = Dynamic drag torque without seals
- T_0 = Overall dynamic drag torque
- $T_0 = T_{pr0} + T_{RD}$

Mounting

Mounting

Condition as delivered

Rexroth PLSAs are normally delivered with an initial supply of grease. Relubrication is possible, and cartridges and cans of this grease are available. If another lubricant is used, you will need to check that it is compatible with the initial supply.

For special cases, the PLSAs can also be supplied with only a preservative coating. This can be indicated by choosing the appropriate option number in the ordering code.

Important

The selected lubricant must be in the nut before the machine is started.

Cleaning

Various cleaning agents can be used to degrease and wash the assembly:

- aqueous cleaning agents
- organic cleaning agents

Important

Immediately after cleaning, thoroughly dry all parts, then apply a preservative coating or anti-corrosion oil. In all cases, take care to observe the appropriate legal regulations (environmental protection, health and safety at work, etc.) as well as the specifications for the cleaning agent (e.g. handling).

Storage

PLSAs are high-quality systems that must be treated with due care. In order to prevent damage and contamination, the elements should not be removed from the protective wrapping until immediately before installation. Once they have been removed from the packaging, they must be set down on V-shaped cradles.

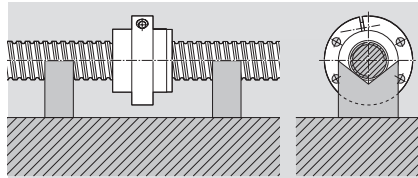

Installation in the machine

It is not normally necessary to remove the preservative coating before installation.

- If the PLSA is contaminated it must first be cleaned (see “Cleaning”) and re-oiled
- Push the nut unit into the mounting bore, taking care to avoid any impact force or misalignment.
- Tighten the mounting screws using a torque wrench if necessary. Maximum tightening torque for the steel/steel material pairing ($R_m \geq 370 \text{ N/mm}^2$), see table.
- For the steel/aluminum and aluminum/aluminum material pairings ($R_m \geq 280 \text{ N/mm}^2$) the maximum tightening torques specified in the follow table apply.

When driving screws into aluminum, the length of thread engagement should be at least 1.5 times the screw diameter.

Tightening torques for fastening screws according to VDI 2230 for $\mu_G = \mu_K = 0.125$

Screw diameter (mm)	Tightening torque (Nm)		
	Strength class per DIN ISO 898:		
	8.8	10.9	12.9
M3	1.2	1.2	1.2
M4	2.4	2.4	2.4
M5	4.8	4.8	4.8
M6	8.5	8.5	8.5
M8	20.0	20.0	20.0
M10	41.0	41.0	41.0
M12	70.0	70.0	70.0
M14	110.0	110.0	110.0
M16	175.0	175.0	175.0
M18	250.0	250.0	250.0
M20	345.0	345.0	345.0

Screw diameter (mm)	Tightening torque (Nm)		
	Strength class per DIN ISO 898:		
	8.8	10.9	12.9
M3	1.3	1.8	2.1
M4	2.7	3.8	4.6
M5	5.5	8.0	9.5
M6	9.5	13.0	16.0
M8	23.0	32.0	39.0
M10	46.0	64.0	77.0
M12	80.0	110.0	135.0
M14	125.0	180.0	215.0
M16	195.0	275.0	330.0
M18	280.0	400.0	470.0
M20	390.0	560.0	650.0

Alignment of the PLSA in the machine

Self-aligning contact pads for easy alignment of the PLSA are available from Rexroth. (pads fitting for standard gauge).

Two pads of different lengths are available, which can be used depending on the screw lead:

- Part number R3305 131 19: length 33 mm
- Part number R3305 131 21: length 50 mm

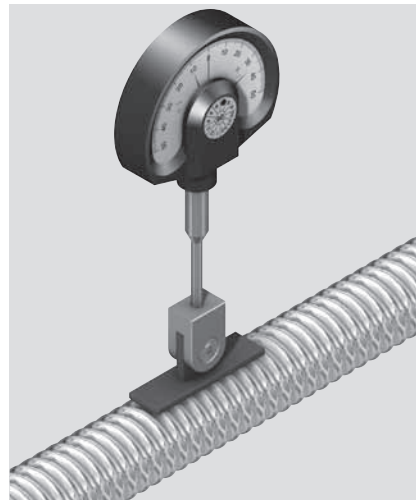

End Bearings

Design Notes, Mounting Instructions

Bearing design

For customer-machined screw ends, please consider the design notes given for screw ends and housings.

For Rexroth screw end designs, see "End Machining Details."

Rexroth delivers complete drive systems, including the end bearings. Calculations are performed with the formulas used in the antifriction bearing industry.

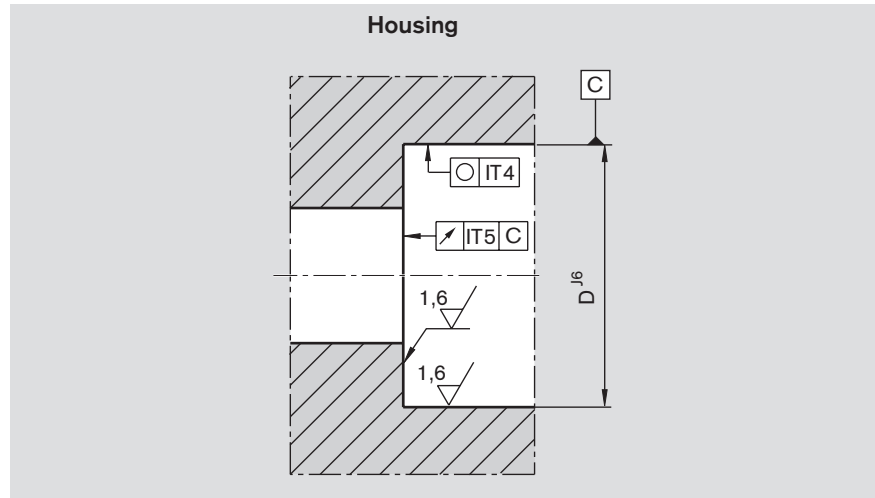

Mounting

Angular-contact thrust ball bearings and deep-groove ball bearings

When mounting the angular-contact thrust ball bearings LGF and LGN, ensure that the mounting forces are exerted only on the bearing rings. Never apply mounting forces via the anti-friction bearing elements or the seal rings! The two sections of the inner raceway may not be separated during assembly or disassembly for any reason! Tighten the mounting screws for screw-down or flange-mounted bearings in crosswise sequence. The mounting screws may be

subjected only to tension amounting to a maximum of 70% of their yielding point. The screw-down (LGF) bearings have a groove on the cylindrical surface of the outer raceway for disassembly. The individual bearings of the bearing pair series LGF-C... and LGN-C... are marked on the cylindrical surfaces of the outer raceways (see Figure). The markings reveal the bearing sequence. The sealing rings should face outward after proper mounting.

Outer raceway markings for paired bearings

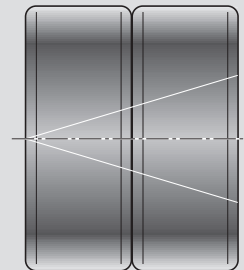

Slotted nut NMA, NMZ

The bearings are preloaded by tightening the nuts.

In order to prevent settling phenomena, we recommend first tightening the slot-ted nut by twice the value of the tightening torque M_A and then easing the load. Only then should the slotted nut be retightened to the specified tightening

torque M_A . The two set screws are then alternately tightened using a hexagon socket wrench.

The components are disassembled in the reverse order, i.e. the set screws are to be removed before the slotted nut. The slotted nuts can be used several times when properly assembled and

disassembled by competent personnel. The inner raceways of the bearings are dimensioned in such a way as to achieve a defined bearing preload sufficient for most applications when the slotted nut is tightened (M_A in accordance with Dimension Table).

Lubrication

Lubrication

Grease lubrication

Planetary Screw Assemblies (PLSAs) are designed for lubrication with NLGI class 2 greases. The advantage of grease lubrication is that the PLSA can run long distances on one supply of grease.

⚠ Do not use greases containing solid particles (e.g., graphite or MoS₂)!

⚠ If other lubricants are used, this may lead to a reduction in the relubrication intervals, the achievable travel in short-stroke applications, and the load ratings. Possible chemical interactions between the plastic materials, lubricants and preservative oils must also be taken into account.

⚠ If your application involves more demanding environmental requirements (such as clean room, vacuum, food industry environment, increased exposure to fluids or aggressive media, extreme temperatures), please consult us. These situations must be investigated on a case by case basis and may require the use of a special lubricant. Be sure to have all the information concerning your application at hand when contacting us.

⚠ For certain areas of use, e.g. food industry, clean room, vacuum applications, etc. or conditions such as extreme temperatures or exposure to processing media, the standard in-factory prelubrication and anticorrosive treatment may not be suitable or may not be compatible with the lubricant used for in-service lubrication. Please check suitability with us first!

⚠ Even under normal operating conditions, the system must be relubricated at the latest after 2 years due to aging of the grease. The seals on the PLSA nut must be coated with the relevant lubricant before installation to ensure that they are not dry during start-up, which would cause them to wear out faster.

Grease lubrication quantities for NLGI 2 greases

Standard lubrication practices for ball bearings also apply to Planetary Screw Assemblies. Lubricant loss is, however, greater than that from conventional ball bearings, for instance, due to the axial motion between the screw and the nut.

The nut has to be lubricated with grease via the lube port before the PLSA is started. We recommend the following grease lubricants for standard applications: Dynalub 510, Elkalub GLS 135/N 2, or Castrol Longtime PD 2.

d ₀ x P	Lubricant quantities (cm ³)	
	Initial lubrication V _e	Relubrication V _n
20 x 5	10	5
30 x 5	20	10
30 x 10	20	10
48 x 5	50	25
48 x 10	50	25

Dynalub high-performance lubricant for linear motion technology

(approved for the EU only)

The product specifications and safety data sheet and other technical data for Dynalub can be found at www.boschrexroth.de/brl

Product description, Dynalub 510

Application area

Under conventional environmental conditions this ground-fiber, homogeneous grease is ideally suited for the lubrication of linear elements.

Part number	Packing unit
R3416 037 00	1 x 400 g
R3416 035 00	25 kg

Design Calculations

Upon request, we can perform all calculations to your specifications.

Average speed and average load

- where the speed fluctuates, the average speed n_m is calculated as follows:

See “Design Calculation Service Form”, page 58

Where the speed and load fluctuate, the service life must be calculated using the averages F_m and n_m .

$$n_m = \frac{|n_1| \cdot q_{t1} + |n_2| \cdot q_{t2} + \dots + |n_n| \cdot q_{tn}}{100\%} \quad 1$$

n_1, n_2, \dots, n_n = speeds in phases 1 ... n (min⁻¹)
 n_m = average speed (min⁻¹)
 $q_{t1}, q_{t2}, \dots, q_{tn}$ = discrete time step in phases 1 ... n (%)

The following applies for the effective equivalent bearing load:

Preload class factor X_{pr} : 0.03

$$F > 2,8 \cdot X_{pr} \cdot C \quad F_{eff\ n} = |F_n|$$

$$F \leq 2,8 \cdot X_{pr} \cdot C \quad F_{eff\ n} = \left[\frac{|F_n|}{2,8 \cdot X_{pr} \cdot C} + 1 \right]^{\frac{3}{2}} \cdot X_{pr} \cdot C$$

C = dynamic load rating (N)
 $F_{eff\ n}$ = effective equivalent axial load during phase n (N)
 F_n = axial load during phase n (N)
 X_{pr} = preload factor (-)

- where the load fluctuates and the speed is constant, the average load F_m is calculated as follows:

$$F_m = \sqrt[3]{|F_{eff\ 1}|^3 \cdot \frac{q_{t1}}{100\%} + |F_{eff\ 2}|^3 \cdot \frac{q_{t2}}{100\%} + \dots + |F_{eff\ n}|^3 \cdot \frac{q_{tn}}{100\%}} \quad 2$$

$F_{eff\ 1}, F_{eff\ 2}, \dots, F_{eff\ n}$ = effective equivalent axial load during phases 1 ... n (N)
 F_m = equivalent dynamic axial load (N)
 $q_{t1}, q_{t2}, \dots, q_{tn}$ = discrete time step for $F_{eff\ 1}, \dots, F_{eff\ n}$ (%)

- where both the load and the speed fluctuate, the average load F_m is calculated as follows:

$$F_m = \sqrt[3]{|F_{eff\ 1}|^3 \cdot \frac{|n_1|}{n_m} \cdot \frac{q_{t1}}{100\%} + |F_{eff\ 2}|^3 \cdot \frac{|n_2|}{n_m} \cdot \frac{q_{t2}}{100\%} + \dots + |F_{eff\ n}|^3 \cdot \frac{|n_n|}{n_m} \cdot \frac{q_{tn}}{100\%}} \quad 3$$

$F_{eff\ 1}, F_{eff\ 2}, \dots, F_{eff\ n}$ = effective equivalent axial load during phases 1 ... n (N)
 F_m = equivalent dynamic axial load (N)
 n_1, n_2, \dots, n_n = speeds during phases 1 ... n (min⁻¹)
 n_m = average speed (min⁻¹)
 $q_{t1}, q_{t2}, \dots, q_{tn}$ = discrete time step for $F_{eff\ 1}, \dots, F_{eff\ n}$ (%)

Nominal life

Service life in revolutions L

$$L = \left[\frac{C}{F_m} \right]^3 \cdot 10^6 \quad 4 \Rightarrow C = F_m \cdot \sqrt[3]{\frac{L}{10^6}} \quad 5 \Rightarrow F_m = \frac{C}{\sqrt[3]{\frac{L}{10^6}}} \quad 6$$

C = dynamic load rating (N)

F_m = equivalent dynamic axial load (N)

L = service life in revolutions (-)

Service life in hours L_h

$$L_h = \frac{L}{n_m \cdot 60} \quad 7$$

L_h = service life (h)

L = service life in revolutions (-)

n_m = average speed (min⁻¹)

$$L_{h \text{ machine}} = L_h \cdot \frac{DC_{\text{machine}}}{DC_{\text{PLSA}}} \quad 8$$

DC_{machine} = duty cycle of the machine (%)DC_{PLSA} = duty cycle of the PLSA (%)L_{h machine} = nominal service life of the machine (h)L_h = nominal service life of the PLSA (h)**Drive torque and drive power****Drive torque M_{ta}**

for conversion of rotary motion into linear motion:

$$M_{ta} = \frac{F_L \cdot P}{2000 \cdot \pi \cdot \eta} \quad 9$$

F_L = thrust force (N)M_p = maximum permissible drive torque (Nm)

$$M_{ta} \leq M_p$$

M_{ta} = drive torque (Nm)

P = lead (mm)

η = mech. efficiency (approx. 0.8) (-)

Transmitted torque M_{te}

for conversion of linear motion into rotary motion:

$$M_{te} = \frac{F_L \cdot P \cdot \eta'}{2000 \cdot \pi} \quad 10$$

F_L = thrust force (N)M_p = maximum permissible drive torque (Nm)

$$M_{te} \leq M_p$$

M_{te} = transmitted torque (Nm)

P = lead (mm)

η' = mech. efficiency (η' approx. 0.7) (-)

The dynamic drag torque must be taken into account for preloaded nuts.

Drive power P_a

$$P_a = \frac{M_{ta} \cdot n}{9550} \quad 11$$

M_{ta} = drive torque (Nm)n = speed (min⁻¹)P_a = drive power (kW)

Design Calculations

Design Calculations

Calculation example
Service life

Operating conditions

The service life of the machine should be 40,000 operating hours with the PLSA operating 60% of the time.

Proposed PLSA: 30 x 5, tolerance grade T5

$F_1 = 50\,000\text{ N}$	at	$n_1 = 10\text{ min}^{-1}$	for	$q_1 = 6\%$	of the duty cycle
$F_2 = 25\,000\text{ N}$	at	$n_2 = 30\text{ min}^{-1}$	for	$q_2 = 22\%$	of the duty cycle
$F_3 = 8\,000\text{ N}$	at	$n_3 = 100\text{ min}^{-1}$	for	$q_3 = 47\%$	of the duty cycle
$F_4 = 2\,000\text{ N}$	at	$n_4 = 1\,000\text{ min}^{-1}$	for	$q_4 = \frac{25\%}{100\%}$	of the duty cycle

Calculation procedure

Average speed n_m

$$n_m = \frac{6}{100} \cdot |10| + \frac{22}{100} \cdot |30| + \frac{47}{100} \cdot |100| + \frac{25}{100} \cdot |1000| \quad 1$$

$$n_m = 304\text{ min}^{-1}$$

Average load F_m for variable load and variable speed

$$F_m = \sqrt[3]{50000^3 \cdot \frac{|10|}{304} \cdot \frac{6}{100} + 25000^3 \cdot \frac{|30|}{304} \cdot \frac{22}{100} + 8000^3 \cdot \frac{|100|}{304} \cdot \frac{47}{100} + 2000^3 \cdot \frac{|1000|}{304} \cdot \frac{25}{100}} \quad 3$$

$$F_m = 8757\text{ N}$$

Required service life L
(revolutions)

The service life L can be calculated by transposing the formulas 7 and 8:

$$L = L_h \cdot n_m \cdot 60$$

$$L_h = L_{h\text{ machine}} \cdot \frac{DC_{PLSA}}{DC_{\text{machine}}}$$

$$L_h = 40000 \cdot \frac{60}{100} = 24000\text{ h}$$

$$L = 24000 \cdot 304 \cdot 60$$

$$L = 437\,760\,000\text{ revolutions}$$

Basic dynamic load rating C

$$C = 8757 \cdot \sqrt[3]{\frac{437\,760\,000}{10^6}} \quad 5 \quad C \approx 66492\text{ N}$$

Result and selection

The PLSA can now be selected from the Dimension Tables:

e.g. PLSA, size 30 x 5 R, with flanged single nut FEM-E-S, and screw in tolerance grade T5
Dynamic load rating $C = 87 \text{ KN}$.

Note:

Take into account the dynamic load rating of the screw end bearing used!
Consider the correction factor for the tolerance grade!

Cross check

Service life of the selected PLSA in revolutions

$$L = \left(\frac{87\,000}{8757} \right)^3 \cdot 10^6 \quad 4$$

$$L \approx 981 \cdot 10^6 \text{ revolutions}$$

Service life in hours L_h

$$L_h = \frac{981 \cdot 10^6}{304 \cdot 60} \quad 7$$

$$L_h \approx 57\,761 \text{ hours}$$

The life of the selected PLSA assembly is thus greater than the required service life of 24,000 hours (including operating hours).

Design Calculations

Critical speed n_{cr}

The critical speed n_{cr} depends on the diameter of the screw, the type of end fixity and the free length l_{cr} .

No allowance must be made for guidance by a nut without preload. The operating speed should not reach more than 80% of the critical speed.

The characteristic speed and the max. permissible linear speed must be taken into account, see "Technical Notes".

Example

Screw diameter = 63 mm
 Length l_{cr} = 1200 mm
 End fixity II (fixed bearing - floating bearing)

According to the graph, the critical speed is 3900 min^{-1} .
 The permissible operating speed is thus 3900 $min^{-1} \times 0.8 = 3120 \text{ min}^{-1}$.

The maximum operating speed in our calculation example of $n_4 = 1000 \text{ min}^{-1}$ is therefore below the permissible operating speed.

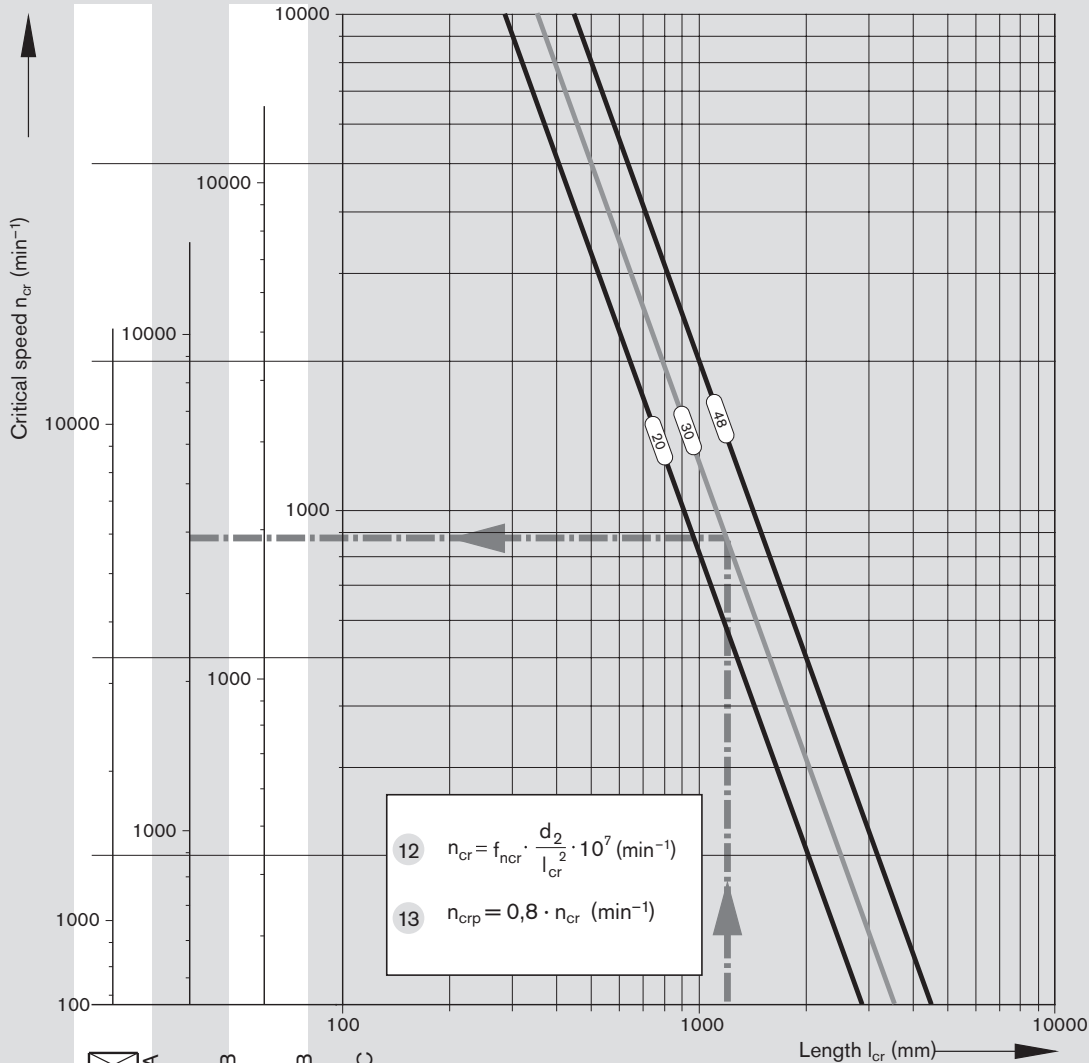

End fixity:

- A = fixed bearing
- B = floating bearing
- C = without bearing

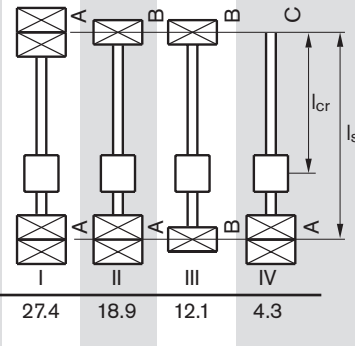

- n_{cr} = critical speed (min^{-1})
- n_{crp} = permissible operating speed (min^{-1})
- f_{ncr} = corrector value determined by bearing
- d_2 = root diameter (see Dimension Tables) (mm)
- l_{cr} = critical length for preloaded nut systems (mm)
- l_s = distance between bearing and bearing (mm)

For non-preloaded nut systems $l_{cr} = l_s$
 For screw ends form 312 the end fixity can be assumed to be "fixed".

Permissible axial load on screw F_c (buckling load)

The permissible axial load on the screw F_c depends on the diameter of the screw, the type of end fixity and the

effective free (unsupported) length l_c . A safety factor of $s \geq 2$ should be taken into consideration when determining the permissible axial load.

This therefore lies above the maximum operating load of $F_1 = 50 \text{ kN}$ used in our calculation example.

Example

Screw diameter = 30 mm,
 Length l_c = 1200 mm
 End fixity IV (fixed bearing - floating bearing)

According to the graph, the theoretically permissible axial load is 115 kN.
 A permissible axial load on the screw of $115 \text{ kN} / 2 = 57.5 \text{ kN}$ is achieved when applying the safety factor 2.

14 $F_c = f_{Fc} \cdot \frac{d_2^4}{l_c^2} \cdot 10^4 \text{ (N)}$

15 $F_{cp} = \frac{F_c}{2} \text{ (N)}$

F_c = theoretically permissible axial load on screw
 F_{cp} = permissible axial load during operation
 f_{Fc} = corrector value determined by bearing
 d_2 = root diameter (mm), see Dimension Tables
 l_c = unsupported threaded length (mm)

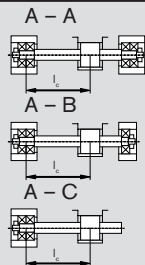
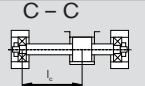
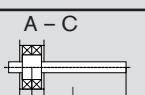
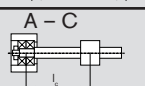
End fixity	f_{Fc} - value	
	nut fixed	nut lose
 End fixity I 40,6		End fixity IV 20,4
 End fixity II / IV 20,4		End fixity V 10,2
 End fixity III / VI 2,6		
 End fixity VI 2,6		

End fixity:

A = fixed bearing
 B = floating bearing
 C = without bearing

f_{Fc} - value	End fixity
2.6	III / VI
10.2	V
20.4	II / IV
40.6	I

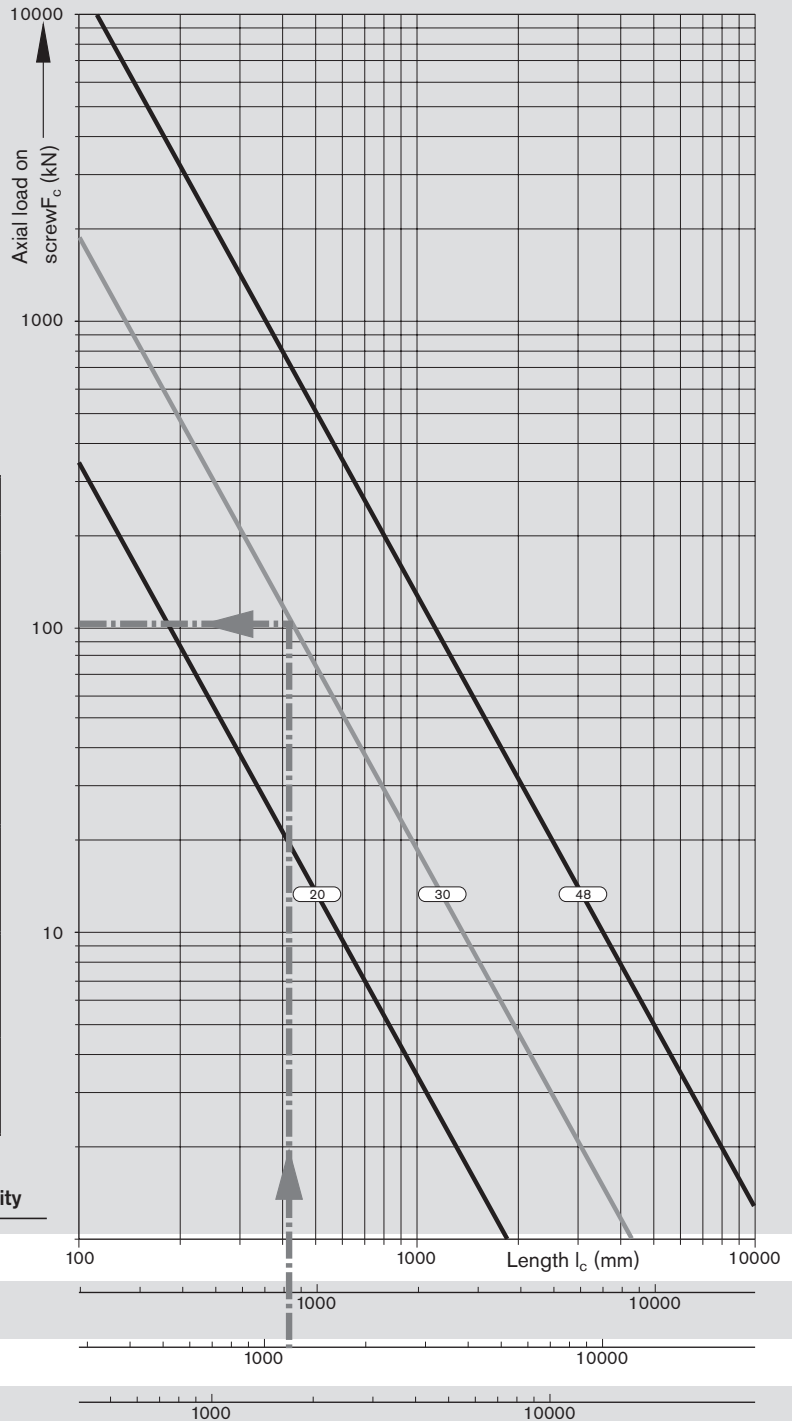

End Bearings

Design Calculations

Resulting and equivalent bearing loads

For angular-contact thrust ball bearings LGN and LFG

Angular-contact thrust ball bearings are preloaded. The chart shows the resulting axial bearing load F_{ax} as a function of preload and axial operating load F_{Lax} . For a purely axial load $F_{comb} = F_{ax}$.

$\alpha = 60^\circ$	X	Y
$\frac{F_{ax}}{F_{rad}} \leq 2.17$	1.90	0.55
$\frac{F_{ax}}{F_{rad}} > 2.17$	0.92	1.00

- α = pressure angle
- F_{ax} = resulting bearing load
- F_{Lax} = operating load
- X, Y = dimensionless factor

If the radial operating forces are not insignificant, the equivalent bearing loads are calculated according to formula 20.

Bearings for PLSAs are also able to accommodate tilting moments. As a rule, the moments that usually occur due to the weight and drive motion of the screw do not need to be incorporated in the calculation of the equivalent bearing load.

Permissible static axial load for bearing series LGF

The permissible static axial load of LGF-series bearings in screw-down direction is:

$$F_{comb} = X \cdot F_{rad} + Y \cdot F_{ax} \quad 20$$

- F_{ax} = resulting axial bearing load (N)
- F_{comb} = combined equivalent bearing load (N)
- F_{rad} = radial bearing load (N)

Internal preload limit and resulting bearing load

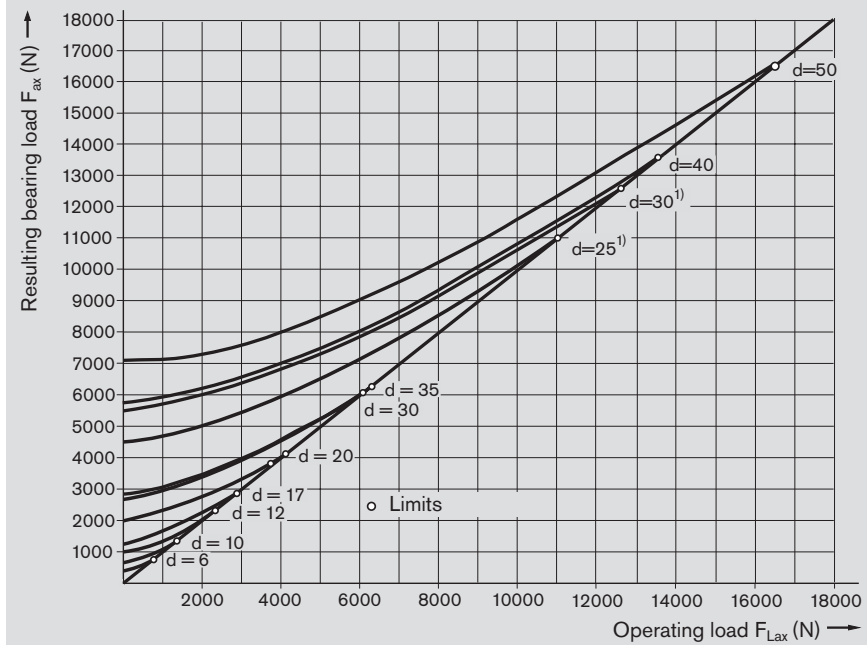

¹⁾ Four row version

$$F_{0ax p} \leq \frac{C_0}{2}$$

- $F_{0ax p}$ = permissible static axial bearing load (N)

The static axial load rating C_0 is stated in the Dimension Tables.

Average speed and average bearing load

When the bearing load varies in steps over a specific period of time, calculate the dynamic equivalent bearing load using formula 22.

When the speed varies, use formula 23. In these formulas q_t denotes the discrete time steps for the individual phases in %.

$$F_m = \sqrt[3]{F_{\text{comb}1}^3 \cdot \frac{|n_1|}{n_m} \cdot \frac{q_{t1}}{100} + F_{\text{comb}2}^3 \cdot \frac{|n_2|}{n_m} \cdot \frac{q_{t2}}{100} + \dots + F_{\text{comb}n}^3 \cdot \frac{|n_n|}{n_m} \cdot \frac{q_{tn}}{100}} \quad 22$$

$$n_m = \frac{q_{t1}}{100} \cdot |n_1| + \frac{q_{t2}}{100} \cdot |n_2| + \dots + \frac{q_{tn}}{100} \cdot |n_n| \quad 23$$

$F_{\text{comb}1} \dots F_{\text{comb}n}$	= combined equivalent axial load in phases 1 ... n	(N)
F_m	= dynamic equivalent bearing load	(N)
$n_1 \dots n_n$	= speeds in phases 1 ... n	(min ⁻¹)
n_m	= average speed	(min ⁻¹)
$q_{t1} \dots q_{tn}$	= discrete time steps in phases 1 ... n	(%)

Service life and load safety factor

Nominal life

The nominal life is calculated as follows:

Note:

Take into account the dynamic load rating of the nut!

$$L = \left(\frac{C}{F_{\text{comb}}} \right)^3 \cdot 10^6 \quad 24$$

$$L_h = \frac{16666}{n_m} \left(\frac{C}{F_{\text{comb}}} \right)^3 \quad 25$$

C	= dynamic bearing load rating	(N)
F_{comb}	= combined equivalent bearing load	(N)
L	= nominal service life in revolutions	(-)
L_h	= nominal service life in operating hours	(h)
n_m	= average speed	(min ⁻¹)

Static load safety factor

The static load safety factor for machine tools should not be lower than 4.

$$S_0 = \frac{C_0}{F_{0\text{max}}} \quad 26$$

$F_{0\text{max}}$	= maximum static load	(N)
C_0	= static load rating	(N)
S_0	= static load safety factor	(-)

Design Calculation Service Form

Bosch Rexroth AG
 Linear Motion and
 Assembly Technologies
 97419 Schweinfurt / Germany

Find your local contact person here:
www.boschrexroth.com/addresses

Application: New design Revised design

Operating conditions

Loads (N)	Speeds (1/min)	Discrete time steps (%)
$F_1 =$	at $n_1 =$	for $q_1 =$
$F_2 =$	at $n_2 =$	for $q_2 =$
$F_3 =$	at $n_3 =$	for $q_3 =$
$F_4 =$	at $n_4 =$	for $q_4 =$
$F_5 =$	at $n_5 =$	for $q_5 =$
$F_6 =$	at $n_6 =$	for $q_6 =$
Average load (see page 57)	Average speed (see page 57)	Sum of time steps
$F_m =$	$n_m =$	$Q = 100\%$
Maximum static load:	N	
Required service life	Operating hours or	$\times 10^6$ PLSA revolutions

Screw end fixity: horizontal vertical

Screw end fixity

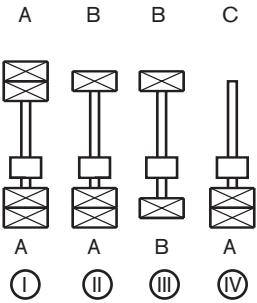

Selected:

- A = fixed bearing
- B = floating bearing
- C = without bearing

Installation conditions (enclose drawings/sketches if possible!)

Drawing enclosed

(see pages 54/55)

Type of lubrication: _____
 Operating temperature: _____ °C - _____ min/max. / _____ °C
 Exceptional operating conditions: _____

Sender
 OEM User Distributor
 Company _____
 Address _____

Name _____
 Department _____
 Telephone _____
 Fax _____
 e-mail _____

Bosch Rexroth AG
Ernst-Sachs-Straße 100
97424 Schweinfurt, Germany
Tel. +49 9721 937-0
Fax +49 9721 937-275
www.boschrexroth.com

Find your local contact person here:
www.boschrexroth.com/addresses