

Roller Rail Systems

Roller Runner Blocks, Roller Guide Rails, Accessories

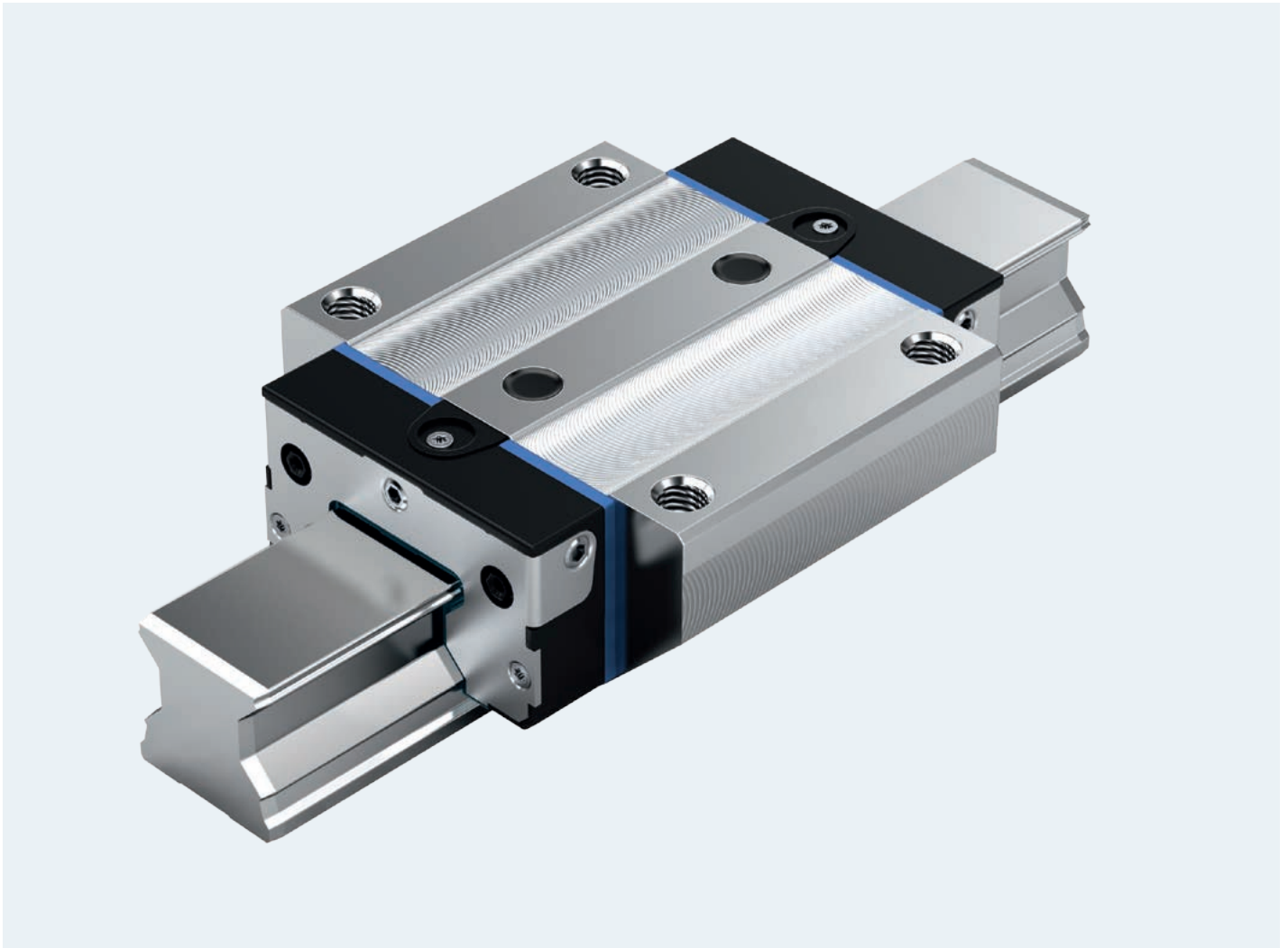
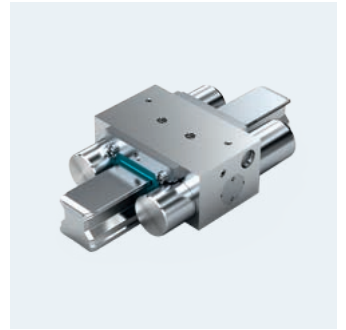
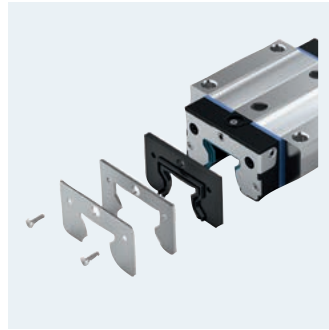
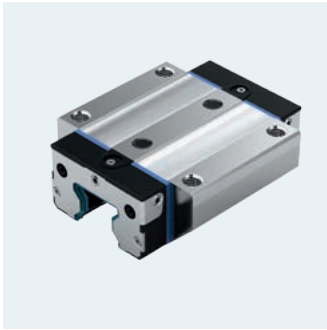

General Product Description	4	Standard Steel Roller Guide Rails	64
Product Description	5	Product Description	64
Design Types	6	Overview of Design Types and Models	64
Structural Design and Materials	7	SNS/SNO with Cover Strip and Strip Clamps R1805 .3. ./R1805 .B. ..	66
General Notes	8	SNS/SNO with Cover Strip and Protective End Caps R1805 .6. ./R1805 .D. ..	68
Intended Use	8	SNS/SNO for Cover Strip R1805 .2. 3./R1805 .A. 3.	70
Misuse	8	SNS/SNO with Plastic Mounting Hole Plugs R1805 .5. 3./R1805 .C. 3.	72
General Safety Instructions	8	SNS/SNO with Steel Mounting Hole Plugs R1806 .5. 3./R1806 .C. 3.	74
Directives and Standards	9	SNS for Mounting from Below R1807 .0. 3.	76
Selection of a Linear Guide acc. to DIN 637	10		
Product Description High Precision Version	11		
Product Overview Roller Runner Blocks with Load Capacities	18		
Product Overview Roller Guide Rails with Rail Lengths	19		
General Technical Data and Calculations	20		
Selection Criteria	28	Resist CR Roller Rail Systems	78
Rigidity of the Standard Roller Runner Blocks FNS	28	Product Description Roller Runner Blocks, Resist CR	78
Rigidity of the Standard Roller Runner Blocks FLS	30	Product Description Roller Guide Rails, Resist CR, Matte Silver Hard Chrome Plated	80
Rigidity of the Standard Roller Runner Blocks SNS/SNH	32	Product Description Roller Guide Rails, Resist CR, Black Hard Chrome Plated	82
Rigidity of the Standard Roller Runner Blocks SLS/SLH	34		
Rigidity of the Wide Roller Runner Blocks BLS	36	Wide Roller Rail Systems	84
Rigidity of the Heavy Duty Roller Runner Blocks FNS	40	Product Description	84
Rigidity of the Heavy Duty Roller Runner Block FLS	41	Wide Roller Runner Blocks BLS – Wide, Long, Standard Height	
Rigidity of the Heavy Duty Roller Runner Blocks FXS	42	Steel R1872 ... 1. / Resist CR R1872 ... 6.	86
Accuracy Classes	44	Wide Roller Guide Rails BNS with Cover Strip Steel R1875 .6. .. / Resist CR R1873 .6. ..	88
Preload	48		
RSHP Steel Roller Runner Blocks	50	Heavy-Duty Roller Rail Systems	90
Product Description	50	Product Description	90
FNS – Flanged, normal, standard height R1851 ... 2X	52	Heavy Duty Roller Runner Blocks FNS – Flange, Normal, Standard Height, Steel R1861 ... 1. / Resist CR R1861 ... 6.	92
FLS – Flanged, Long, Standard Height R1853 ... 2X	54	Heavy Duty Roller Runner Blocks FLS – Flanged, Long, Standard Height, Steel R1863 ... 1. / Resist CR R1863 ... 6.	94
SNS – Slimline, Normal, Standard Height R1822 ... 2X	56	Heavy Duty Roller Runner Blocks FXS – Flanged, Extra Long, Standard Height, Steel R1854 ... 1.	96
SLS – Slimline, Long, Standard Height R1823 ... 2X	58	Heavy Duty Roller Guide Rails SNS with Cover Strip, Steel R1835 .6. .. / Resist CR R1865 .6. ..	98
SNH – Slimline, Normal, High R1821 ... 2X	60	Heavy Duty Roller Guide Rails SNS with Steel Mounting Hole Plugs R1836 .5. ..	100
SLH – Slimline, Long, High R1824 ... 2X	62		

Accessories for RSHP Roller Runner Blocks	102	Pneumatic Clamping and Braking Units	
Overview of Accessories for Roller Runner Blocks	102	Product Description	144
Scraper Plate	103	Pneumatic Clamping and Braking Units MBPS	
FKM Seal	104	R1810 .40 31	146
FKM Seal Set	105	Pneumatic Clamping and Braking Units UBPS	
Front Lube Units	106	R1810 .40 51	148
Bellows	110	Pneumatic Clamping Units	
Lube Connections	115	Product Description	150
		Pneumatic Clamping Units MK	
Accessories for Roller Guide Rails	118	R1810 .42 60	152
Overview of Accessories for Roller Guide Rails	118	Pneumatic Clamping Units MKS	
Mounting Runner Block	119	R1810 .40 60	154
Cover Strip	120	Manual Clamping Units, Spacer Plates	
Mounting Tools for Cover Strip	122	Product Description	156
Parts for Securing the Cover Strip	123	Manual Clamping Unit HK	
Plastic Mounting Hole Plugs	124	R1619 .42 82	158
Steel Mounting Hole Plugs	125	Spacer Plate for MK, MKS, HK	159
Mounting Tool for Steel Mounting Hole Plugs	125		
Adjusting Shafts	126	Mounting	160
Wedge Profile	127	General Mounting Instructions	160
		Fastening	166
Spare Parts	128		
End Seal	128	Lubrication	174
Set of End Caps with End Seals	129	Lubrication Notes	174
Transport and Mounting Arbor	130	Lubrication of the RSHP	176
		Lubrication of the Heavy Duty Roller Rail System	186
Clamping and Braking Units	132	Maintenance	198
Hydraulic Clamping and Braking Units			
Product Description	132		
Hydraulic Clamping and Braking Units KBH	134		
FLS	134		
SLH	135		
Safety Notes on Clamping and Braking Units	136		
Hydraulic Clamping Units	138		
Product Description	138		
Hydraulic Clamping Units KWH	140		
FLS	140		
SLS	141		
SLH	142		

New Features at a Glance

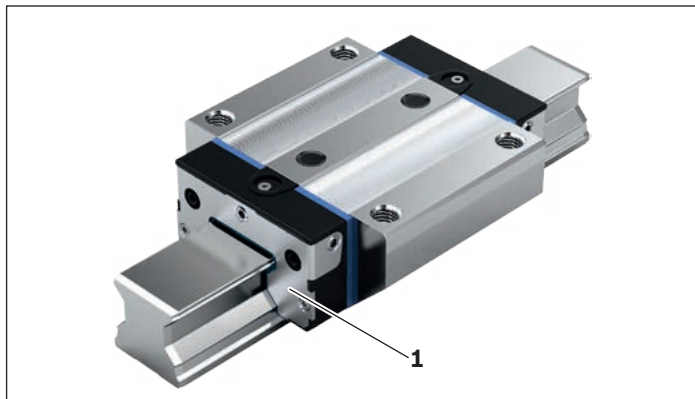

Threaded plate

- ▶ The metal threaded plate (1) for the roller runner block replaces the previous additional end seal with the same protective function and at the same time is used for the secure fastening of the lube nipple.

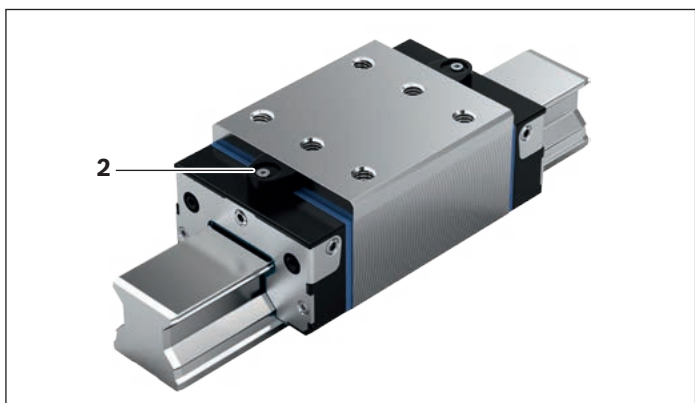

Optimized lube fitting positions

- ▶ Permit lubrication from all sides in all mounting orientations.
- ▶ Due to the integrated height compensation (2) additional lubrication adapters are no longer necessary on high roller runner blocks.

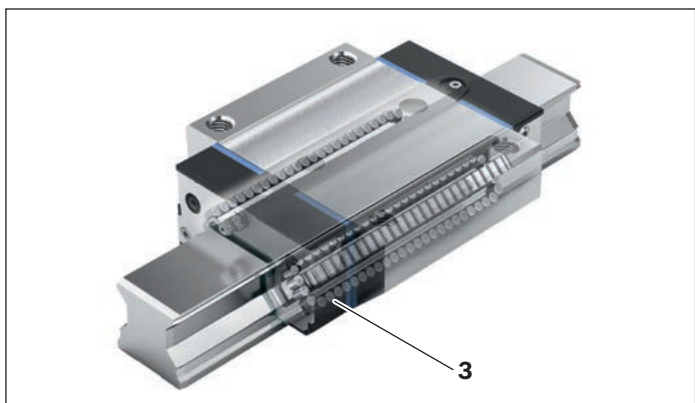

High precision technology

- ▶ Due to the optimized roller entry-zone geometry particularly in the recirculation area (3) the travel accuracy is significantly further increased.

Many possibilities with few roller runner block versions

- ▶ Due to this new functionality, special versions for unusual applications (e.g. wall mounting) are unnecessary. As a result selection is simplified.

Product Description

Rexroth Roller Rail Systems were specially developed for use in machine tools, industrial robots and general machine construction applications calling for compact, rolling-element linear motion guideways. They are available in various accuracy classes, each with extremely high load capacity and high rigidity.

Characteristic features

Standard Roller Rail Systems are suitable for all typical applications. These space-saving assemblies in many common sizes afford the same high load capacities in all four major planes of load application.

Standard roller runner blocks can also be supplied for special conditions of installation and use and for special working environments.

Wide Roller Rail Systems were developed to cater for high moment loads and highest rigidity requirements.

For heavy duty applications there is a choice of Heavy Duty Roller Rail Systems.

Further highlights

- ▶ Uniform roller guide rail profile with or without cover strip allows unrestricted interchangeability of components across all roller runner block variants
- ▶ Lube ports on all sides for maximum ease of maintenance
- ▶ Novel lube duct design minimizes lubricant consumption
- ▶ Smooth running thanks to optimized roller recirculation and guidance
- ▶ Attachments can be mounted to roller runner blocks from above or below
- ▶ Maximum rigidity under load from all directions through two additional mounting screw holes at the center of the roller runner block

Make up your own compact linear motion guideways from interchangeable standard stock elements...

Rexroth fabricates its roller guide rails and roller runner blocks with such high precision that each individual component element can be replaced by another at any time. This makes infinite combinations possible.

Each element can be individually ordered and separately stocked. Both sides of the roller guide rail can be used as reference edges.

Accessories can be simply attached to the ends of the roller runner block.

- ▶ High torque capacity
- ▶ Further optimized entry zone geometry and high number of rollers per track minimize variation in elastic deflection and provide maximum precision travel accuracy
- ▶ The roller runner block simply slides off its arbor and onto the rail
- ▶ Integrated all-around sealing as standard

Optional

- ▶ Corrosion-resistant roller runner blocks and roller guide rails Resist CR, hard chrome plated, come in accuracy class H; accuracy classes P and SP on request

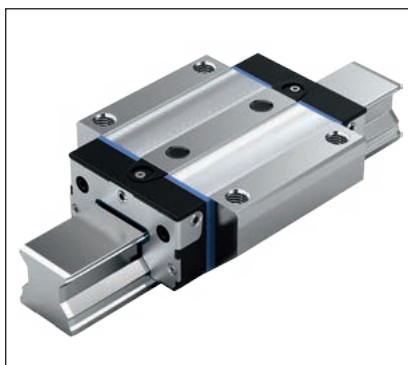

Design Types

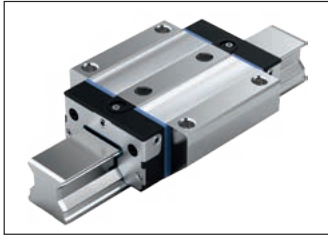

FNS – Flanged, normal, standard height

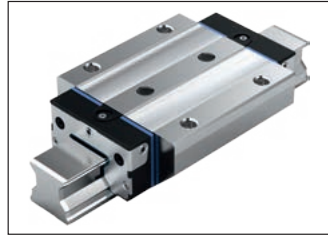

FLS – Flanged, long, standard height

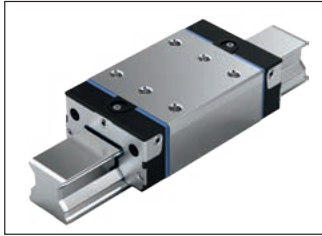

SNS – Slimline, normal, standard height

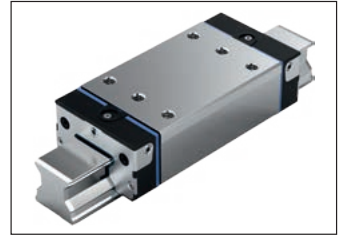

SLS – Slimline, long, standard height



SNH – Slimline, normal, high



SLH – Slimline, long, high



BLS – Wide, long, standard height



FXS – Flanged, extra long, standard height

Definition of roller runner block design types

Criterion	Description	Code (example)		
		F	N	S
Width	Flanged	F		
	Slimline		S	
	Wide (B)	B		
Length	Normal		N	
	Long		L	
	Extra-long		X	
Height	Standard height			S
	High			H

Design type with flange –

Mounting of attachments from above and below

Slimline and wide design type –

Mounting of attachments from above



Roller guide rail SNS with proven cover strip for covering mounting holes

- ▶ A single cover for all holes – saves time and money
- ▶ Stainless spring steel to EN 10088
- ▶ Easy, secure mounting
- ▶ Clip on and fasten

Definition of roller guide rail design types

Criterion	Description	Code (example)		
		S	N	S
Width	Slimline	S		
	Wide (B)	B		
Length	Normal		N	
Height	Standard height			S
	Without slot (O)			O

Structural Design and Materials

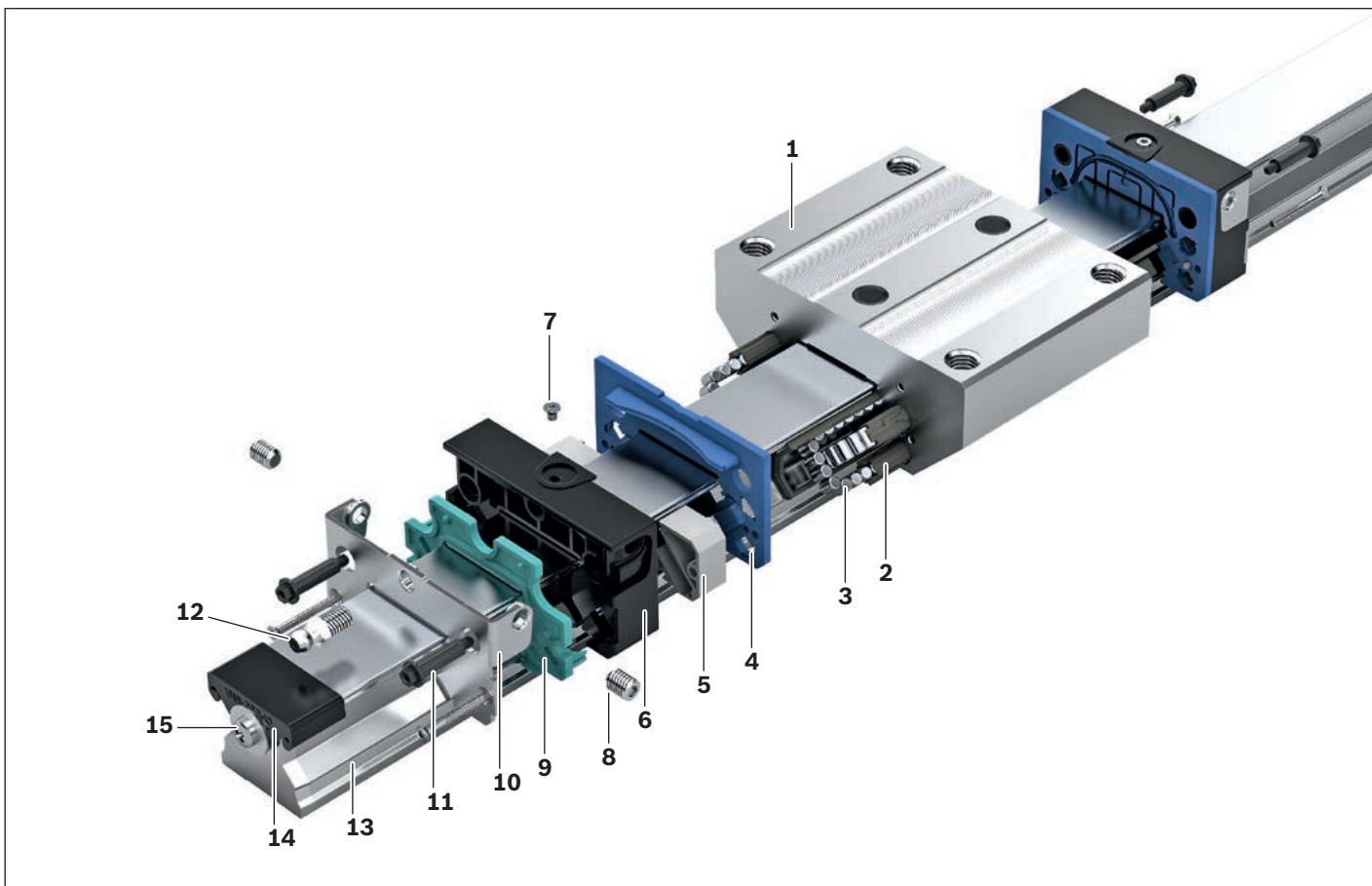

Components and their materials

Position	Component	Roller runner blocks		Roller guide rails	
		Steel	Resist CR	Steel	Resist CR
1	Roller runner block body	Heat-treated steel	Heat-treated steel, chrome-plated		
2	Return channel	Plastic	Plastic		
3	Cylindrical rollers	Antifriction bearing steel	Antifriction bearing steel		
4	Recirculation plate	Plastic	Plastic		
5	Recirculating piece	Plastic	Plastic		
6	Roller guidance	Plastic	Plastic		
7	Screw plug	Carbon steel	Carbon steel		
8	Set screw	Corrosion-resistant steel	Corrosion-resistant steel		
9	Sealing plate	Plastic	Plastic		
10	Threaded plate	Corrosion-resistant steel	Corrosion-resistant steel		
11	Hex screws	Carbon steel	Carbon steel		
12	Lube nipple	Carbon steel	Carbon steel		
13	Roller guide rail			Heat-treated steel	Heat-treated steel chrome-plated
14	Protective end cap			Plastic	Plastic
15	Screw/washer			Corrosion-resistant steel	Corrosion-resistant steel

Notes

General Notes

- Combinations of different accuracy classes

Combining roller guide rails and roller runner blocks of different accuracy classes results in different tolerances for dimensions H and A₃. See “Accuracy classes and their tolerances.”

Intended Use

- The Roller Rail Systems are linear guides capable of absorbing forces from all transverse directions and moments about all axes. The Roller Rail System is intended exclusively for guiding and positioning tasks when installed in a machine.
- The product is intended exclusively for professional use and not for private use.
- Use for the intended purpose also includes the requirement that users must have read and understood the related documentation completely, in particular the “Safety Instructions.”

Misuse

Use of the product in any other way than as described under “Intended Use” is considered to be misuse and is therefore not permitted. If unsuitable products are installed or used in safety-relevant applications, this may lead to uncontrolled operating statuses in the application which can cause personal injury and/or damage to property.

The product may only be used in safety-relevant applications if this use has been expressly specified and permitted in the product documentation.

Bosch Rexroth AG will not accept any liability for injury or damage caused by misuse of the product. The risks associated with any misuse of the product shall be borne by the user alone.

Misuse of the product includes:

- the transport of persons

General Safety Instructions

- The safety rules and regulations of the country in which the product is used must be complied with.
- All current and applicable accident prevention and environmental regulations must be adhered to.
- The product may only be used when it is in technically perfect condition.
- The technical data and environmental conditions stated in the product documentation must be complied with.
- The product must not be put into service until it has been verified that the final product (for example a machine or system) into which the product has been installed complies with the country-specific requirements, safety regulations and standards for the application.
- Rexroth Roller Rail Systems may not be used in zones with potentially explosive atmospheres as defined in the ATEX directive 94/9/EC.
- Rexroth Roller Rail Systems must never be altered or modified. The user may only perform the work described in the “Quick User Guide” or the “Mounting Instructions for Roller Rail Systems.”
- The product must never be dismantled.
- At high travel speeds a certain amount of noise is caused by the product. If necessary appropriate measures are to be taken to protect the hearing.
- Special safety requirements in specific sectors (e.g. cranes, theaters, foodstuffs) in laws, directives and standards are to be observed.
- In principle the following standard is to be observed: DIN 637, Safety regulations for dimensioning and operation of profiled rail guides with recirculating rolling elements.

Directives and Standards

Rexroth Roller Rail Systems are suitable for dynamic linear applications requiring reliability and precision. The machine tool industry and other sectors must observe a series of standards and directives. These requirements can vary significantly worldwide. It is therefore essential to understand the legislation and standards that apply in each particular region.

EN ISO 12100

This standard is entitled Safety of machinery – General principles for design, risk assessment and risk reduction. It gives a general overview and contains a guide to the major developments governing machines and their intended use.

Directive 2006/42/EC

The Machinery Directive describes the basic safety and health requirements for the design and manufacture of machinery. The manufacturer of a machine or his authorized representative has a duty to ensure that a risk assessment has been performed in order to determine the health and safety requirements which have to be fulfilled for that machine. The machine must be designed and built with the results of the risk assessment in mind.

Directive 2001/95/EC

This directive covers general safety requirements for any product placed on the market and intended for consumers, or likely to be used by consumers under reasonably foreseeable conditions, including products that are made available to consumers in the context of service provision for use by them.

Directive 1999/34/EC

This directive concerns liability for defective products and applies to industrially manufactured movables, irrespective of whether they have been incorporated into another movable or into an immovable or not.

Regulation (EC) No. 1907/2006 (REACH)

This regulation relates to restrictions on the marketing and use of certain dangerous substances and preparations. “Substances” means chemical elements and their compounds as they occur in the natural state or as produced by industry. “Preparations” means mixtures or solutions composed of two or more substances.

Selection of a Linear Guide acc. to DIN 637

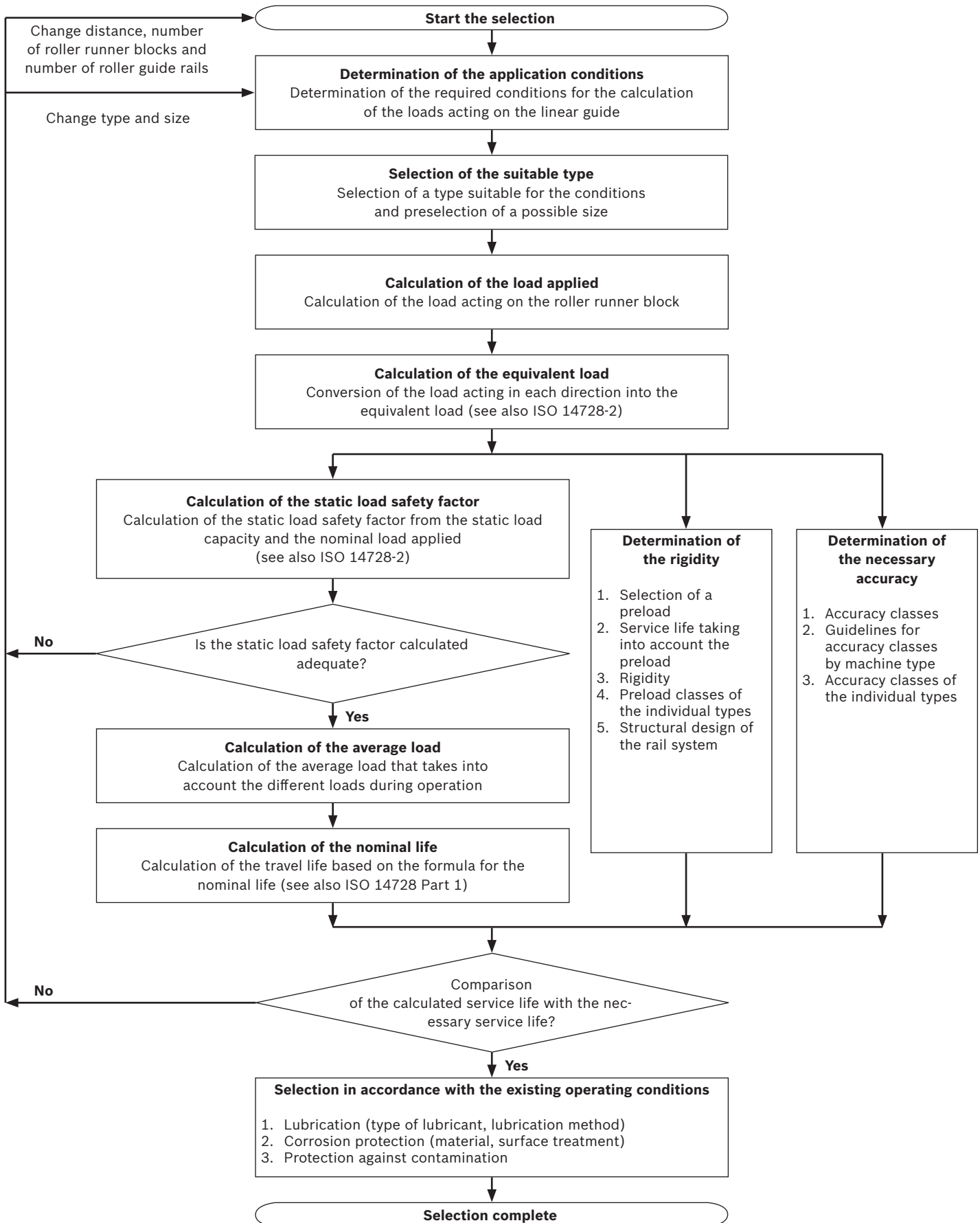

Product Description High Precision Version

Design styles of the high precision roller runner blocks

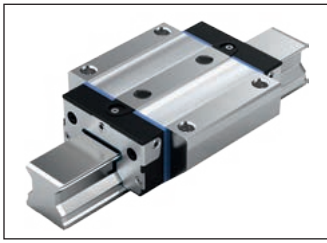

FNS – Flanged, normal, standard height

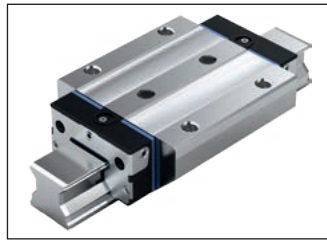

FLS – Flanged, long, standard height

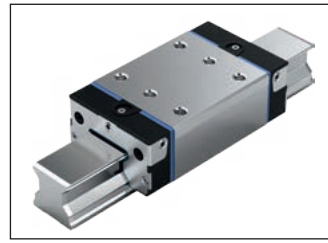

SNS – Slimline, normal, standard height

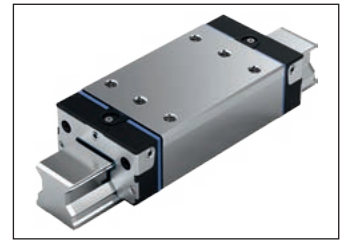

SLS – Slimline, long, standard height

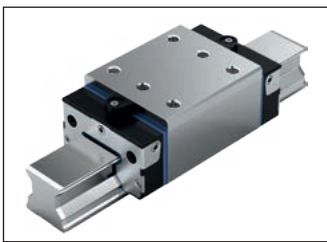

SNH – Slimline, normal, high



SLH – Slimline, long, high

Application examples

Rexroth high precision roller runner blocks are especially suited for the following applications:

Grinding



Grinding of fitting bores

Internal cylindrical grinding

Milling



Mold insert milling

Hard milling

Turning

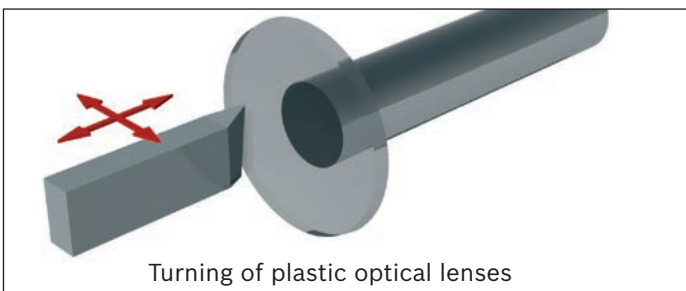

Turning of plastic optical lenses

High precision turning

These are just a few examples of the many possible applications. Simply ask us. We'll find the right solution for your needs.

Product Description High Precision Version

Highlights

- ▶ Increased travel accuracy
- ▶ Significantly reduced frictional drag variations and low frictional drag, especially under an applied external load
- ▶ Highest precision
- ▶ Superior quality
- ▶ Extremely low impact on surrounding environment due to minimal oil preservation
- ▶ Patented entry zone design enhances travel accuracy

Comparison

Conventional roller runner blocks

If the roller runner block has a conventional entry zone, this can only be designed for a specific load point.

Entry zone geometry for conventional roller runner blocks

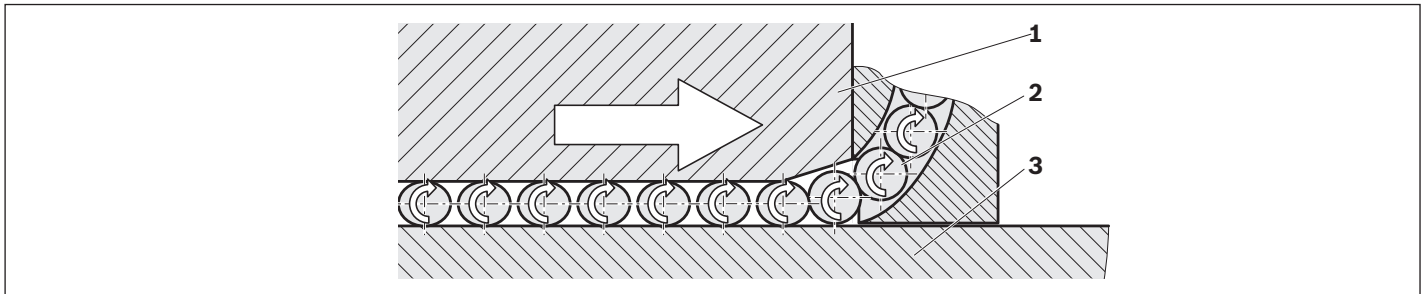

1 Roller runner block 2 Rollers 3 Roller guide rail

Roller entry

- ▶ The rollers are guided to the beginning of the entry zone by the roller recirculation track.
- ▶ When the distance between the roller runner block (1) and the roller guide rail (3) becomes smaller than the roller diameter, the roller (2) is subjected to loading (preload) in a series of pulses.
- ▶ The preload increases in the entry zone and reaches a maximum in the load-bearing zone. The roller transmits the force from the roller runner block to the roller guide rail.
- ▶ The kinematic and geometric conditions cause spaces to develop between the rollers.

Entry zone

Conventional roller runner blocks have a fixed entry zone. The depth of the entry zone must be designed to withstand high loading, since smooth roller entry must be assured even under very high loads.

- ▶ On the one hand, there should be as many load-bearing rollers as possible at any one time in the roller runner block to ensure optimal load capacity of the linear bearing.
 - ⇒ Shortest possible entry zone
- ▶ On the other hand, the increase in loading of the rollers upon entry should be as slow and smooth as possible, in order to maximize the geometrical travel accuracy.
 - ⇒ Shallowest (longest) possible entry zone

These are conflicting aims (short versus long entry zone).

High precision roller runner blocks

New entry zone geometry for high precision roller runner blocks

High precision roller runner blocks have an innovative entry zone. The rollers enter the load-bearing zone very smoothly, i.e. without any load pulsation.

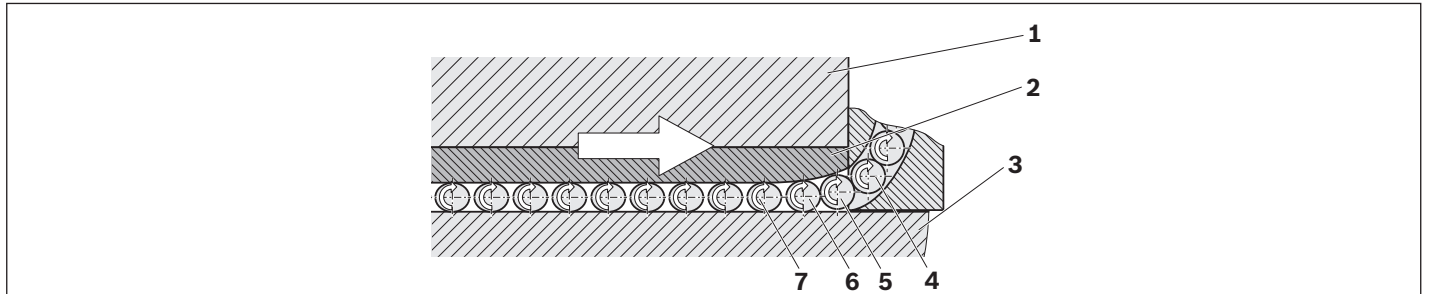

- | | |
|------------------------------|----------------------------|
| 1 Roller runner block | 3 Roller guide rail |
| 2 Steel segment | 4 - 7 Rollers |

Roller entry

- ▶ The rollers (4) are guided to the beginning of the entry zone by the roller recirculation track.
- ▶ The roller (5) can enter.
- ▶ As the distance between the steel segment and the roller guide rail becomes smaller than the roller diameter, the roller is gradually and uniformly subjected to loading (preload).
- ▶ The preload is thus smoothly increased until the rollers (7) have reached their maximum preload.

Innovative solution from Rexroth:

The optimized entry zone

The functionality of the entry zone is key. The steel segments are manufactured with such precision that the load on them increases with the convex curvature. This results in especially smooth roller entry behavior.

The rollers are no longer guided into the load-bearing zone in pulses by an inclined entry channel but by a very smooth flexing curve, which ideally transitions tangentially into the load-bearing zone.

The extremely smooth roller entry behavior and the optimized adjustment of the entry zone in response to the actual load are a great advantage of these high precision roller runner blocks.

Characteristic features

- 1** Highest travel accuracy
- 2** Minimal frictional drag variation
- 3** The conflicting aims are resolved

Product Description High Precision Version

Frictional drag variations

Definition

The total frictional drag of a roller runner block is composed of the following components:

- 1 Roller friction
- 2 Friction of the seals
- 3 Friction in the roller recirculation elements and recirculation tracks

Variations in frictional drag can be especially troublesome in certain operating environments.

These variations are mainly due to the following fact:

The rollers have to transition from the load-free zone to the load-bearing zone. Through its innovative design, the optimized roller entry zone minimizes the variations, which also permits better control of the linear drive.

Conventional roller runner block

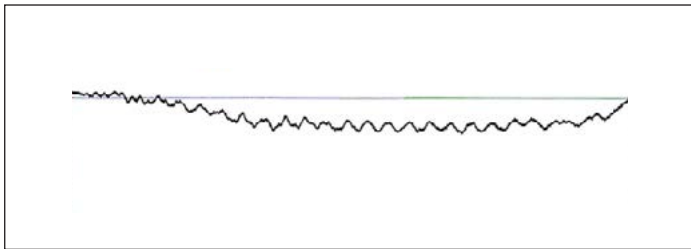

High precision roller runner block

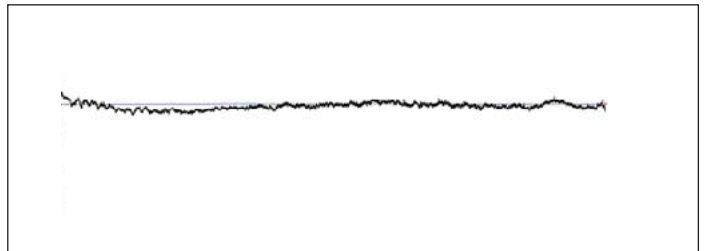

Travel accuracy

Definition

Ideally, the roller runner block should move in a straight line along the roller guide rail in the direction of the X-axis. In practice, however, deviations occur in all six degrees of freedom. Travel accuracy is the term used to describe the closeness of the movement to the ideal straight line.

The six different degrees of freedom

- 1 Vertical offset (linear deviation in the Z-direction)
- 2 Yawing (rotation about the Z-axis)
- 3 Lateral offset (linear deviation in the Y direction)
- 4 Pitching (rotation about the Y-axis)
- 5 Translation (linear motion in the X-direction)
- 6 Rolling (rotation about the X-axis)

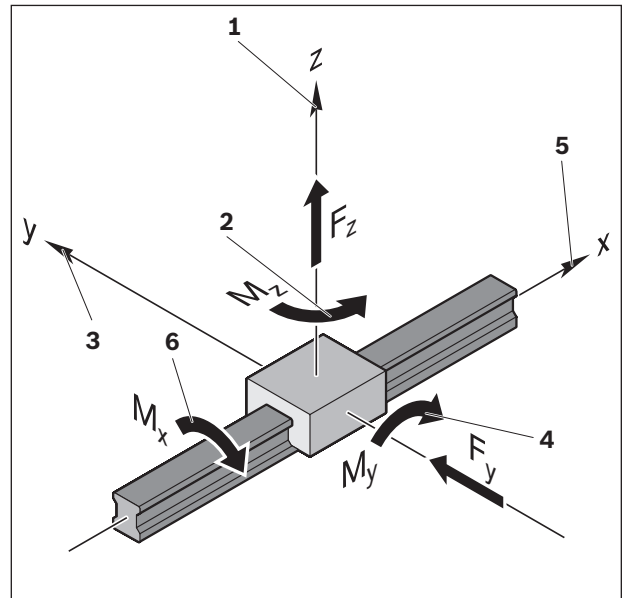

Causes of travel inaccuracy

Travel accuracy is influenced by the following parameters:

1. The finish of the mounting base to which the roller guide rail is fastened.
2. Parallelism errors between the contact surfaces of the roller guide rail and the running tracks.
3. Elastic deformations of the roller guide rail under the mounting screws.
4. Variations in accuracy as rollers enter and exit the load-bearing zone.

Optimization potential

Re 1.: Machine the mounting base for the roller guide rail with the greatest possible precision (beyond the control of Bosch Rexroth).

Re 2.: The deviation can be influenced by choosing an appropriate accuracy class for the roller guide rail.

Re 3.: Reduce the tightening torque. The tightening torque for the fastening screws has a proportional effect. Reducing the torque will lessen the compression of the rail material.

⇒ Reduced geometric variation in travel characteristics

⚠ NOTE: This may result in a decrease in the transmittable forces and moments.

Re 4.: The patented, optimized entry zone design of the Rexroth high precision roller runner blocks minimizes these accuracy deviations.

Potential further improvements:

- ▶ Use of long roller runner blocks
- ▶ Installation of additional roller runner blocks per roller guide rail

Product Description High Precision Version

The deviations measured are due to the following phenomenon

A roller circuit contains a number n of load-bearing rollers. When the roller runner block is moved in the direction of travel, a new roller engages in the entry zone. Now there are $n+1$ load-bearing rollers. This creates an imbalance between the four rows of load-bearing rollers. Because the rollers enter the load-bearing zones randomly, the roller runner block begins to rotate in an attempt to restore the balance. As the roller runner block moves further on, a roller leaves the load-bearing part of the circuit through the run-out zone. This again creates an imbalance between the four load-bearing roller circuits, which the roller runner block again attempts to correct by rotating.

This effect is clearly shown in the diagram at right.

As demonstrated in practical applications, the short-wave inaccuracies have a period equivalent to approximately twice the roller diameter.

The remaining long-wave deviation is the result of the causes 1, 2 and 3 described earlier (mounting base finish, parallelism error, and elastic deformation of the roller guide rail under the fastening screws).

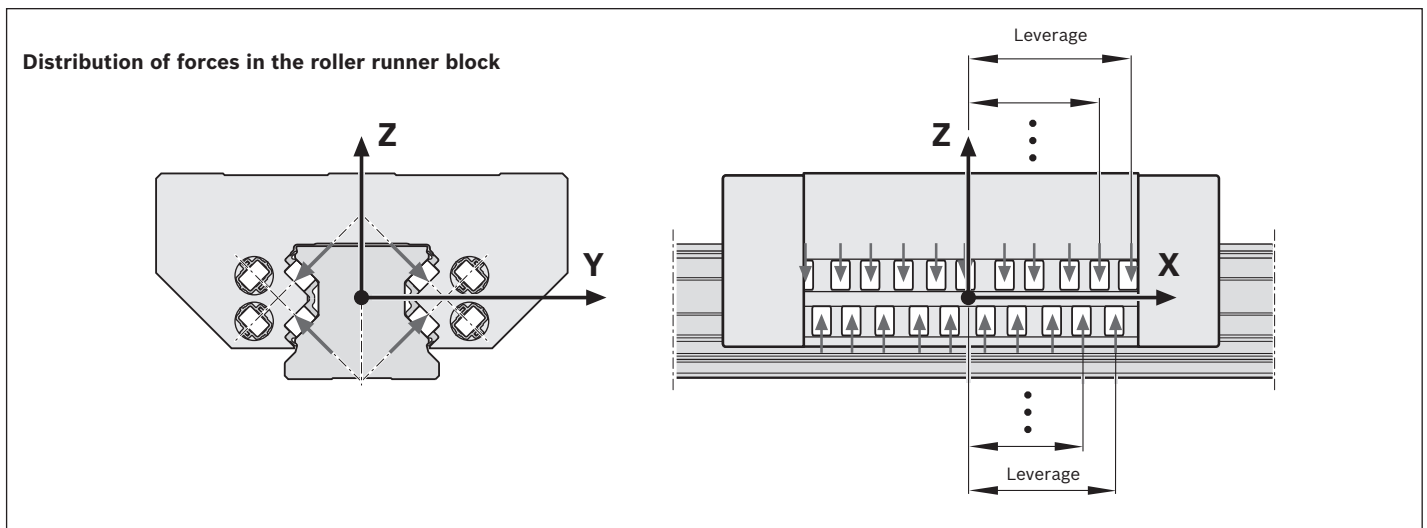





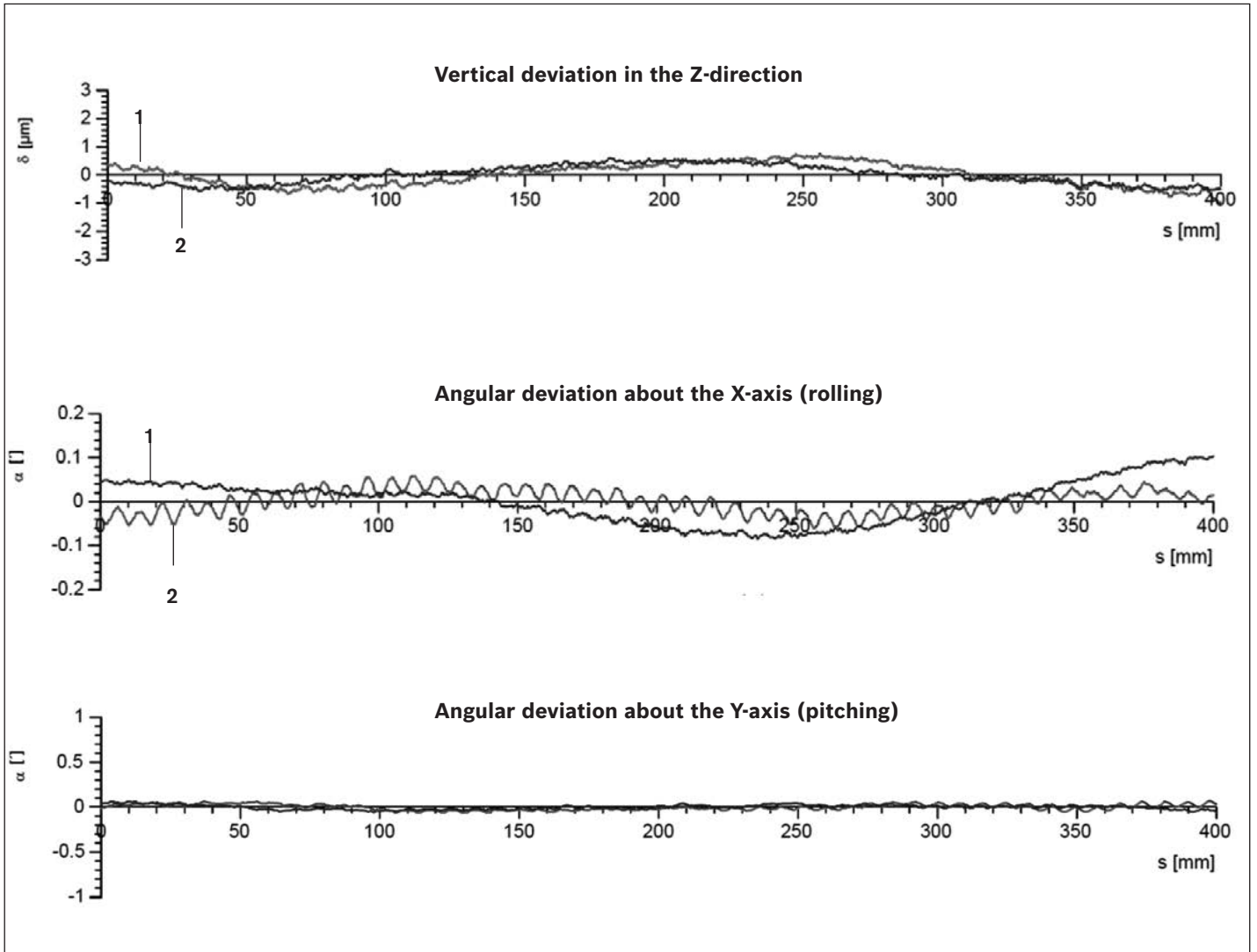





Direct comparison of the travel accuracy of two roller runner blocks

The diagrams clearly show that the short-wave inaccuracies can be very significantly reduced by the new, optimized design of the entry zone.





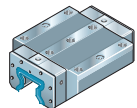
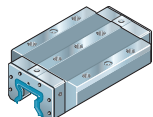



- 1) High precision version
- 2) Conventional version

Product Overview Roller Runner Blocks with Load Capacities

Roller runner blocks			Page	Size									
				25	30	35	45	55	65	100	125		
			Load capacities ¹⁾ (N)										
													
Standard steel roller runner blocks		FNS R1851 ... 2X	52	C	30300	46300	61000	106600	140400	237200			
		R1851 ... 7X Resist CR	79	C₀	59500	92100	119400	209400	284700	456300			
		FLS R1853 ... 2X	54	C	36800	58400	74900	132300	174000	295900			
		R1853 ... 7X Resist CR	79	C₀	76400	123900	155400	276400	374900	606300			
		SNS R1822 ... 2X	56	C	30300	46300	61000	106600	140400	237200			
		R1822 ... 7X Resist CR	79	C₀	59500	92100	119400	209400	284700	456300			
		SLS R1823 ... 2X	58	C	36800	58400	74900	132300	174000	295900			
		R1823 ... 7X Resist CR	79	C₀	76400	123900	155400	276400	374900	606300			
		SNH R1821 ... 2X	60	C	30300	46300	61000	106600	140400				
		R1821 ... 7X Resist CR	79	C₀	59500	92100	119400	209400	284700				
		SLH R1824 ... 2X	62	C	36800	58400	74900	132300	174000				
		R1824 ... 7X Resist CR	79	C₀	76400	123900	155400	276400	374900				
				Size					55/85	65/100			
Wide steel roller runner blocks		BLS R1872 ... 10	86	C				–	165000	265500			
		R1872 ... 60 Resist CR	86	C₀					–	345300	525600		
				Size					65	100	125		
Heavy duty steel roller runner blocks		FNS R1861 ... 10	92	C				–			461000	811700	
		R1861 ... 60 Resist CR	92	C₀					–			757200	1324000
		FLS R1863 ... 10	94	C					–			632000	1218000
		R1863 ... 60 Resist CR	94	C₀					–			1020000	1941900
		FXS R1854 ... 10	96	C					–		366800	–	–
				C₀					–		792800	–	–

1) Determination of the dynamic load capacities and moments is based on a travel life of 100,000 m per ISO 14728 Part 1. Often only 50,000 m are actually stipulated. If this is the case, for comparison purposes: Multiply values C, M_t and M_L from the table by 1.23.

Product Overview Roller Guide Rails with Rail Lengths

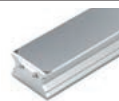
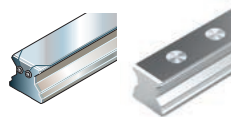
Roller guide rails				Page	Size					
					25	30	35	45	55	65
				Rail length (mm)						
Standard roller guide rails made of steel¹⁾ and Resist CR²⁾ for mounting from above	 with cover strip and strip clamps	SNS	R1805 .3. ...	66	3986	3996	3996	3986	3956	3971
			R1845 Resist CR	81/83						
	 with cover strip and protective end caps	SNS	R1805 .6. ...	68						
			R1845 Resist CR	81/83						
	 for cover strip	SNS	R1805 .2. ...	70						
			R1845 Resist CR	81/83						
	 with plastic mounting hole plugs	SNS	R1805 .5. ...	72						
			R1845 Resist CR	81/83						
	 with steel mounting hole plugs	SNS	R1806 .5. ...	74						
			R1846 Resist CR	81/83						
for mounting from below		SNS	R1807 .0. ...	76						
			R1847 Resist CR	81/83						
							55/85	65/100		
Wide steel roller guide rails	 with cover strip	BNS	R1875 .6. ...	88	3956				3971	
			R1873 .6. ... Resist CR	88						
							100	125		
Heavy duty steel roller guide rails	 with cover strip/ with steel mounting hole plugs	SNS	R1835 .6. ...	98	3986				2760	
			R1836 .5. ...	100						
			R1865 .6. ... Resist CR	98						

1) Sizes 30 and 35: one-piece length up to 5996 mm also available

Size 45: one-piece length up to 5981 mm also available

Size 55: one-piece length up to 5936 mm also available

Size 65: one-piece length up to 5921 mm also available

2) Resist CR: Steel roller guide rails with corrosion-resistant coating, matte silver hard chrome plated

General Technical Data and Calculations

General notes

The general technical data and calculations apply to all Roller Rail Systems, i.e., to all roller runner blocks and roller guide rails. Specific technical data relating to the individual roller runner blocks and roller guide rails is given separately.

Preload classes

To cater for the widest possible range of applications, Rexroth roller runner blocks (RB) are provided in different preload classes.

The following preload classes are available as standard:

- ▶ RB with preload class C2
- ▶ RB with preload class C3

Special version on request:

- ▶ RB with preload class C1, C4, C5

So as not to reduce the service life, the preload should not exceed 1/3 of the load on bearing F.

In general, the rigidity of the roller runner block rises with increasing preload.

Guide systems with parallel rails

In addition to the preload class, the permissible parallelism offset of the rails must also be taken into account (see "Selection of Accuracy Classes").

Speed

$$v_{\max} = 4^{1)} \text{ m/s}$$

- 1)** Sizes:
55/85, 65/100, 65 FXS: 3 m/s
100 and 125: 2 m/s

Acceleration

$$a_{\max} = 150 \text{ m/s}^2$$

Requirement:
The Roller Rail System must always be preloaded, even when operated under load!

Operating temperature range

$$-10 \text{ }^{\circ}\text{C} \dots 80 \text{ }^{\circ}\text{C}$$

Brief peaks up to 100 °C are permitted.
For even lower sub-zero temperatures, please consult us.

Friction

The table lists reference values for the frictional force in a sealed and lubricated complete roller runner block.

When the roller runner block starts to move, the frictional force can be 1.5 to 2 times the given value, depending on the length of time it has been at a standstill, as well as the type, quantity and condition of the lubricant, and the amount of dirt that has accumulated on the roller guide rail.

This applies to all roller runner blocks in all preload classes. The friction coefficient μ is approx. 0.0004 to 0.001 (excluding seal friction).

Size	Friction force F_R (N)
25	30
30	40
35	40
45	60
55	70
65	90
55/85	70
65/100	90
100	400 ¹⁾
125	600 ¹⁾

1) Directly after lubrication, the frictional drag will be approx. 50% higher.

Seals

The purpose of seals is to prevent dirt, chips, etc. from entering the roller runner block and thus shortening its service life.

It also prevents the lubricant from being dragged out.

Standard

Seals are fitted to Rexroth roller runner blocks as standard. They provide equal sealing performance on roller guide rails with and without cover strip.

FKM seals

FKM seals are optional accessories to be fitted by the customer.

They are for use in environments heavily soiled with fine dirt or metal particles.

- ▶ Use in applications involving the use of coolants or cutting fluids in addition to the presence of dirt and metal particles.
- ▶ Replaceable.

Scraper plates

Scraper plates are optional accessories to be fitted by the customer.

- ▶ For use in environments with hot metal chips or welding spatter.

General Technical Data and Calculations

Forces and load moments

In Rexroth Roller Rail Systems the running tracks are arranged at a compression angle of 45° . This results in the same high load capacity of the entire system in all four major planes of load application. The roller runner blocks can be subjected to forces and to load moments.

Forces in the four major planes of load application

- ▶ Pull F_z (positive z-direction)
- ▶ Push $-F_z$ (negative z-direction)
- ▶ Side load F_y (positive y-direction)
- ▶ Side load $-F_y$ (negative y-direction)

Moments

- ▶ Moment M_x (about the x-axis)
- ▶ Moment M_y (about the y-axis)
- ▶ Moment M_z (about the z-axis)

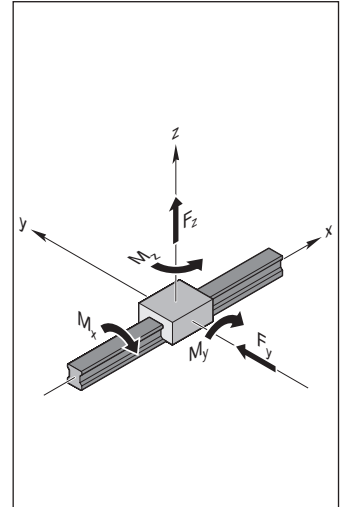

Definition of load capacities

Dynamic load capacity C

The radial loading of constant magnitude and direction which a linear rolling bearing can theoretically endure for a nominal life of 10^5 meters distance traveled (as per ISO 14728 Part 1).

Note: The dynamic load capacities given in the tables are above the ISO values. They have been proven in tests.

Static load capacity C_0

Static load in the load direction that corresponds to a calculated load in the center of the contact point with the greatest load between the rolling element and track zone (roller guide rail) of 4000 MPa.

Note: With this load on the contact point, a permanent overall deformation of the rolling element and track zone occurs, corresponding to around 0.0001 times the roller body diameter (as per ISO 14728 Part 1).

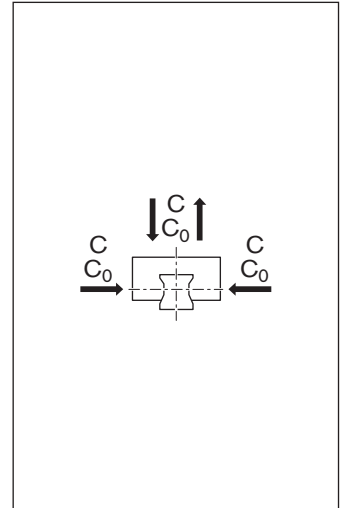

Definition of moment load capacities

Dynamic torsional moment load capacity M_t

Comparative dynamic moment about the longitudinal axis x which causes a load equivalent to the dynamic load capacity C.

Static torsional moment load capacity M_{t0}

Comparative static moment about the longitudinal axis x which causes a load equivalent to the static load capacity C_0 .

Dynamic longitudinal moment load capacity M_L

Comparative dynamic moment about the transverse axis y or the vertical axis z which causes a load equivalent to the dynamic load capacity C.

Static longitudinal moment load capacity M_{L0}

Comparative static moment about the transverse axis y or the vertical axis z which causes a load equivalent to the dynamic load capacity C_0 .

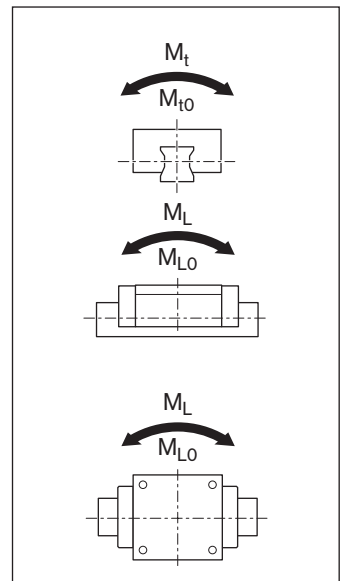

Definition and calculation of the nominal life

The calculated service life which an individual linear rolling bearing, or a group of apparently identical rolling element bearings operating under the same conditions, can attain with a 90% probability, with contemporary, commonly used materials and manufacturing quality under conventional operating conditions (as per ISO 14728 Part 1) and optimal installation conditions.

Nominal life in meters

$$(1) \quad L_{10} = \left(\frac{C}{F_m} \right)^{10/3} \cdot 10^5 \text{ m}$$

Service life in operating hours at constant stroke length and stroke frequency

$$(2) \quad L_{h10} = \frac{L_{10}}{2 \cdot s \cdot n \cdot 60} \text{ h}$$

If the stroke length s and the stroke frequency n are constant throughout the service life, the service life in operating hours can be calculated using formula (2).

Nominal life at variable speed

$$(3) \quad L_{h10} = \frac{L_{10}}{60 \cdot v_m}$$

Alternatively, the service life in operating hours at average speed v_m can be calculated using formula (3). When the speed is varied in steps, this average speed v_m is calculated using the discrete time steps q_{tn} of the individual load levels (4).

$$(4) \quad v_m = \frac{|v_1| \cdot q_{t1} + |v_2| \cdot q_{t2} + \dots + |v_n| \cdot q_{tn}}{100 \%}$$

Modified life expectancy

$$L_{na} = a_1 \cdot \left(\frac{C}{F_m} \right)^{10/3} \cdot 10^5 \text{ m}$$

$$L_{ha} = \frac{L_{na}}{2 \cdot s \cdot n \cdot 60} \text{ h}$$

If 90% probability is not sufficient, the nominal life values must be reduced by the factor a_1 as given in the table below.

Probability (%)	L_{na}	Factor a_1
90	L_{10a}	1.00
95	L_{5a}	0.64
96	L_{4a}	0.55
97	L_{3a}	0.47
98	L_{2a}	0.37
99	L_{1a}	0.25

Notes

ISO 14728 Part 1 limits the applicability of formula (1) to equivalent dynamic loads $F_m < 0.5 C$. However, our tests have demonstrated that – under ideal operating conditions – this nominal life formula can be applied up to loads of $F_m = C$. For stroke lengths less than $2 \cdot$ roller runner block length B_1 (see dimension tables), a reduction in load capacity may have to be taken into account. Please consult us.

General Technical Data and Calculations

Load on bearings for calculation of nominal life

Combined equivalent load on bearing

With formula (5) all of the partial loads in a particular load case can be factored in to calculate the combined equivalent load on the bearing.

Notes

The calculation of the moment loads as shown in formula (5) applies only for applications with one single roller guide rail and one roller runner block. The formula is simpler for other combinations.

The forces and load moments shown in the coordinate system can also act in the opposite direction. An external load acting at an angle on the roller runner block is to be broken down into its F_y and F_z components, and these values are then to be used in formula (5). The structure of the roller runner block permits this simplified calculation.

$$(5) \quad F_{\text{comb}} = |F_y| + |F_z| + C \cdot \frac{|M_x|}{M_t} + C \cdot \frac{|M_y|}{M_L} + C \cdot \frac{|M_z|}{M_L}$$

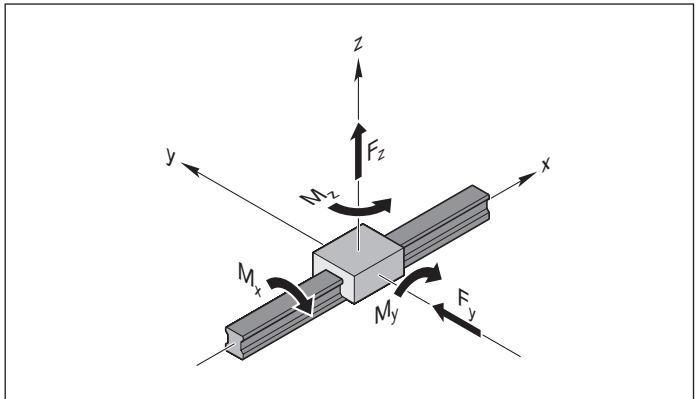

Allowance for internal preload force F_{pr}

To increase the rigidity and accuracy of the guide system preloaded roller runner blocks should be used (see also “Selection of the preload class”).

When roller runner blocks in preload classes C2 and C3 are used, it may be necessary to take the internal preload force into account since the two rows of rollers a and b are designed to be oversized and are therefore preloaded against each other with an internal preload force F_{pr} which causes them to deform by the amount δ_{pr} (see chart).

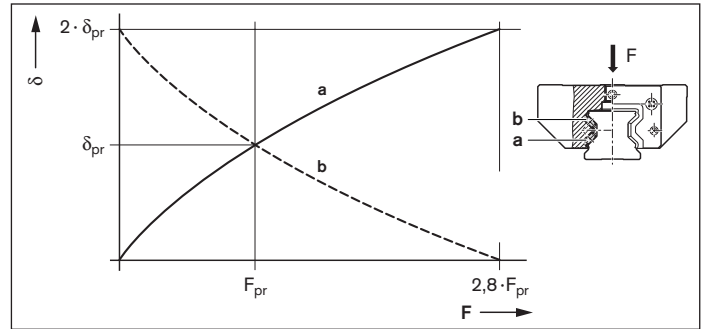

- a = loaded (lower) row of rollers
- b = non-loaded (upper) row of rollers
- δ = deformation of rollers at F
- δ_{pr} = deformation of rollers at F_{pr}
- F = load on the roller runner block
- F_{pr} = internal preload force

Effective equivalent load on bearing

When an external load reaches 2.8 times the internal preload force F_{pr} , one row of rollers becomes preload-free.

Note

For highly dynamic load cases, the combined equivalent load on the bearings should be $F_{comb} < 2.8 \cdot F_{pr}$ in order to avoid damage to the rolling bearings due to slip.

$$(6) \quad F_{eff} = F_{comb}$$

Case 1

$F_{comb} > 2.8 \cdot F_{pr}$
Here the internal preload force F_{pr} has no effect on the service life.

$$(7) \quad F_{eff} = \left(\frac{F_{comb}}{2.8 \cdot F_{pr}} + 1 \right)^{3/2} \cdot F_{pr}$$

Case 2

$F_{comb} \leq 2.8 \cdot F_{pr}$
The preload force F_{pr} is factored into the calculation of the effective equivalent load on bearing.

General Technical Data and Calculations

Equivalent dynamic load on bearing

For varying load levels, calculate the equivalent dynamic load on the bearings using formula (8).

$$(8) \quad F_m = \sqrt[10]{(F_{\text{eff } 1})^{\frac{10}{3}} \cdot \frac{q_{s1}}{100\%} + (F_{\text{eff } 2})^{\frac{10}{3}} \cdot \frac{q_{s2}}{100\%} + \dots + (F_{\text{eff } n})^{\frac{10}{3}} \cdot \frac{q_{sn}}{100\%}}$$

Equivalent static load on bearing

For combined static external loads – vertical and horizontal – in conjunction with a static torsional or longitudinal moment load, calculate the equivalent static bearing on the load $F_{0 \text{ comb}}$ using formula (9).

$$(9) \quad F_{0 \text{ comb}} = |F_{0y}| + |F_{0z}| + C_0 \cdot \frac{|M_{0x}|}{M_{t0}} + C_0 \cdot \frac{|M_{0y}|}{M_{L0}} + C_0 \cdot \frac{|M_{0z}|}{M_{L0}}$$

Notes

The equivalent static load on the bearing $F_{0 \text{ comb}}$ must not exceed the static load capacity C_0 . Formula (9) applies only when using a single roller guide rail.

An external load acting at an angle on the roller runner block is to be broken down into its F_{0y} and F_{0z} components, and these values are then to be used in formula (9).

Definitions and calculation for dynamic and static load ratios

The ratio between the load capacity of the roller runner block and the load applied to it can be used to pre-select the type of linear guide. The dynamic load ratio C/F_{max} and the static load ratio $C_0/F_{0 \text{ max}}$ should be chosen as appropriate for the application. This permits calculation of the required load capacity and selection of the guide rail size and roller runner block design style using the load capacity tables.

Recommended values for load ratios

The table below contains recommendations for load ratios.

The values are offered merely as a rough guide reflecting typical customer requirements (e.g. service life, accuracy, rigidity) by sector and application.

Case 1: Static load $F_{0 \text{ max}} > F_{\text{max}}$:

Case 2: Static load $F_{0 \text{ max}} < F_{\text{max}}$:

$$\text{Dynamic load ratio} = \frac{C}{F_{\text{max}}}$$

$$\text{Static load ratio} = \frac{C_0}{F_{0 \text{ max}}}$$

$$\text{Static load ratio} = \frac{C_0}{F_{\text{max}}}$$

Machine type/sector	Application example	C/F _{max}	C ₀ /F _{0max}
Machine tools	General	6 ... 9	> 4
	Turning	6 ... 7	> 4
	Milling	6 ... 7	> 4
	Grinding	9 ... 10	> 4
	Engraving	5	> 3
Rubber and plastics processing machinery	Injection molding	8	> 2
Woodworking and wood processing machines	Sawing, milling	5	> 3
Assembly /handling technology and industrial robots	Handling	5	> 3
Oil hydraulics and pneumatics	Raising/lowering	6	> 4

Static load safety factor S_0

Any design with rolling contact must be verified in relation to the static load safety factor. The static load safety factor for a linear guide is given by the following equation:

$$(10) \quad S_0 = \frac{C_0}{F_{0 \max}}$$

$F_{0 \max}$ represents the maximum load amplitude that can act on the linear guide. Here it is irrelevant whether the load only acts for a short time. It can represent a peak amplitude in a dynamic load spectrum. The data in the table apply to the design.

Conditions of use	Static load safety factor S_0
Overhead hanging arrangement und applications with high hazard potential	≥ 20
High dynamic stress at standstill, contamination.	8 - 12
Normal design of machines and plants, if all load parameters or connection accuracies are not known in full.	5 - 8
All load data are known in full. Shock-free movement is ensured.	3 - 5
If there are hazards for the health and safety of personnel, point 5.1.3 from DIN 637 is to be observed.	

Key to formulas

Symbols used in formulas	Unit	Description
a_1	–	Probability factor
C	N	Dynamic load capacity
C_0	N	Static load capacity (rating)
F_{\max}	N	Maximum dynamic load
$F_{0 \max}$	N	Maximum static load
F_{comb}	N	Combined equivalent load on bearing
$F_{0 \text{ comb}}$	N	Static equivalent load on bearing
F_{eff}	N	Effective equivalent load on bearing
$F_{\text{eff } 1 \dots n}$	N	Uniform effective single loads
F_m	N	Equivalent dynamic load on bearing
F_{pr}	N	Preload force
F_y	N	External load due to a resulting force in the y-direction
F_{0y}	N	External load due to a static force in the y-direction
F_z	N	External load due to a resulting force in the z-direction
F_{0z}	N	External load due to a static force in the z-direction
M_t	Nm	Dynamic torsional moment load capacity ¹⁾
M_{t0}	Nm	Static torsional moment load capacity ¹⁾
M_L	Nm	Dynamic longitudinal moment load capacity ¹⁾
M_{L0}	Nm	Static longitudinal moment load capacity ¹⁾

Symbols used in formulas	Unit	Description
M_x	Nm	Load due to a resulting moment load about the x-axis
M_{0x}	Nm	Load due to a static moment load about the x-axis
M_y	Nm	Load due to a resulting moment load about the y-axis
M_{0y}	Nm	Load due to a static moment load about the y-axis
M_z	Nm	Load due to a resulting moment load about the z-axis
M_{0z}	Nm	Load due to a static moment load about the z-axis
L_{10}	m	Nominal life (travel)
$L_{h 10}$	h	Nominal life (time)
L_{na}	m	Modified life expectancy (travel)
L_{ha}	h	Modified life expectancy (time)
n	min^{-1}	Stroke repetition rate (full cycles)
s	m	Stroke length
S_0	–	Static load safety factor
v_m	m/min	Average linear speed
$v_1 \dots v_n$	m/min	Travel speed in phases 1 ... n
$q_{t1} \dots q_{tn}$	%	Discrete time steps for $v_1 \dots v_n$ in phases 1 ... n

1) For values, see tables

Rigidity of the Standard Roller Runner Blocks FNS

Rigidity of the roller rail system at preload C2

Standard roller runner block FNS R1851

Roller runner block mounted using 6 screws:

- ▶ 4 outer screws of strength class 12.9
- ▶ 2 centerline screws of strength class 8.8

Down load

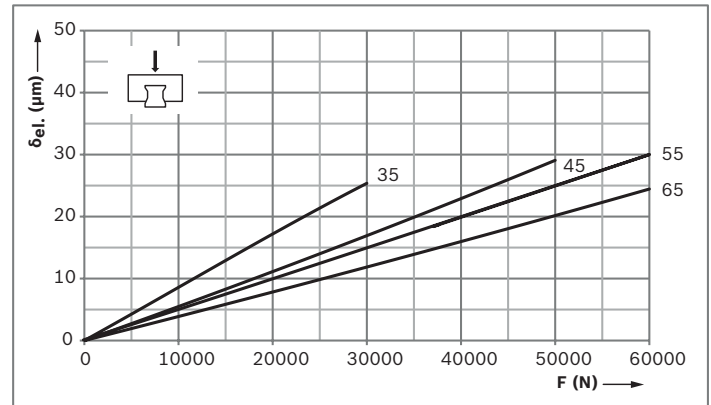

Lift-off load

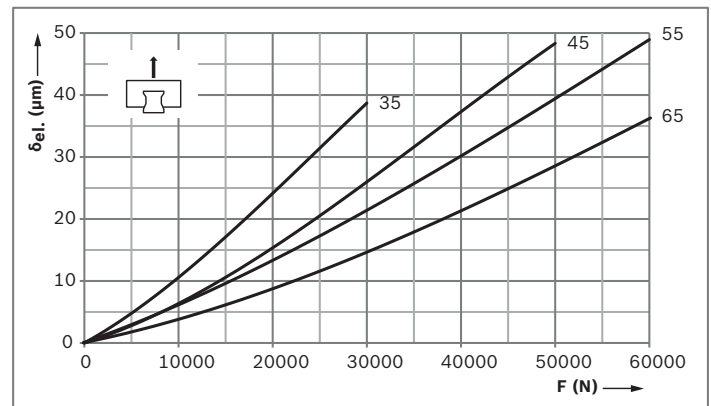

Side load

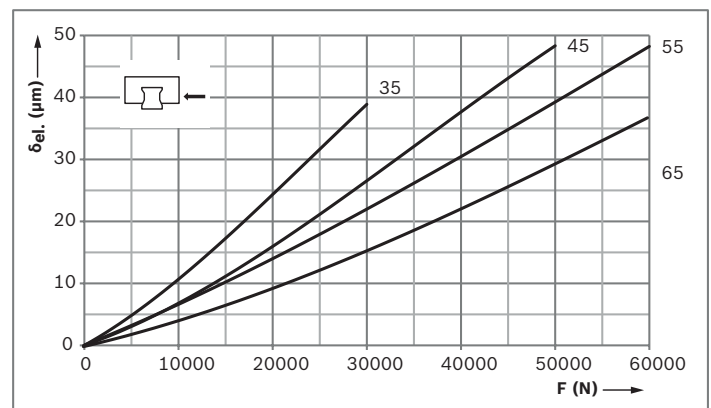

Preload class

C2 = preload (as per table for preload force F_{pr})

Key to graphs

$\delta_{el.}$ = elastic deflection (μm)
 F = load (N)

Rigidity of the roller rail system at preload C3

Standard roller runner block FNS R1851

Roller runner block mounted using 6 screws:

- ▶ 4 outer screws of strength class 12.9
- ▶ 2 centerline screws of strength class 8.8

Down load

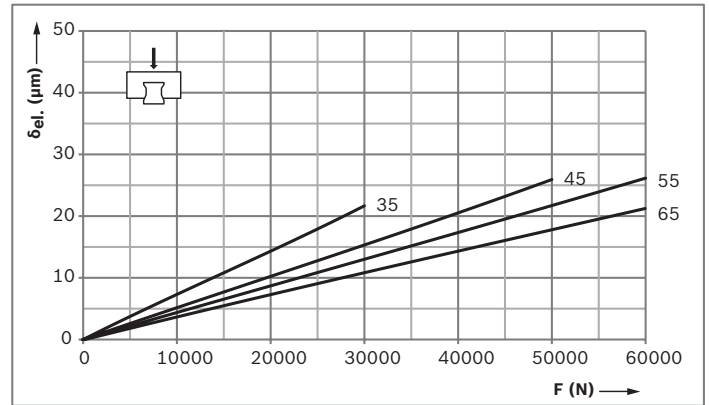

Lift-off load

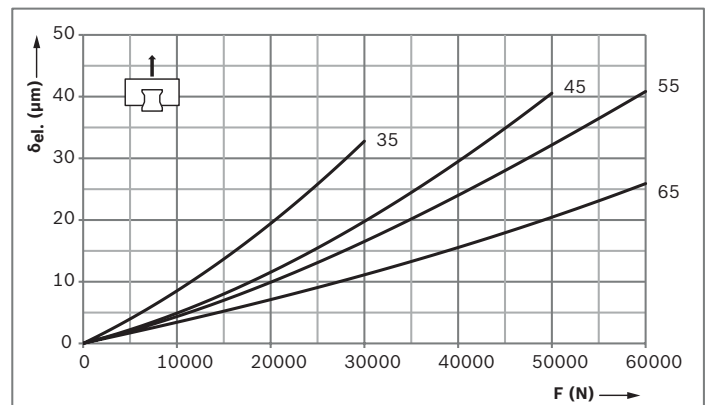

Side load

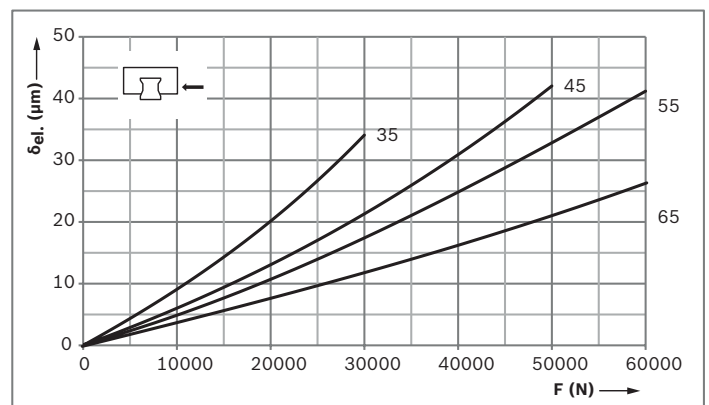

Preload class

C3 = preload (as per table for preload force F_{pr})

Key to graphs

$\delta_{el.}$ = elastic deflection (μm)
 F = load (N)

Rigidity of the Standard Roller Runner Blocks FLS

Rigidity of the roller rail system at preload C2

Standard roller runner block FLS R1853

Roller runner block mounted using 6 screws:

- ▶ 4 outer screws of strength class 12.9
- ▶ 2 centerline screws of strength class 8.8

Down load

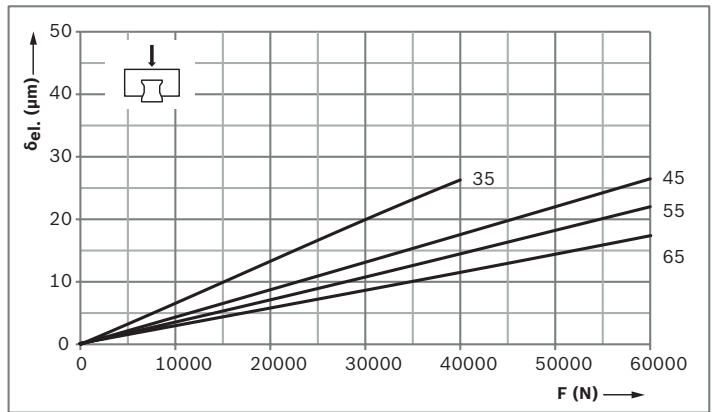

Lift-off load

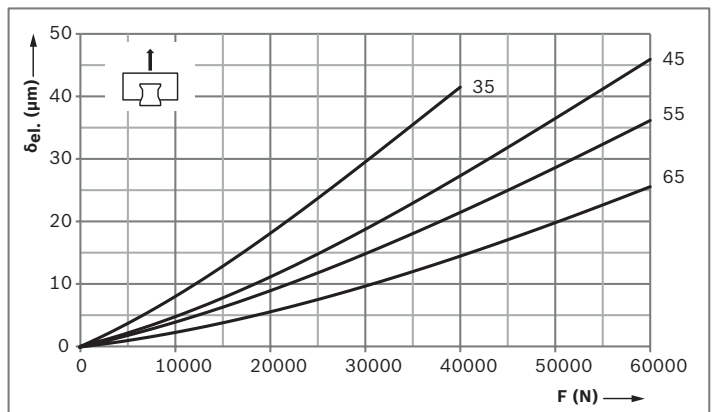

Side load

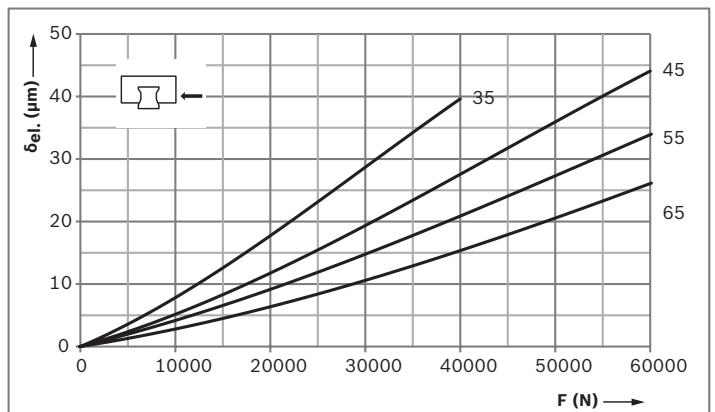

Preload class

C2 = preload (as per table for preload force F_{pr})

Key to graphs

$\delta_{el.}$ = elastic deflection (μm)
 F = load (N)

Rigidity of the roller rail system at preload C3

Standard roller runner block FLS R1853

Roller runner block mounted using 6 screws:

- ▶ 4 outer screws of strength class 12.9
- ▶ 2 centerline screws of strength class 8.8

Down load

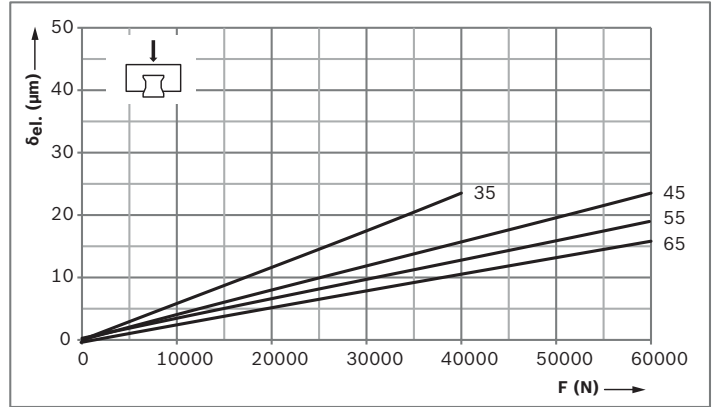

Lift-off load

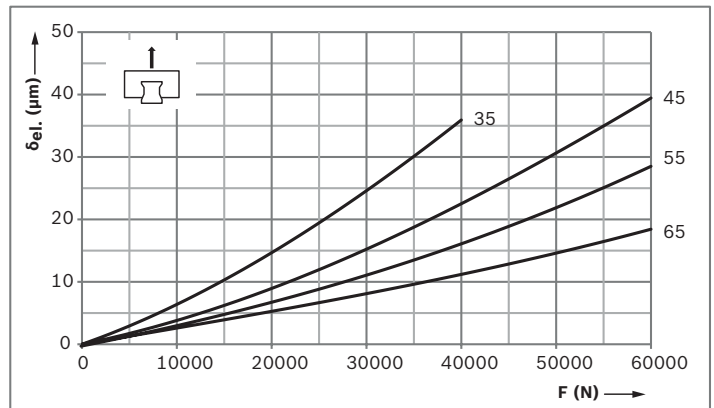

Side load

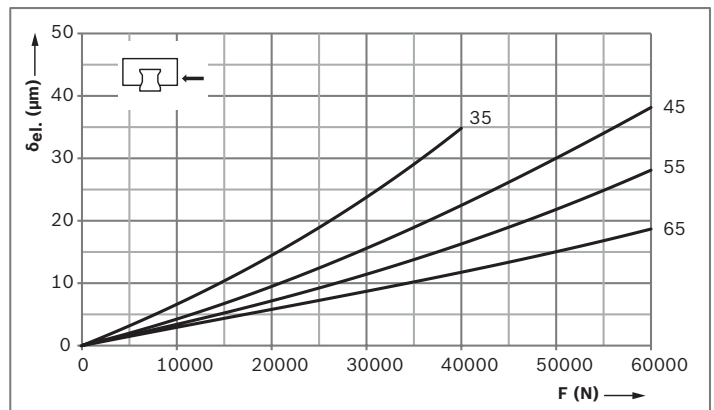

Preload class

C3 = preload (as per table for preload force F_{pr})

Key to graphs

δ_{el.} = elastic deflection (μm)
 F = load (N)

Rigidity of the Standard Roller Runner Blocks SNS/SNH

Rigidity of the roller rail system at preload C2

Standard roller runner block SNS R1822/SNH R1821

Roller runner block mounted using 6 screws of strength class 12.9

Down load

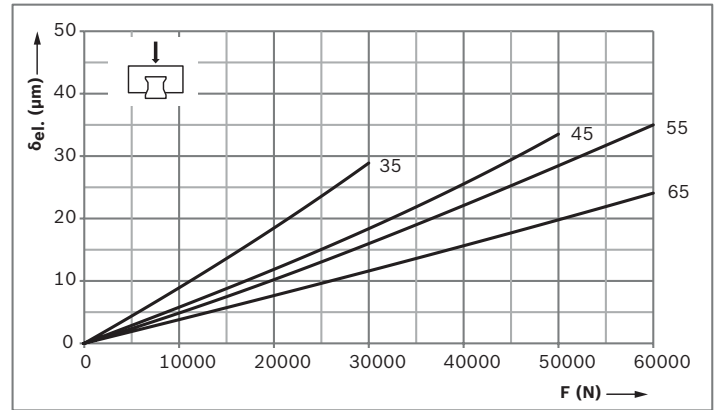

Lift-off load

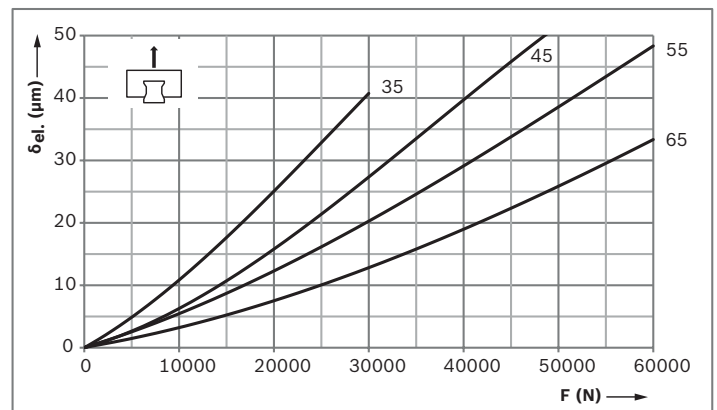

Side load

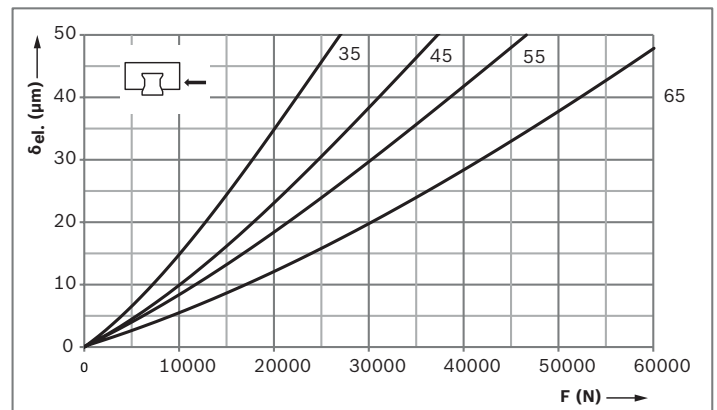

Preload class

C2 = preload (as per table for preload force F_{pr})

Key to graphs

$\delta_{el.}$ = elastic deflection (μm)
 F = load (N)

Rigidity of the roller rail system at preload C3

Standard roller runner block SNS R1822/SNH R1821

Roller runner block mounted using 6 screws of strength class 12.9

Down load

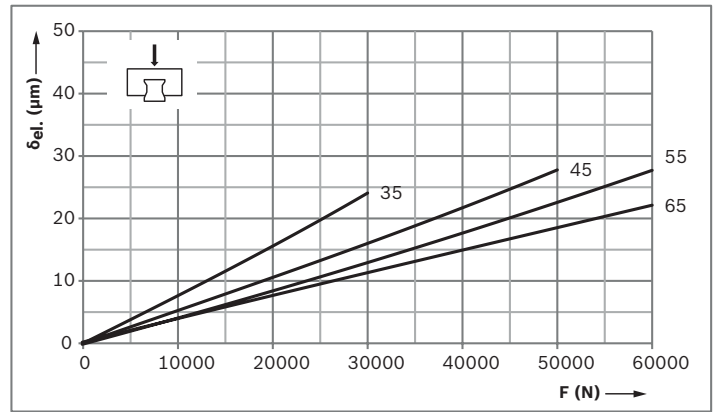

Lift-off load

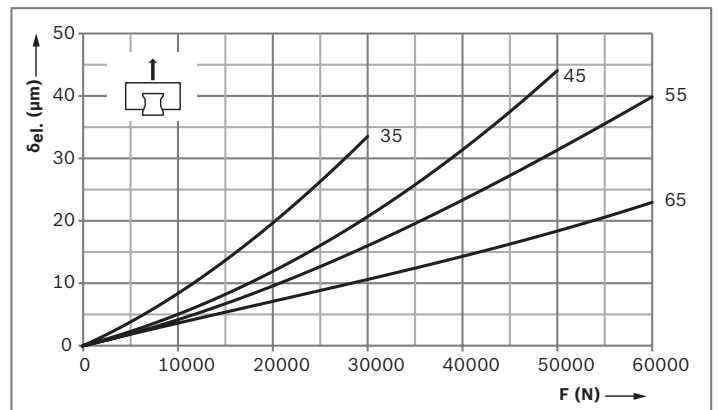

Side load

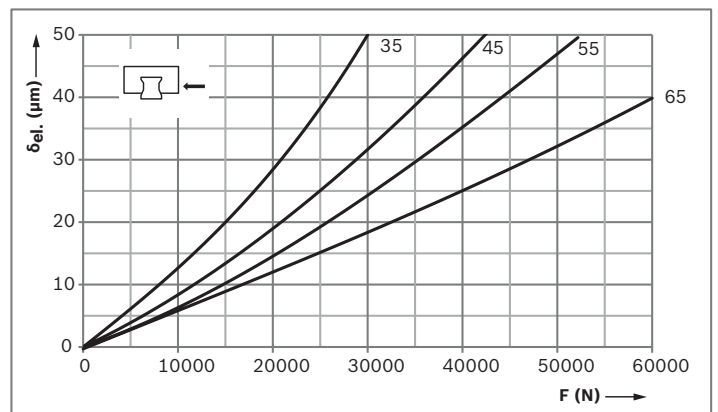

Preload class

C3 = preload (as per table for preload force F_{pr})

Key to graphs

δ_{el.} = elastic deflection (μm)
 F = load (N)

Rigidity of the Standard Roller Runner Blocks SLS/SLH

Rigidity of the roller rail system at preload C2

Standard roller runner block SLS R1823/SLH R1824

Roller runner block mounted using 6 screws of strength class 12.9

Down load

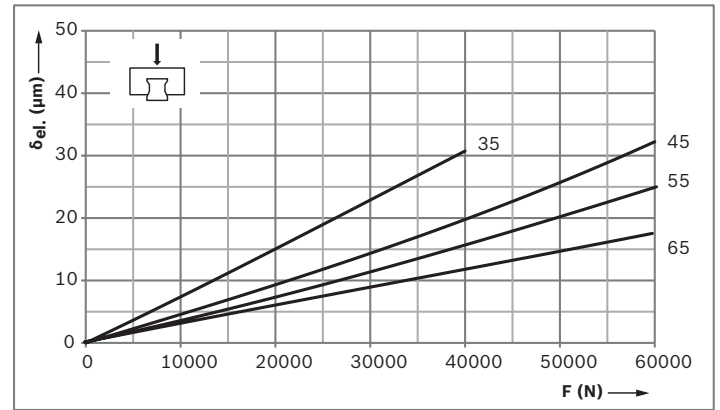

Lift-off load

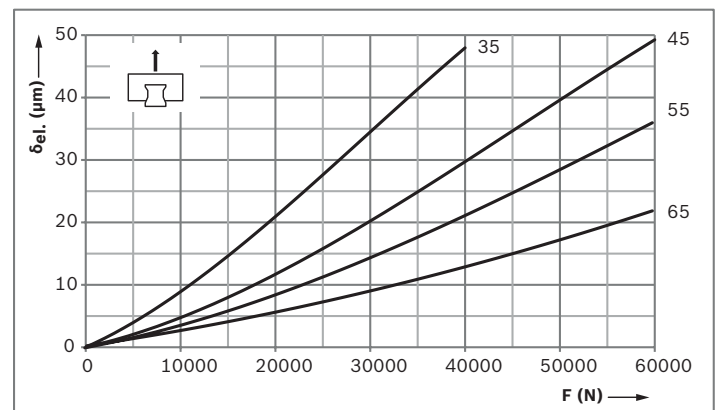

Side load

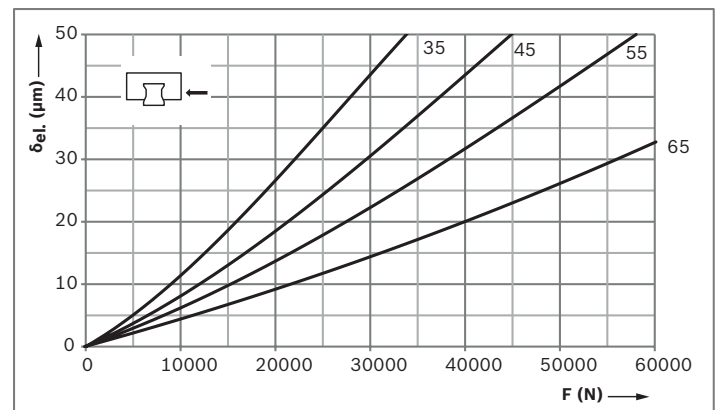

Preload class

C2 = preload (as per table for preload force F_{pr})

Key to graphs

$\delta_{el.}$ = elastic deflection (μm)
 F = load (N)

Rigidity of the roller rail system at preload C3

Standard roller runner block SLS R1823/SLH R1824

Roller runner block mounted using 6 screws of strength class 12.9

Down load

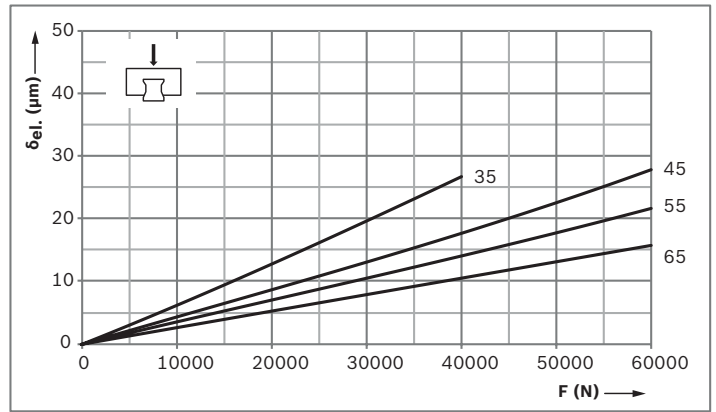

Lift-off load

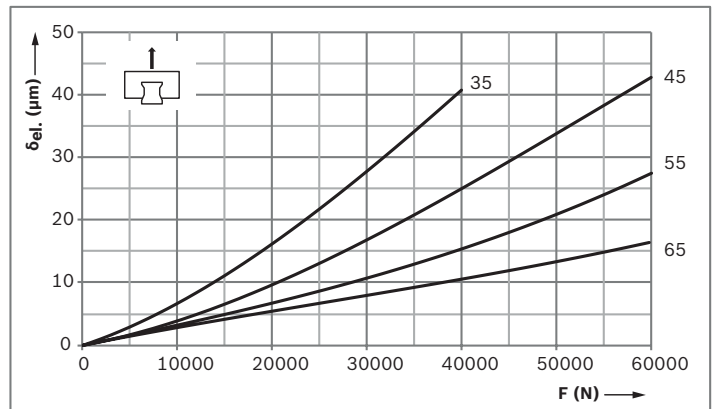

Side load

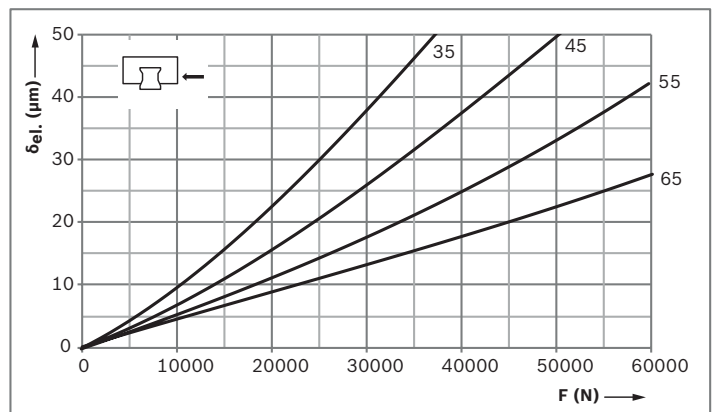

Preload class

C3 = preload (as per table for preload force F_{pr})

Key to graphs

δ_{el.} = elastic deflection (μm)
 F = load (N)

Rigidity of the Wide Roller Runner Blocks BLS

Rigidity of the roller rail system at preload C2

Wide roller runner block BLS R1872

Roller runner block mounted using 8 screws:

- ▶ only upper reference edges used
- ▶ All screws of strength class 12.9

Down load

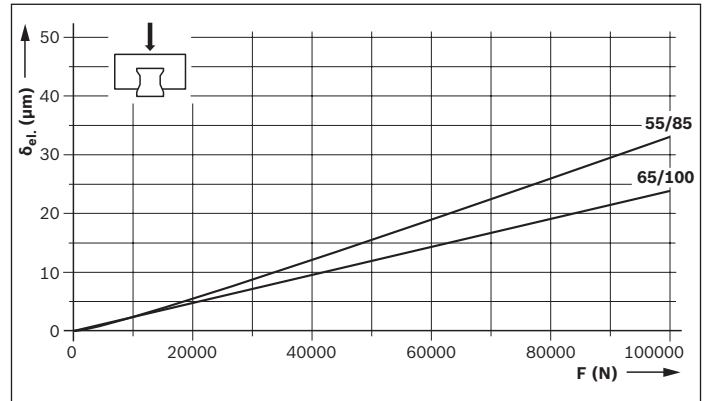

Lift-off load

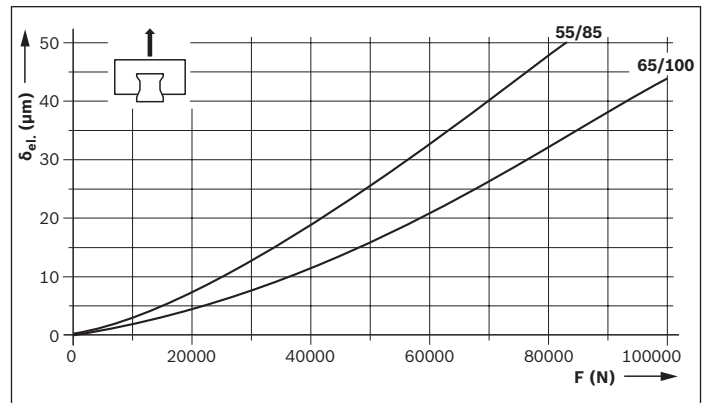

Side load

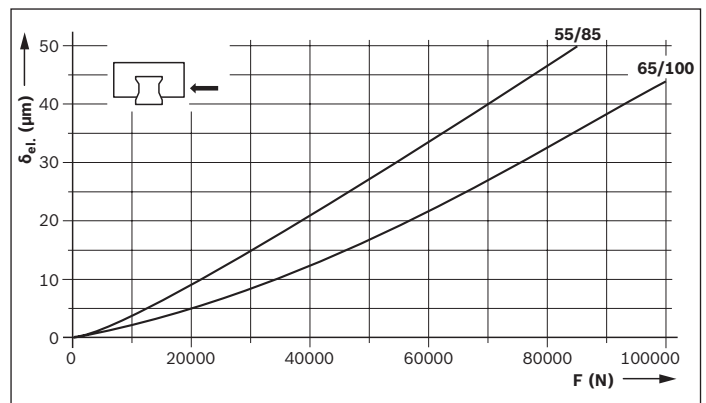

Preload class

C2 = preload (as per table for preload force F_{pr})

Key to graphs

$\delta_{el.}$ = elastic deflection (μm)
 F = load (N)

Rigidity of the roller rail system at preload C2

Wide roller runner block BLS R1872

Roller runner block mounted using 8 screws:

- ▶ all 4 reference edges (top and bottom) used
- ▶ All screws of strength class 12.9

Down load

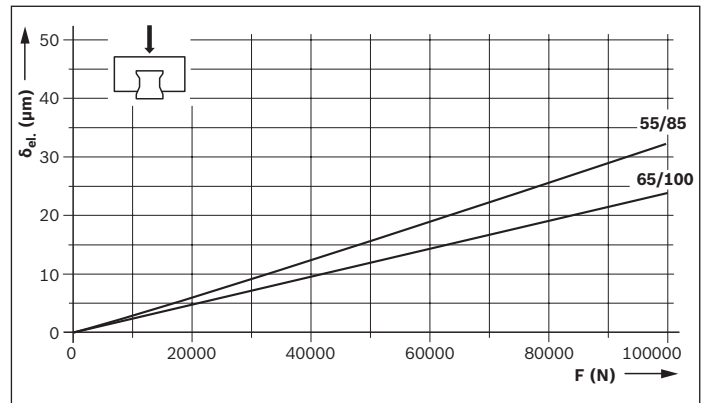

Lift-off load

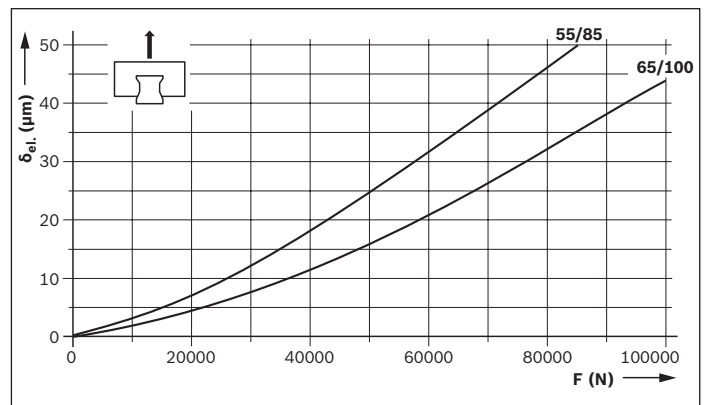

Side load

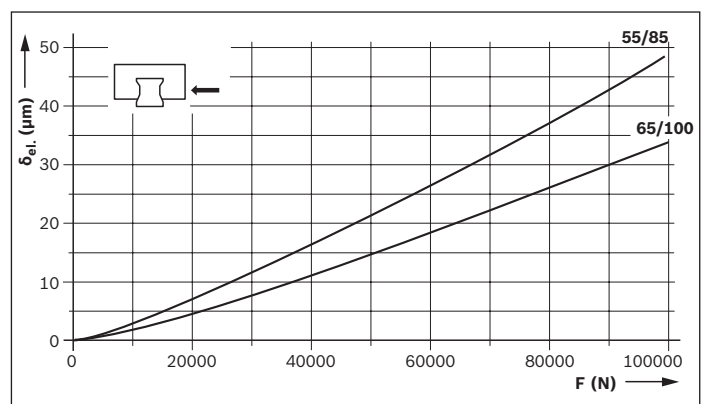

Preload class

C2 = preload (as per table for preload force F_{pr})

Key to graphs

δ_{ei} = elastic deflection (μm)
 F = load (N)

Rigidity of the Wide Roller Runner Blocks BLS

Rigidity of the roller rail system at preload C3

Wide roller runner block BLS R1872

Roller runner block mounted using 8 screws:

- ▶ only upper reference edges used
- ▶ All screws of strength class 12.9

Down load

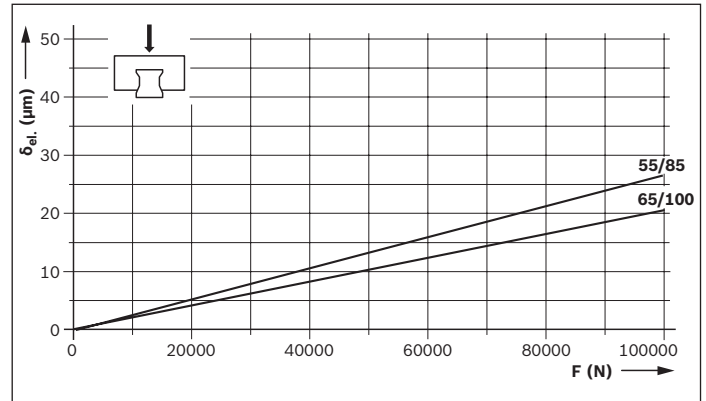

Lift-off load

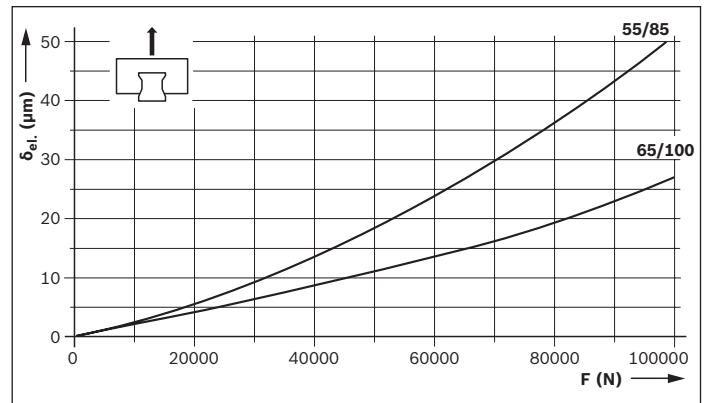

Side load

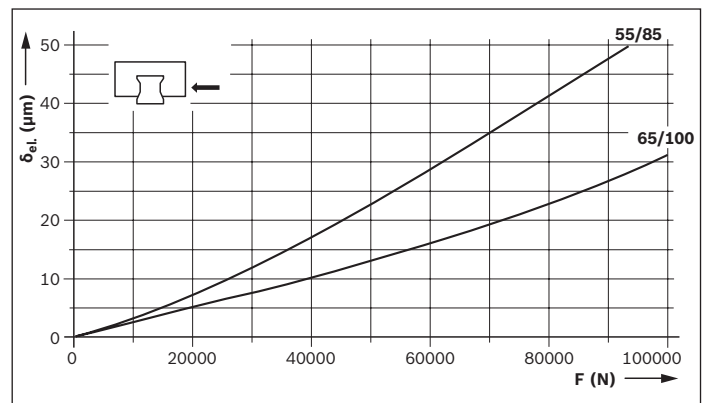

Preload class

C3 = preload (as per table for preload force F_{pr})

Key to graphs

$\delta_{el.}$ = elastic deflection (μm)
 F = load (N)

Rigidity of the roller rail system at preload C3

Wide roller runner block BLS R1872

Roller runner block mounted using 8 screws:

- ▶ all 4 reference edges (top and bottom) used
- ▶ All screws of strength class 12.9

Down load

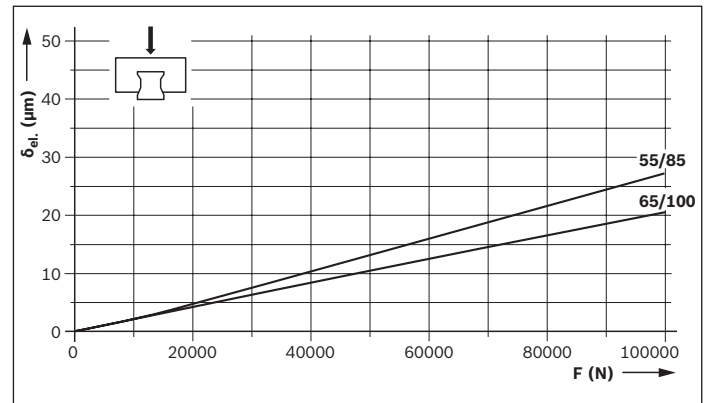

Lift-off load

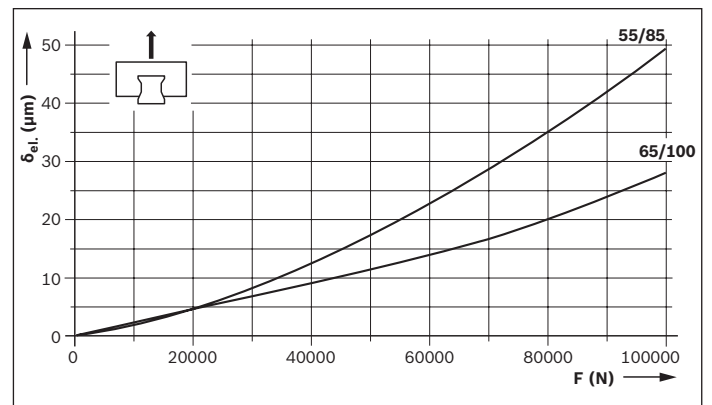

Side load

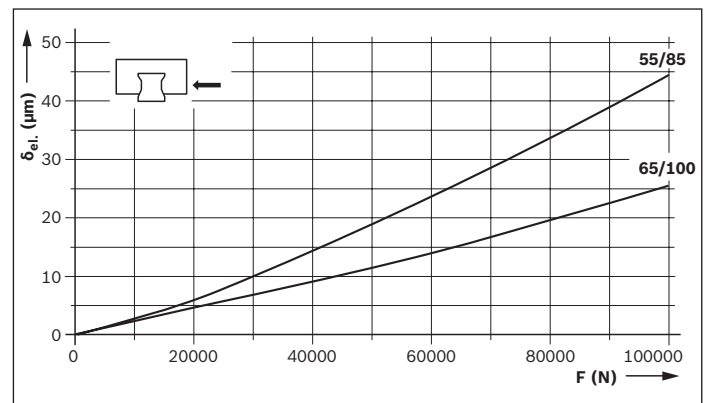

Preload class

C3 = preload (as per table for preload force F_{pr})

Key to graphs

$\delta_{el.}$ = elastic deflection (μm)
 F = load (N)

Rigidity of the Heavy Duty Roller Runner Blocks FNS

Rigidity of the roller rail system at preload C3

Heavy duty roller runner block FNS R1861

Roller runner block mounted using 9 screws:

- ▶ 6 outer screws of strength class 12.9
- ▶ 3 centerline screws of strength class 8.8

Down load

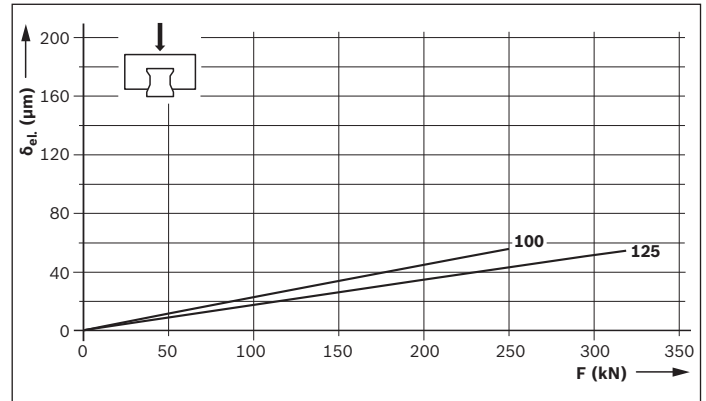

Lift-off load

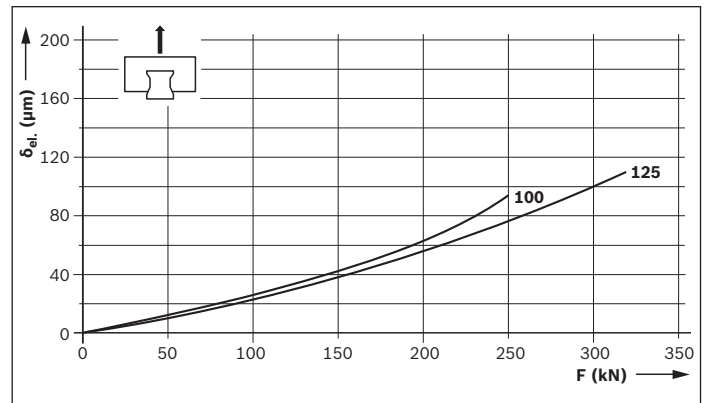

Side load

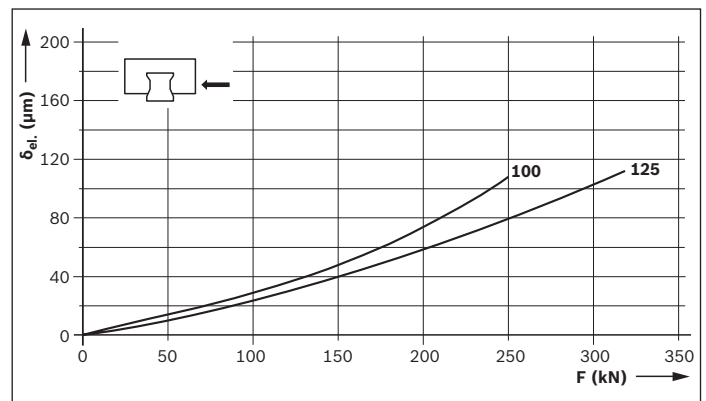

Preload class

C3= preload (as per table for preload force F_{pr})

Key to graphs

δ_{el} = elastic deflection (μm)
 F = load (N)

Rigidity of the Heavy Duty Roller Runner Block FLS

Rigidity of the roller rail system at preload C3

Heavy duty roller runner block FLS R1863

Roller runner block mounted using 9 screws:

- ▶ 6 outer screws of strength class 12.9
- ▶ 3 centerline screws of strength class 8.8

Down load

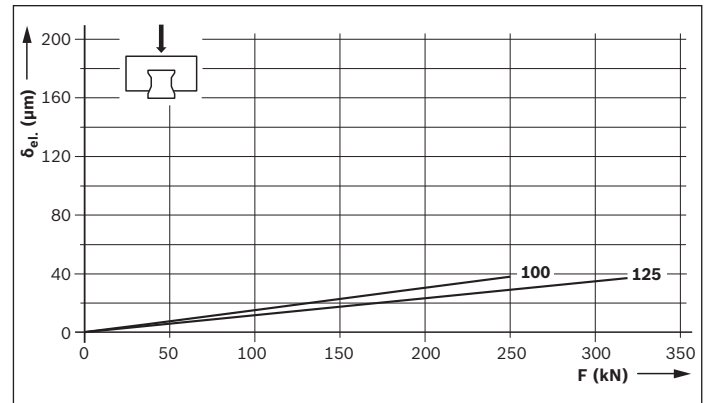

Lift-off load

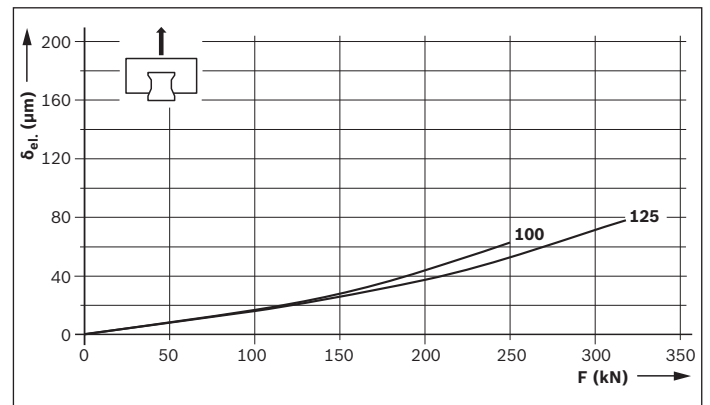

Side load

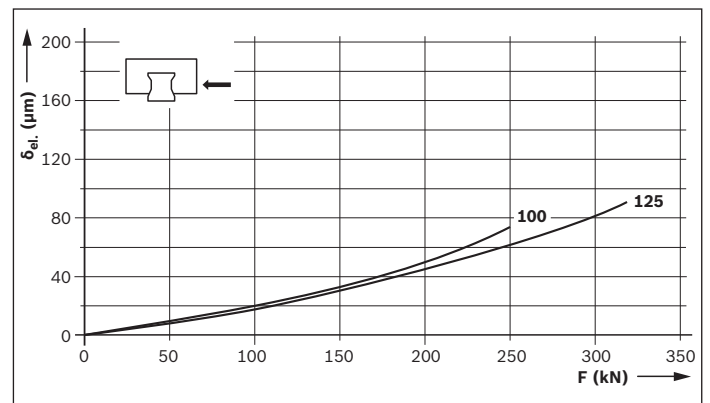

Preload class

C3 = preload (as per table for preload force F_{pr})

Key to graphs

δ_{el.} = elastic deflection (μm)
 F = load (N)

Rigidity of the Heavy Duty Roller Runner Blocks FXS

Rigidity of the roller rail system at preload C2

Heavy duty roller runner block FXS R1854

Roller runner block mounted using 6 screws:

- ▶ 4 screws of strength class 12.9
- ▶ 2 screws of strength class 8.8

Down load

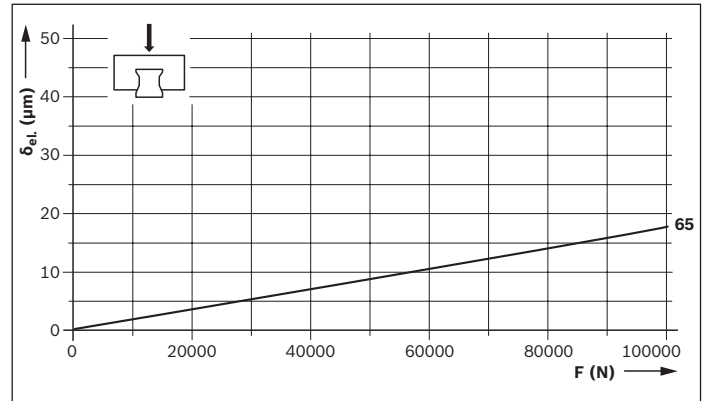

Lift-off load

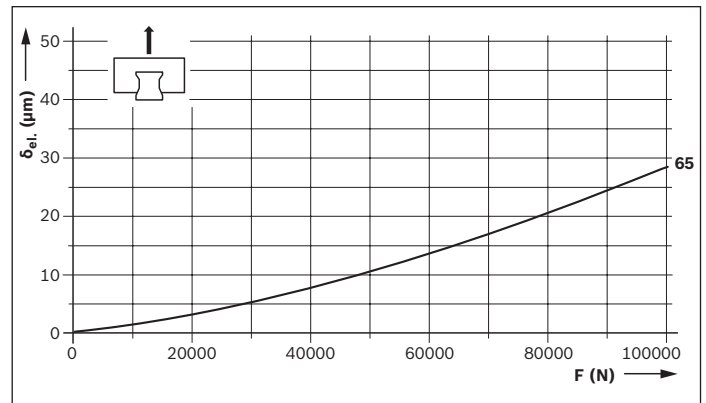

Side load

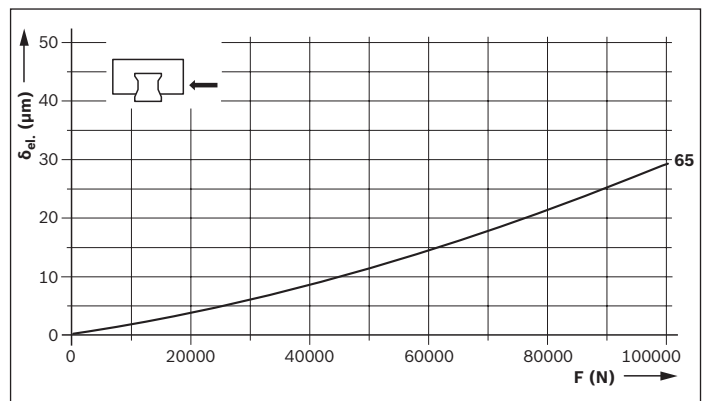

Preload class

C2 = preload (as per table for preload force F_{pr})

Key to graphs

$\delta_{el.}$ = elastic deflection (μm)
 F = load (N)

Rigidity of the roller rail system at preload C3

Heavy duty roller runner block FXS R1854

Roller runner block mounted using 6 screws:

- ▶ 4 screws of strength class 12.9
- ▶ 2 screws of strength class 8.8

Down load

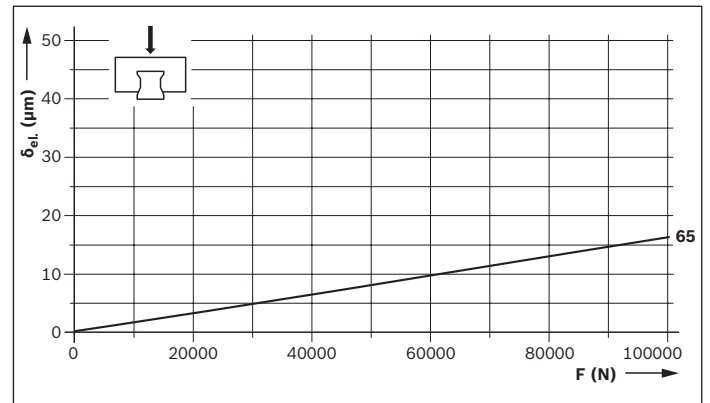

Lift-off load

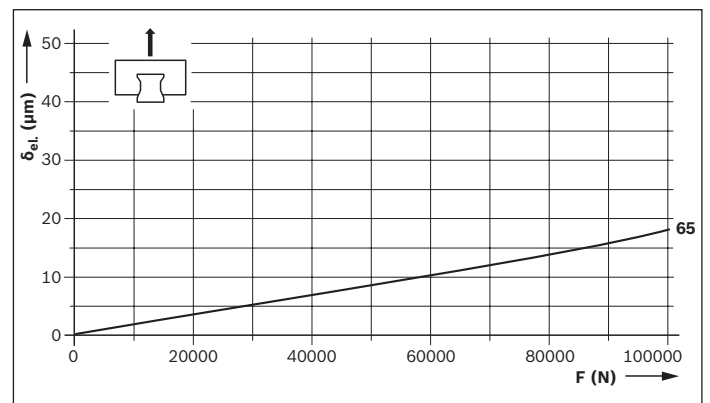

Side load

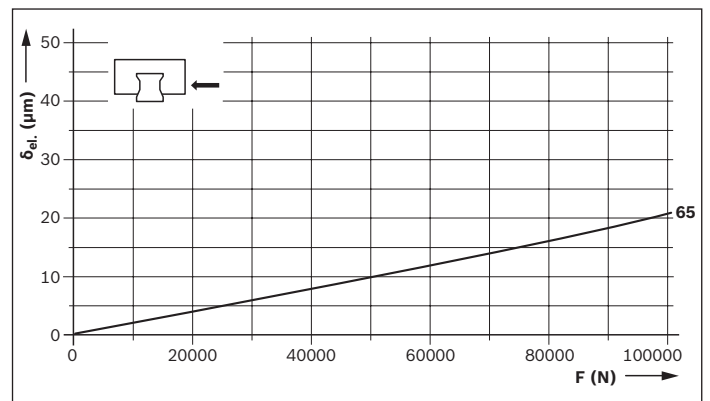

Preload class

C3 = preload (as per table for preload force F_{pr})

Key to graphs

$\delta_{el.}$ = elastic deflection (μm)
 F = load (N)

Accuracy Classes

Accuracy classes and their tolerances for standard roller rail systems

Standard roller rail systems are offered in up to five different accuracy classes.

Heavy duty roller rail systems are offered in up to three accuracy classes.

For details of the available roller runner blocks and roller guide rails, see the “Part numbers” tables.

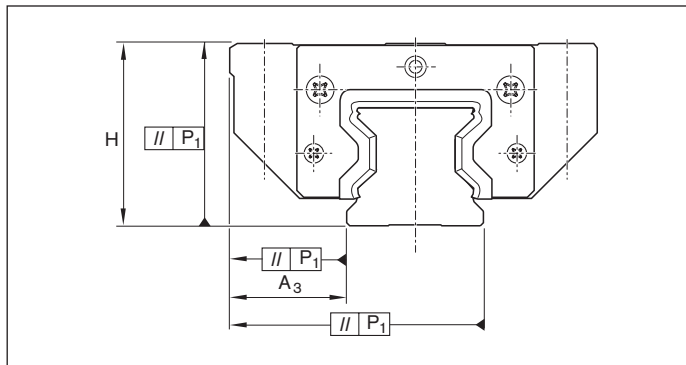

Built-in interchangeability through precision machining

Rexroth manufactures its roller guide rails and roller runner blocks with such high precision, especially in the roller track zone, that each individual component element can be replaced by another at any time.

For example, a roller runner block can be used without problems on various roller guide rails of the same size. Similarly, different roller runner blocks can also be used on one and the same roller guide rail.

	H, A ₃	ΔH, ΔA ₃
Measured at middle of runner block	For any roller runner block/guide rail combination at any position on rail	For different roller runner blocks at same position on rail

Standard and heavy duty roller rail systems, steel version

Accuracy classes	Dimensional tolerances (μm)		Max. difference in dimension H and A ₃ on one guide rail (μm)	
	H	A ₃	ΔH, ΔA ₃	
H		±40	±20	15
P		±20	±10	7
SP		±10	±7	5
GP¹⁾		(±10) 10	±7	5
UP		±5	±5	3

1) Dimension H: (±10) sorted by height (GP) to 10 μm (see “Combinations of accuracy classes”)

Standard and heavy duty roller rail systems, Resist CR, hard chrome plated

Accuracy classes	Dimensional tolerances (μm)				Max. difference in dimension H and A ₃ on one guide rail (μm)	
	H		A ₃		ΔH, ΔA ₃	
	RB/GR	GR	RB/GR	GR	RB/GR	GR
H	+47 -38	+44 -39	±23	+19 -24	18	15
P	+27 -18	+24 -19	±13	+9 -14	10	7
SP	+17 -8	+14 -9	±10	+6 -11	8	5

Accuracy classes and their tolerances for wide roller rail systems

Wide roller rail systems are offered in up to three different accuracy classes. For details of the available roller runner blocks and roller guide rails, see the “Part numbers” tables.

Key to graphs

H = height tolerance (µm)
 A₃ = lateral tolerance (µm)
 P₁ = parallelism offset (µm)
 L = rail length (mm)

Abbreviations

RB/GR = roller runner block and roller guide rail hard chrome plated
 GR = only roller guide rail hard chrome plated

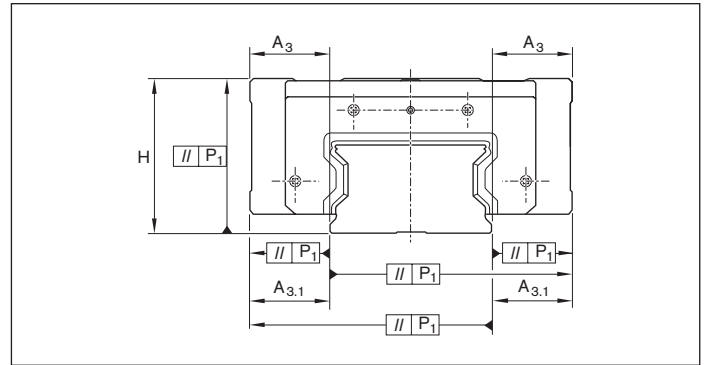

	H	A ₃	A _{3.1}	ΔH, ΔA ₃	ΔA _{3.1}
Measured at middle of runner block	For any roller runner block/guide rail combination at any position on rail			For different roller runner blocks at same position on rail	

Wide roller rail systems, steel version

Accuracy classes	Dimensional tolerances (µm)						Max. difference in dimension H and A ₃ on one guide rail (µm)			
	H		A ₃		A _{3.1}		ΔH, ΔA ₃		ΔA _{3.1}	
H	±40		±20		±20		+26/-24		15 17	
P	±20		±10		±10		+15/-13		7 9	
SP	±10		±7		±7		+12/-10		5 7	

Wide roller rail systems, Resist CR, hard chrome plated

Accuracy classes	Dimensional tolerances (µm)						Max. difference in dimension H and A ₃ on one guide rail (µm)			
	H		A ₃		A _{3.1}		ΔH, ΔA ₃		ΔA _{3.1}	
	RB/GR	GR	RB/GR	GR	RB/GR	GR	RB/GR	GR	RB/GR	GR
H	+47 -38	+44 -39	±23	+19 -24	+29 -27	+25 -28	18 15		20 17	
P	+27 -18	+24 -19	±13	+9 -14	+18 -16	+14 -17	10 7		12 9	
SP	+17 -8	+14 -9	±10	+9 -14	+18 -16	+14 -17	10 7		12 9	

Accuracy Classes

Parallelism offset P_1 of the roller rail system in service

Values measured at middle of runner block for roller rail systems without surface coating

For hard chrome plated roller guide rails the values may increase by up to $2 \mu\text{m}$.

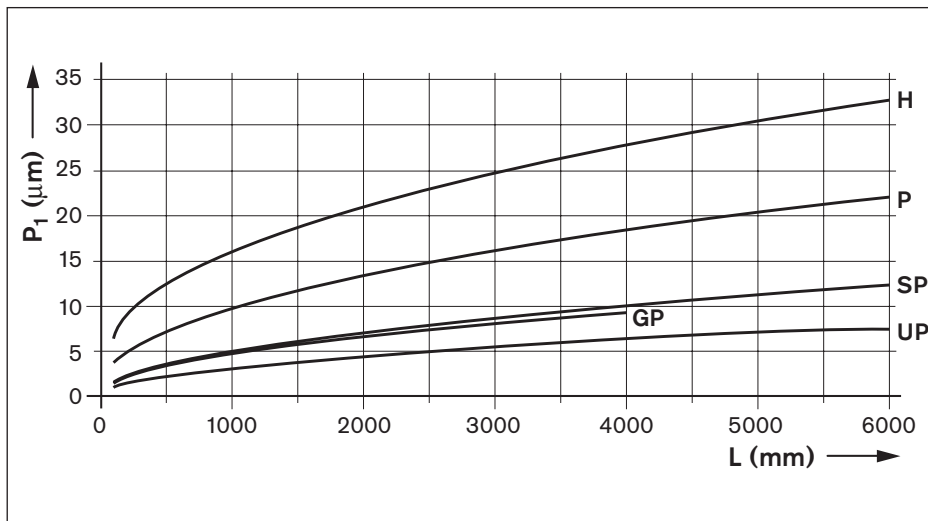

Key to graphs

P_1 = parallelism offset (μm)
L = rail length (mm)

Combinations of accuracy classes

Tolerances for combination of accuracy classes

Accuracy classes roller runner blocks	Dimensional tolerances (μm)	Accuracy classes roller guide rails				
		H	P	SP	GP	UP
H	Tolerance for dimension H	± 40	± 24	± 15	–	± 11
	Tolerance for dimension A_3	± 20	± 14	± 12	–	± 11
	Max. difference in dimension H and A_3 on one rail	15	15	15	–	15
P	Tolerance for dimension H	± 36	± 20	± 11	–	± 7
	Tolerance for dimension A_3	± 16	± 10	± 8	–	± 7
	Max. difference in dimension H and A_3 on one rail	7	7	7	–	7
SP	Tolerance for dimension H	± 35	± 19	± 10	$(\pm 10)^1 \pm 5$	± 6
	Tolerance for dimension A_3	± 15	± 9	± 7	± 7	± 6
	Max. difference in dimension H and A_3 on one rail	5	5	5	5	5
UP	Tolerance for dimension H	± 34	± 18	± 9	± 4	± 5
	Tolerance for dimension A_3	± 14	± 8	± 6	± 6	± 5
	Max. difference in dimension H and A_3 on one rail	3	3	3	3	3

1) Dimension H: (± 10) sorted by height (GP) to $10 \mu\text{m}$ (see “Combination: roller runner blocks SP with roller guide rails GP”)

Combination: roller runner blocks SP with roller guide rails GP

Dimension H (± 10) sorted by height (GP) to $\pm 5 \dots 10 \mu\text{m}$:

Applies for any combination of roller runner blocks with accuracy class SP and roller guide rails R1805 .68 .. with the same sorting, e.g. $-1^{\pm 2.5} \mu\text{m}$, over the entire rail length. Sorting code on the roller guide rail and the additional label, e.g. GP -1, GP +3, etc.

When ordering, please state the quantity per sorting dimension, e.g. 2 pcs per sorting dimension.

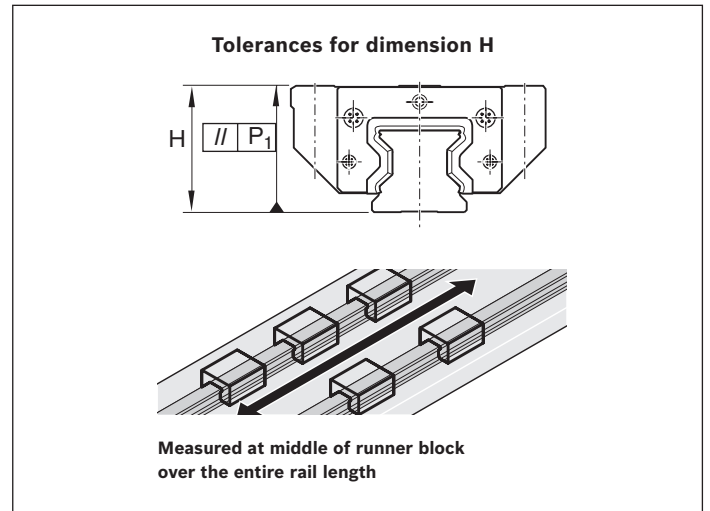

Height sorting of the roller guide rails

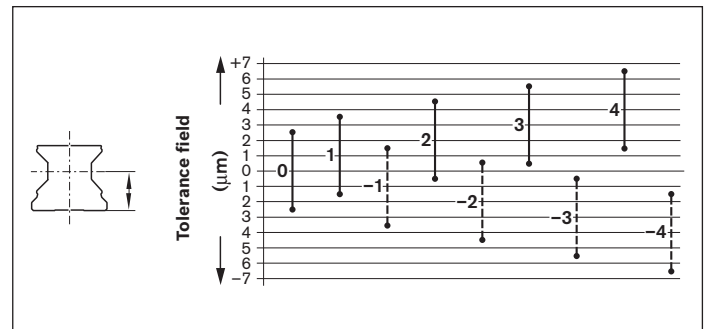

Recommendations for combining accuracy classes

Recommended for **close roller runner block spacing** and short strokes:

Roller runner block in higher accuracy class than roller guide rail.

Recommended for **large roller runner block spacing** and long strokes:

Roller guide rail in higher accuracy class than roller runner block.

Travel accuracy

Perfected roller entry and exit zones in the roller runner blocks and optimized spacing of the mounting screws in the roller guide rails provide unmatched travel accuracy with very low pulsation.

Important note

For roller runner blocks and roller guide rails in Resist CR, hard chrome plated, different tolerances apply for the dimensions H and A_3 (see “Accuracy classes and their tolerances”).

These high accuracy systems are especially suitable for high-precision machining processes, measurement systems, high-precision scanners, EDM equipment, etc.

Preload

Definition of the preload class

Preload force relative to the dynamic load capacity C of the respective roller runner block.

Selection of the preload class

Code	Application area
C1 C4 C5	Special version on request
C2	For precise guide systems with both high external loading and high demands on overall rigidity; also recommended for single rail systems. Above average moment loads can be absorbed without significant elastic deflection. Further improved overall rigidity with only medium moment loads.
C3	For highly rigid guide systems such as precision machine tools, etc. Above average loads and moments can be absorbed with the least possible elastic deflection. Roller runner blocks with preload C3 available in accuracy classes P, SP (GP) and UP only.

Preload force F_{pr}

Roller runner blocks			Size	25 ³⁾	30 ³⁾	35	45	55	65	100	125
		Design type	Preload class	Preload force F_{pr} (N)							
Standard roller runner blocks made of steel¹⁾ and Resist CR²⁾	R1851 R1822 R1821 R1861	FNS SNS SNH	C1	830	1270	1680	2930	3860	6520		
			C2	2240	3430	4510	7890	10400	17600	36900	60600
			C3	3640	5560	7320	12800	16800	28500	59900	98400
			C4	4770	7290	9610	16800	22100	37400		
			C5	5610	8570	11300	19700	26000	43900		
	R1853 R1823 R1824 R1863	FLS SLS SLH	C1	1010	1610	2060	3640	4790	8140		
			C2	2720	4320	5540	9790	12900	21900	50600	81600
			C3	4420	7010	8990	15900	20900	35500	82200	132600
			C4	5800	9200	11800	20800	27400	46600		
			C5	6810	10800	13900	24500	32200	54700		
Roller runner blocks made of steel¹⁾	R1854	FXS	C2						29300		
			C3						47700		
Wide roller runner blocks			Size					55/85	65/100		
				Preload force F_{pr} (N)							
Roller runner blocks made of steel¹⁾ and Resist CR²⁾	R1872	BLS	C2					13200	21200		
			C3					21500	34500		

1) All steel parts made of carbon steel

2) Runner block body made of steel with matte silver hard-chrome plated corrosion-resistant coating

3) In preparation

Recommended preload and accuracy class combinations

Recommended for preload C2:
Accuracy classes H and P

Recommended for preload C3:
Accuracy classes P and SP (GP)

Combination of hard chrome plated roller runner blocks with hard chrome plated roller guide rails

On the combination of hard chrome plated roller runner blocks with preload C2 or C3 and hard chrome plated roller guide rails, the preload increases by approx. half a preload class.

Product Description

Characteristic features

- ▶ RSHP roller runner blocks are suitable for all typical applications as well as for special installation and usage conditions and for special working environments such that additional special versions are unnecessary
- ▶ High torque capacity
- ▶ Same high load capacities in all four major planes of load application
- ▶ Maximum rigidity under load from all directions through two additional mounting screw holes at the center of the roller runner block
- ▶ Unrestricted interchangeability
- ▶ Unlimited combinability: any roller guide rail version can be paired with any roller runner block version
- ▶ Accessories can be simply attached to the ends of the roller runner block

Further highlights

- ▶ Lube ports on all sides for maximum ease of maintenance
- ▶ Novel lube duct design minimizes lubricant consumption
- ▶ Smooth running thanks to optimized roller recirculation and guidance
- ▶ Attachments can be mounted to roller runner blocks from above or below
- ▶ Maximum rigidity under load from all directions through two additional mounting screw holes at the center of the roller runner block
- ▶ High torque capacity
- ▶ Further optimized entry zone geometry and high number of rollers per track minimize variation in elastic deflection and provide maximum precision travel accuracy
- ▶ The roller runner block simply slides off its arbor and onto the rail
- ▶ Integrated all-around sealing as standard

Optional versions

- ▶ Corrosion-resistant roller runner blocks and guide rails Resist CR, hard chrome plated, come in accuracy class H; accuracy classes P and SP on request

Design types high precision roller runner blocks



FNS – Flanged, normal, standard height



FLS – Flanged, long, standard height



SNS – Slimline, normal, standard height

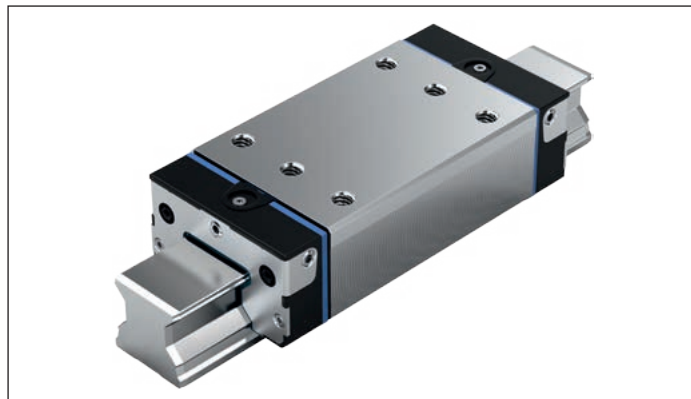

SLS – Slimline, long, standard height

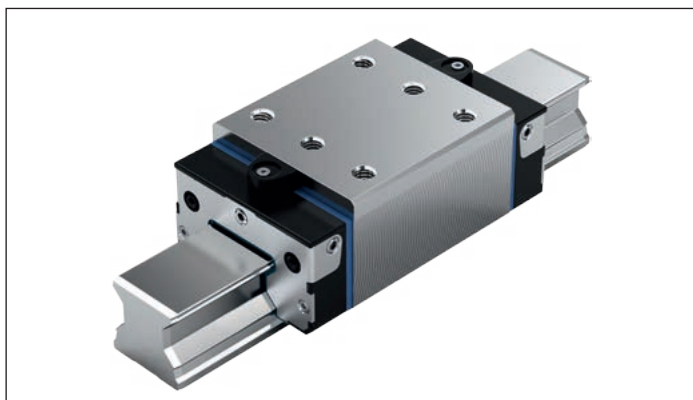

SNH – Slimline, normal, high



SLH – Slimline, long, high

FNS – Flanged, normal, standard height

R1851 ... 2X



Dynamic characteristics

Speed: $v_{\max} = 4 \text{ m/s}$

Acceleration: $a_{\max} = 150 \text{ m/s}^2$

Recommended preload and accuracy class combinations

- ▶ For preload class C2: H and P (preferred)
- ▶ For preload class C3: P and SP

Part numbers

Size	Roller runner block with size	Preload class		Accuracy class				Material
		C2	C3	H	P	SP	UP	
25 ^{*)}	R1851 2	2		3	2	1	9	2X
			3		2	1	9	2X
30 ^{*)}	R1851 7	2		3	2	1	9	2X
			3		2	1	9	2X
35	R1851 3	2		3	2	1	9	2X
			3		2	1	9	2X
45	R1851 4	2		3	2	1	9	2X
			3		2	1	9	2X
55	R1851 5	2		3	2	1	9	2X
			3		2	1	9	2X
65 ^{*)}	R1851 6	2		3	2	1	9	2X
			3		2	1	9	2X

*) In preparation

Technical data

Size	Mass (kg)	Load capacities ¹⁾ (N)		Torsional load moments ¹⁾ (Nm)		Longitudinal load moments ¹⁾ (Nm)	
		C	C ₀	M _t	M _{t0}	M _L	M _{L0}
25	0.73	30300	59500	390	770	300	580
30	1.25	46300	92100	780	1550	500	1000
35	2.15	61000	119400	1210	2370	760	1480
45	4.05	106600	209400	2640	5180	1650	3240
55	5.44	140400	284700	4120	8350	2610	5290
65	10.72	237200	456300	8430	16210	5260	10120

1) Determination of the dynamic load capacities and moments is based on a travel life of 100,000 m per ISO 14728 Part 1. Often only 50,000 m are actually stipulated. If this is the case, for comparison purposes: Multiply values C, M_t and M_L from the table by 1.23.

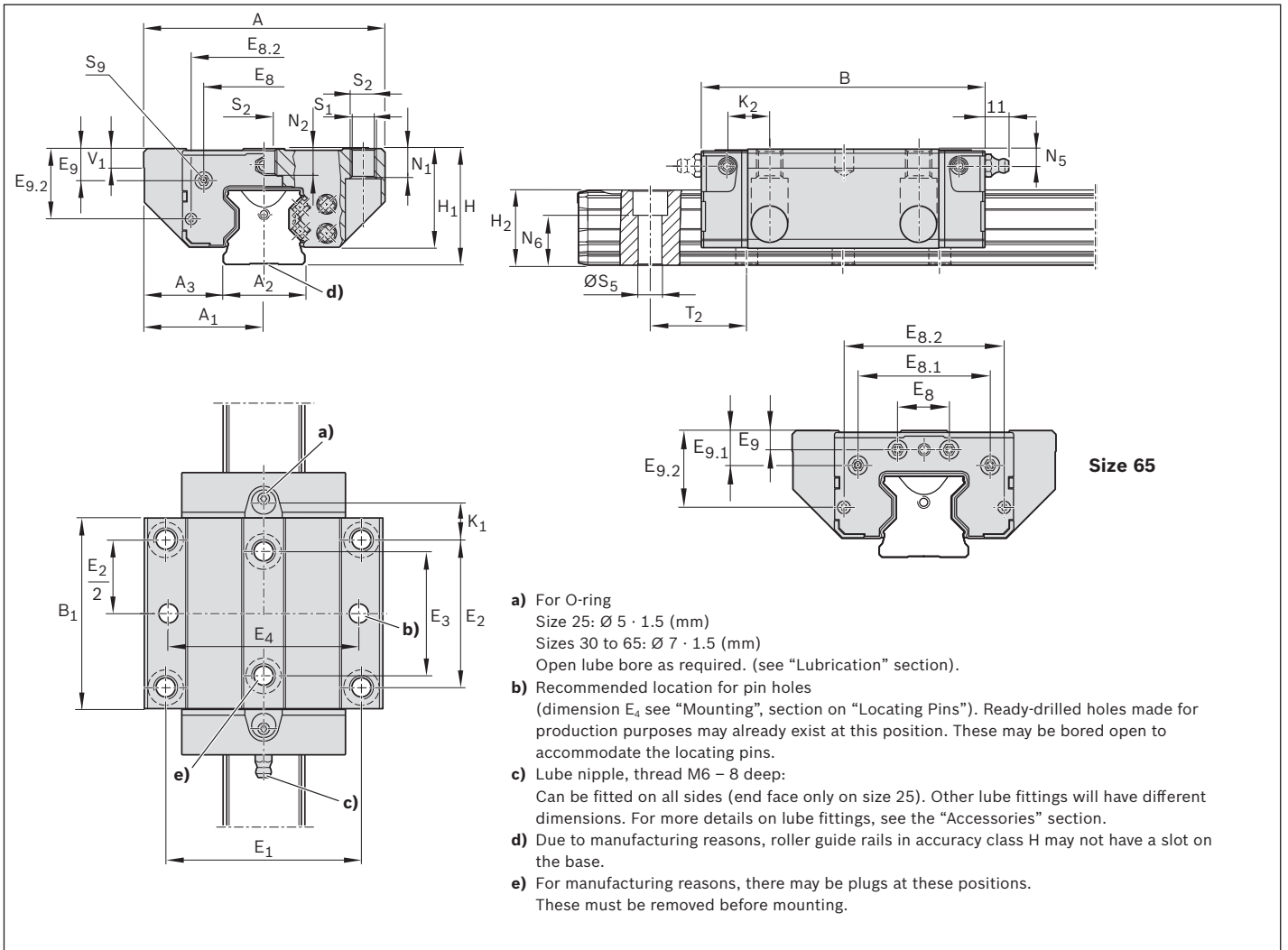
Dimensions (mm)

Size	A	A ₁	A ₂	A ₃	B	B ₁	E ₁	E ₂	E ₃	E ₄	E ₈	E _{8.1}	E _{8.2}	E ₉	E _{9.1}	E _{9.2}
25	70.00	35.00	23.00	23.50	97.00	63.50	57.00	45.00	40.00	55.00	33.40	–	40.20	8.30	–	21.40
30	90.00	45.00	28.00	31.00	106.40	71.00	72.00	52.00	44.00	70.00	43.00	–	51.00	12.00	–	25.50
35	100.00	50.00	34.00	33.00	118.00	79.60	82.00	62.00	52.00	80.00	50.30	–	60.50	13.10	–	29.10
45	120.00	60.00	45.00	37.50	147.00	101.50	100.00	80.00	60.00	98.00	62.90	–	72.00	16.70	–	36.50
55	140.00	70.00	53.00	43.50	170.65	123.10	116.00	95.00	70.00	114.00	74.20	–	81.60	18.85	–	40.75
65	170.00	85.00	63.00	53.50	207.30	146.00	142.00	110.00	82.00	140.00	35.00	93.00	106.00	9.30	26.00	55.00

Size	H	H ₁	H ₂ ²⁾	H ₂ ³⁾	K ₁	K ₂	N ₁	N ₂	N ₅	N ₆ ^{4)0.5}	Ø S ₁	S ₂	Ø S ₅	S ₉ ⁴⁾	T ₂ ⁵⁾	V ₁
25	36.00	30.00	23.60	23.40	14.05	–	9.00	7.3	5.50	14.30	6.70	M8	7.00	M3-6.5 deep	30.00	7.50
30	42.00	36.60	28.00	27.80	17.00	18.38	11.80	–	6.00	16.80	8.50	M10	9.00	M3-5 deep	40.00	7.80
35	48.00	41.00	31.10	30.80	15.55	17.40	12.00	11.0	7.00	19.40	8.50	M10	9.00	M3-6 deep	40.00	8.00
45	60.00	51.00	39.10	38.80	17.45	20.35	15.00	13.5	8.00	22.40	10.40	M12	14.00	M4-9 deep	52.50	10.00
55	70.00	58.00	47.85	47.55	21.75	24.90	18.00	13.7	9.00	28.70	12.40	M14	16.00	M5-8 deep	60.00	12.00
65	90.00	76.00	58.15	57.85	30.00	33.00	23.00	21.5	9.30	36.50	14.60	M16	18.00	M4-8 deep	75.00	15.00

- 2) Dimension H₂ with cover strip
- 3) Dimension H₂ without cover strip
- 4) Thread for attachments
- 5) Dimension T₂ = hole spacing in the roller guide rail

FLS – Flanged, Long, Standard Height

R1853 ... 2X

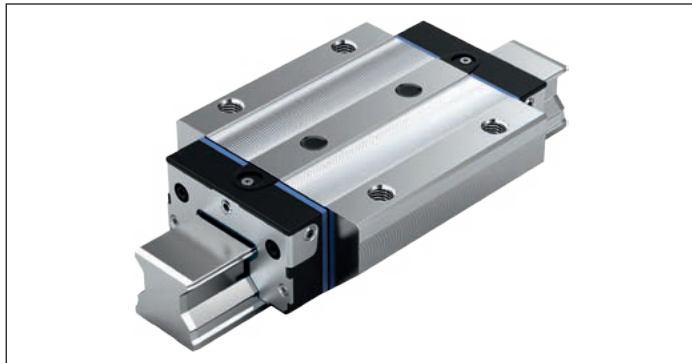

Dynamic characteristics

Speed: $v_{\max} = 4 \text{ m/s}$

Acceleration: $a_{\max} = 150 \text{ m/s}^2$

Recommended preload and accuracy class combinations







- ▶ For preload class C2: H and P (preferred)
- ▶ For preload class C3: P and SP

Part numbers

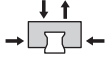
Size	Roller runner block with size	Preload class		Accuracy class				Material CS
		C2	C3	H	P	SP	UP	
25 ^{*)}	R1853 2	2		3	2	1	9	2X
			3		2	1	9	2X
30 ^{*)}	R1853 7	2		3	2	1	9	2X
			3		2	1	9	2X
35	R1853 3	2		3	2	1	9	2X
			3		2	1	9	2X
45	R1853 4	2		3	2	1	9	2X
			3		2	1	9	2X
55	R1853 5	2		3	2	1	9	2X
			3		2	1	9	2X
65 ^{*)}	R1853 6	2		3	2	1	9	2X
			3		2	1	9	2X

*) In preparation

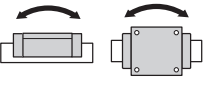
Technical data

Size	Mass (kg)	Load capacities ¹⁾ (N)		Torsional load moments ¹⁾ (Nm)		Longitudinal load moments ¹⁾ (Nm)	
							
	m	C	C ₀	M _t	M _{to}	M _L	M _{L0}
25	0.93	36800	76400	480	990	470	970
30	1.67	58400	123900	980	2090	870	1840
35	2.70	74900	155400	1490	3080	1220	2530
45	5.15	132300	276400	3270	6830	2690	5630
55	7.15	174000	374900	5100	10990	4420	9520
65	14.18	295900	606300	10510	21540	8870	18180

1) Determination of the dynamic load capacities and moments is based on a travel life of 100,000 m per ISO 14728 Part 1. Often only 50,000 m are actually stipulated. If this is the case, for comparison purposes: Multiply values C, M_t and M_L from the table by 1.23.

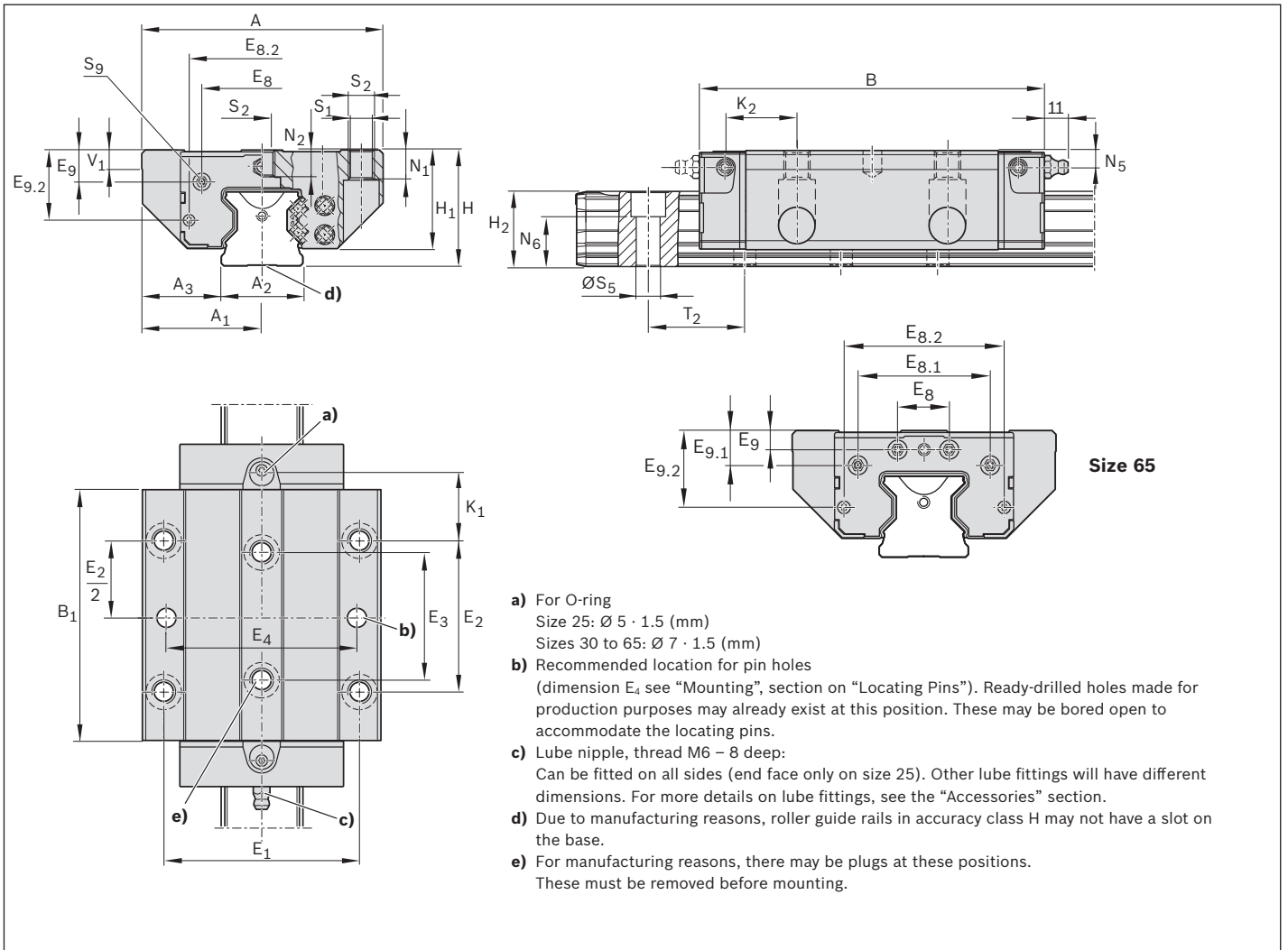
Dimensions (mm)

Size	A	A ₁	A ₂	A ₃	B	B ₁	E ₁	E ₂	E ₃	E ₄	E ₈	E _{8.1}	E _{8.2}	E ₉	E _{9.1}	E _{9.2}
25	70.00	35.00	23.00	23.50	115.00	81.50	57.00	45.00	40.00	55.00	33.40	–	40.20	8.30	–	21.40
30	90.00	45.00	28.00	31.00	130.90	95.50	72.00	52.00	44.00	70.00	43.00	–	51.00	12.00	–	25.50
35	100.00	50.00	34.00	33.00	142.00	103.60	82.00	62.00	52.00	80.00	50.30	–	60.50	13.10	–	29.10
45	120.00	60.00	45.00	37.50	179.50	134.00	100.00	80.00	60.00	98.00	62.90	–	72.00	16.70	–	36.50
55	140.00	70.00	53.00	43.50	209.65	162.10	116.00	95.00	70.00	114.00	74.20	–	81.60	18.85	–	40.75
65	170.00	85.00	63.00	53.50	255.30	194.00	142.00	110.00	82.00	140.00	35.00	93.00	106.00	9.30	26.00	55.00

Size	H	H ₁	H ₂ ²⁾	H ₂ ³⁾	K ₁	K ₂	N ₁	N ₂	N ₅	N ₆ ^{±0.5}	Ø S ₁	S ₂	Ø S ₅	S ₉ ⁴⁾	T ₂ ⁵⁾	V ₁
25	36.00	30.00	23.60	23.40	23.05	–	9.00	7.3	5.50	14.30	6.70	M8	7.00	M3-6.5 deep	30.00	7.50
30	42.00	36.60	28.00	27.80	29.25	30.36	11.80	–	6.00	16.80	8.50	M10	9.00	M3-5 deep	40.00	7.80
35	48.00	41.00	31.10	30.80	27.55	29.40	12.00	11.0	7.00	19.40	8.50	M10	9.00	M3-6 deep	40.00	8.00
45	60.00	51.00	39.10	38.80	33.70	36.60	15.00	13.5	8.00	22.40	10.40	M12	14.00	M4-9 deep	52.50	10.00
55	70.00	58.00	47.85	47.55	41.25	44.40	18.00	13.7	9.00	28.70	12.40	M14	16.00	M5-8 deep	60.00	12.00
65	90.00	76.00	58.15	57.85	54.00	57.00	23.00	21.5	9.30	36.50	14.60	M16	18.00	M4-8 deep	75.00	15.00

- 2) Dimension H₂ with cover strip
- 3) Dimension H₂ without cover strip
- 4) Thread for attachments
- 5) Dimension T₂ = hole spacing in the roller guide rail

SNS – Slimline, Normal, Standard Height

R1822 ... 2X



Dynamic characteristics

Speed: $v_{\max} = 4 \text{ m/s}$

Acceleration: $a_{\max} = 150 \text{ m/s}^2$

Recommended preload and accuracy class combinations







- ▶ For preload class C2: H and P (preferred)
- ▶ For preload class C3: P and SP

Part numbers

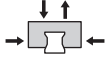
Size	Roller runner block with size	Preload class		Accuracy class				Material
		C2	C3	H	P	SP	UP	
25 ^{*)}	R1822 2	2		3	2	1	9	2X
			3		2	1	9	2X
30 ^{*)}	R1822 7	2		3	2	1	9	2X
			3		2	1	9	2X
35	R1822 3	2		3	2	1	9	2X
			3		2	1	9	2X
45	R1822 4	2		3	2	1	9	2X
			3		2	1	9	2X
55	R1822 5	2		3	2	1	9	2X
			3		2	1	9	2X
65 ^{*)}	R1822 6	2		3	2	1	9	2X
			3		2	1	9	2X

*) In preparation

Technical data

Size	Mass (kg)	Load capacities ¹⁾ (N)		Torsional load moments ¹⁾ (Nm)		Longitudinal load moments ¹⁾ (Nm)	
							
	m	C	Co	Mt	Mto	ML	ML0
25	0.54	30300	59500	390	770	300	580
30	0.95	46300	92100	780	1550	500	1000
35	1.55	61000	119400	1210	2370	760	1480
45	2.90	106600	209400	2640	5180	1650	3240
55	4.14	140400	284700	4120	8350	2610	5290
65	8.12	237200	456300	8430	16210	5260	10120

1) Determination of the dynamic load capacities and moments is based on a travel life of 100,000 m per ISO 14728 Part 1. Often only 50,000 m are actually stipulated. If this is the case, for comparison purposes: Multiply values C, M_t and M_L from the table by 1.23.

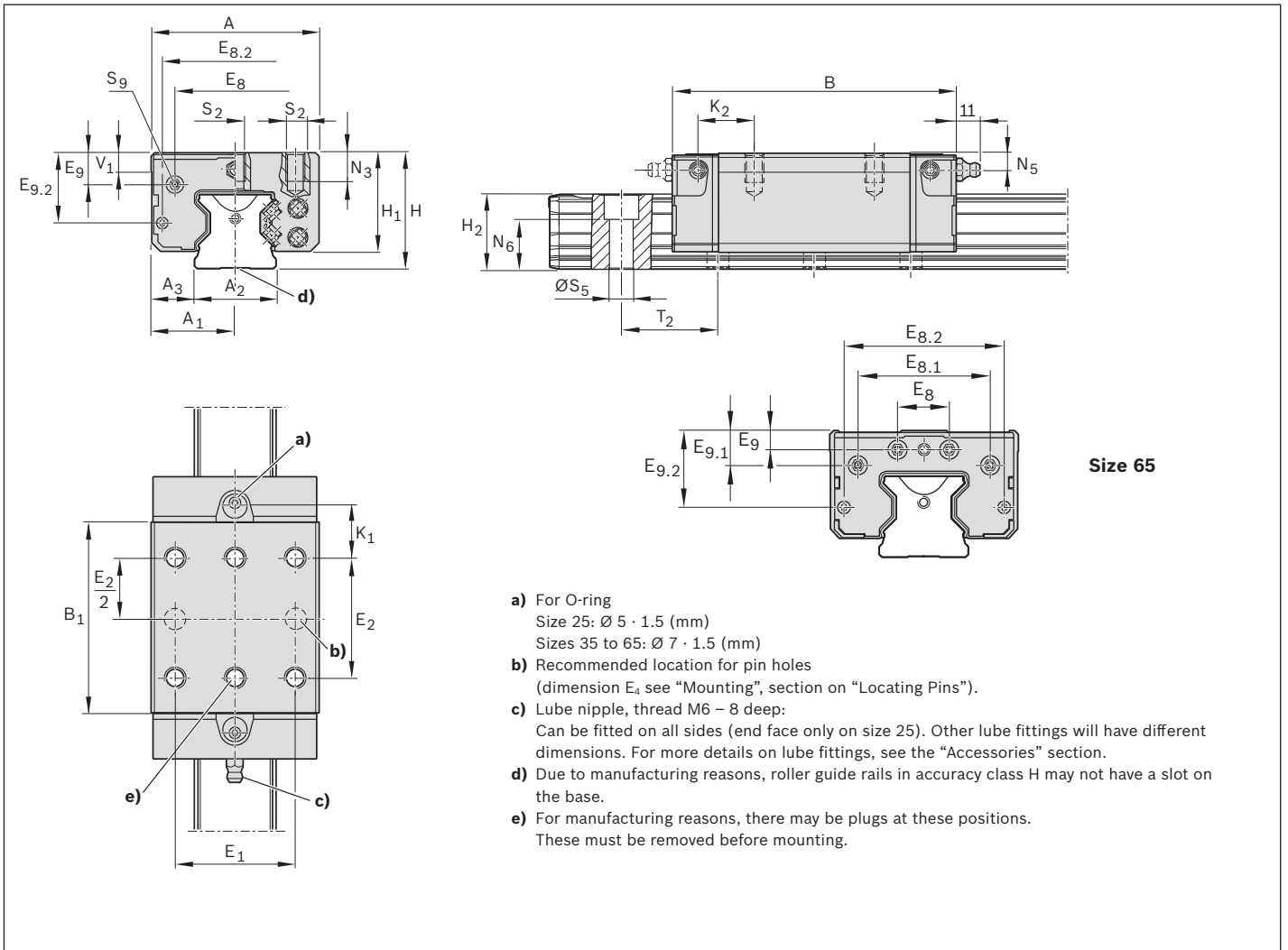
Dimensions (mm)

Size	A	A ₁	A ₂	A ₃	B	B ₁	E ₁	E ₂	E ₈	E _{8.1}	E _{8.2}	E ₉	E _{9.1}	E _{9.2}
25	48.00	24.00	23.00	12.00	97.00	63.50	35.00	35.00	33.40	–	40.20	8.30	–	21.40
30	60.00	30.00	28.00	16.00	106.40	71.00	40.00	40.00	43.00	–	51.00	12.00	–	25.50
35	70.00	35.00	34.00	18.00	118.00	79.60	50.00	50.00	50.30	–	60.50	13.10	–	29.10
45	86.00	43.00	45.00	20.50	147.00	101.50	60.00	60.00	62.90	–	72.00	16.70	–	36.50
55	100.00	50.00	53.00	23.50	170.65	123.10	75.00	75.00	74.20	–	81.60	18.85	–	40.75
65	126.00	63.00	63.00	31.50	207.30	146.00	76.00	70.00	35.00	93.00	106.00	9.30	26.00	55.00

Size	H	H ₁	H ₂ ²⁾	H ₂ ³⁾	K ₁	K ₂	N ₃	N ₅	N ₆ ^{4)0.5}	S ₂	Ø S ₅	S ₉ ⁴⁾	T ₂ ⁵⁾	V ₁
25	36.00	30.00	23.60	23.40	19.05	–	8.00	5.50	14.30	M6	7.00	M3-6.5 deep	30.00	7.50
30	42.00	36.60	28.00	27.80	23.00	24.38	12.00	6.00	16.80	M8	9.00	M3-5 deep	40.00	7.80
35	48.00	41.00	31.10	30.80	21.55	23.40	12.00	7.00	19.40	M8	9.00	M3-6 deep	40.00	8.00
45	60.00	51.00	39.10	38.80	27.45	30.35	18.00	8.00	22.40	M10	14.00	M4-9 deep	52.50	10.00
55	70.00	58.00	47.85	47.55	31.75	34.90	17.00	9.00	28.70	M12	16.00	M5-8 deep	60.00	12.00
65	90.00	76.00	58.15	57.85	50.00	53.00	21.00	9.30	36.50	M16	18.00	M4-8 deep	75.00	15.00

- 2) Dimension H₂ with cover strip
- 3) Dimension H₂ without cover strip
- 4) Thread for attachments
- 5) Dimension T₂ = hole spacing in the roller guide rail

SLS – Slimline, Long, Standard Height

R1823 ... 2X

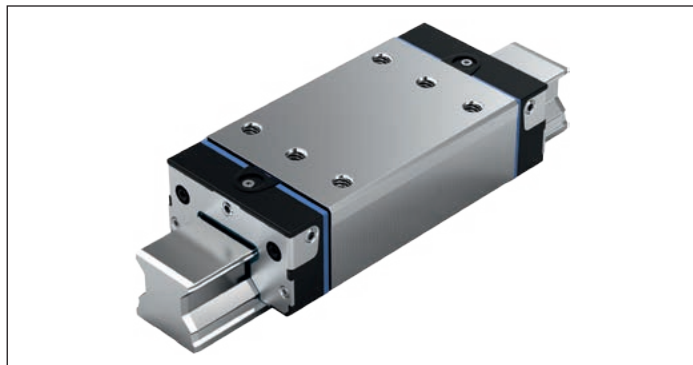

Dynamic characteristics

Speed: $v_{\max} = 4 \text{ m/s}$

Acceleration: $a_{\max} = 150 \text{ m/s}^2$

Recommended preload and accuracy class combinations

- ▶ For preload class C2: H and P (preferred)
- ▶ For preload class C3: P and SP

Part numbers

Size	Roller runner block with size	Preload class		Accuracy class				Material
		C2	C3	H	P	SP	UP	
25 ^{*)}	R1823 2	2		3	2	1	9	2X
			3		2	1	9	2X
30 ^{*)}	R1823 7	2		3	2	1	9	2X
			3		2	1	9	2X
35	R1823 3	2		3	2	1	9	2X
			3		2	1	9	2X
45	R1823 4	2		3	2	1	9	2X
			3		2	1	9	2X
55	R1823 5	2		3	2	1	9	2X
			3		2	1	9	2X
65 ^{*)}	R1823 6	2		3	2	1	9	2X
			3		2	1	9	2X

*) In preparation

Technical data

Size	Mass (kg)	Load capacities ¹⁾ (N)		Torsional load moments ¹⁾ (Nm)		Longitudinal load moments ¹⁾ (Nm)	
		C	C ₀	M _t	M _{t0}	M _L	M _{L0}
25	0.68	36800	76400	480	990	470	970
30	1.27	58400	123900	980	2090	870	1840
35	1.95	74900	155400	1490	3080	1220	2530
45	3.65	132300	276400	3270	6830	2690	5630
55	5.30	174000	374900	5100	10990	4420	9520
65	10.68	295900	606300	10510	21540	8870	18180

1) Determination of the dynamic load capacities and moments is based on a travel life of 100,000 m per ISO 14728 Part 1. Often only 50,000 m are actually stipulated. If this is the case, for comparison purposes: Multiply values C, M_t and M_L from the table by 1.23.

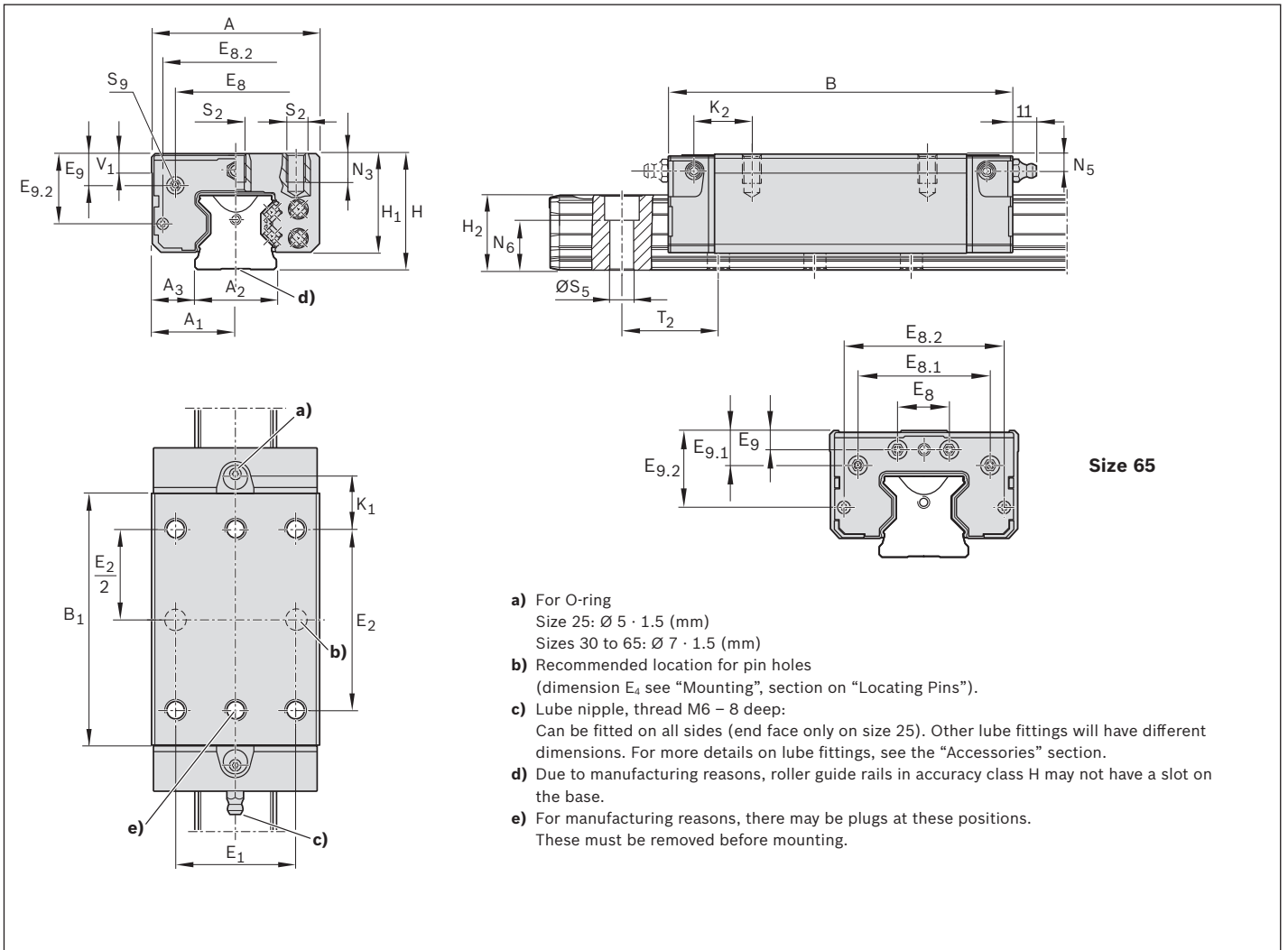
Dimensions (mm)

Size	A	A ₁	A ₂	A ₃	B	B ₁	E ₁	E ₂	E ₈	E _{8.1}	E _{8.2}	E ₉	E _{9.1}	E _{9.2}
25	48.00	24.00	23.00	12.00	115.00	81.50	35.00	50.00	33.40	–	40.20	8.30	–	21.40
30	60.00	30.00	28.00	16.00	130.90	95.50	40.00	60.00	43.00	–	51.00	12.00	–	25.50
35	70.00	35.00	34.00	18.00	142.00	103.60	50.00	72.00	50.30	–	60.50	13.10	–	29.10
45	86.00	43.00	45.00	20.50	179.50	134.00	60.00	80.00	62.90	–	72.00	16.70	–	36.50
55	100.00	50.00	53.00	23.50	209.65	162.10	75.00	95.00	74.20	–	81.60	18.85	–	40.75
65	126.00	63.00	63.00	31.50	255.30	194.00	76.00	120.00	35.00	93.00	106.00	9.30	26.00	55.00

Size	H	H ₁	H ₂ ²⁾	H ₂ ³⁾	K ₁	K ₂	N ₃	N ₅	N ₆ ^{4)0.5}	S ₂	Ø S ₅	S ₉ ⁴⁾	T ₂ ⁵⁾	V ₁
25	36.00	30.00	23.60	23.40	20.55	–	8.00	5.50	14.30	M6	7.00	M3-6.5 deep	30.00	7.50
30	42.00	36.60	28.00	27.80	25.25	26.63	12.00	6.00	16.80	M8	9.00	M3-5 deep	40.00	7.80
35	48.00	41.00	31.10	30.80	22.55	24.40	12.00	7.00	19.40	M8	9.00	M3-6 deep	40.00	8.00
45	60.00	51.00	39.10	38.80	33.70	36.60	18.00	8.00	22.40	M10	14.00	M4-9 deep	52.50	10.00
55	70.00	58.00	47.85	47.55	41.25	44.40	17.00	9.00	28.70	M12	16.00	M5-8 deep	60.00	12.00
65	90.00	76.00	58.15	57.85	49.00	52.00	21.00	9.30	36.50	M16	18.00	M4-8 deep	75.00	15.00

- 2) Dimension H₂ with cover strip
- 3) Dimension H₂ without cover strip
- 4) Thread for attachments
- 5) Dimension T₂ = hole spacing in the roller guide rail

SNH – Slimline, Normal, High

R1821 ... 2X



Dynamic characteristics

Speed: $v_{\max} = 4 \text{ m/s}$

Acceleration: $a_{\max} = 150 \text{ m/s}^2$

Recommended preload and accuracy class combinations



- ▶ For preload class C2: H and P (preferred)
- ▶ For preload class C3: P and SP

Part numbers

Size	Roller runner block with size	Preload class		Accuracy class				Material
		C2	C3	H	P	SP	UP	
25 ^{*)}	R1821 2	2		3	2	1	9	2X
			3		2	1	9	2X
30 ^{*)}	R1821 7	2		3	2	1	9	2X
			3		2	1	9	2X
35	R1821 3	2		3	2	1	9	2X
			3		2	1	9	2X
45	R1821 4	2		3	2	1	9	2X
			3		2	1	9	2X
55	R1821 5	2		3	2	1	9	2X
			3		2	1	9	2X

^{*)} In preparation

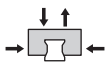
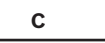
Technical data

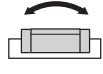
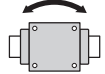
Size	Mass (kg)	Load capacities ¹⁾ (N)		Torsional load moments ¹⁾ (Nm)		Longitudinal load moments ¹⁾ (Nm)	
							
	m	C	C ₀	M _t	M _{t0}	M _L	M _{L0}
25	0.63	30300	59500	390	770	300	580
30	1.04	46300	92100	780	1550	500	1000
35	1.85	61000	119400	1210	2370	760	1480
45	3.35	106600	209400	2640	5180	1650	3240
55	5.04	140400	284700	4120	8350	2610	5290

¹⁾ Determination of the dynamic load capacities and moments is based on a travel life of 100,000 m per ISO 14728 Part 1. Often only 50,000 m are actually stipulated. If this is the case, for comparison purposes: Multiply values C, M_t and M_L from the table by 1.23.

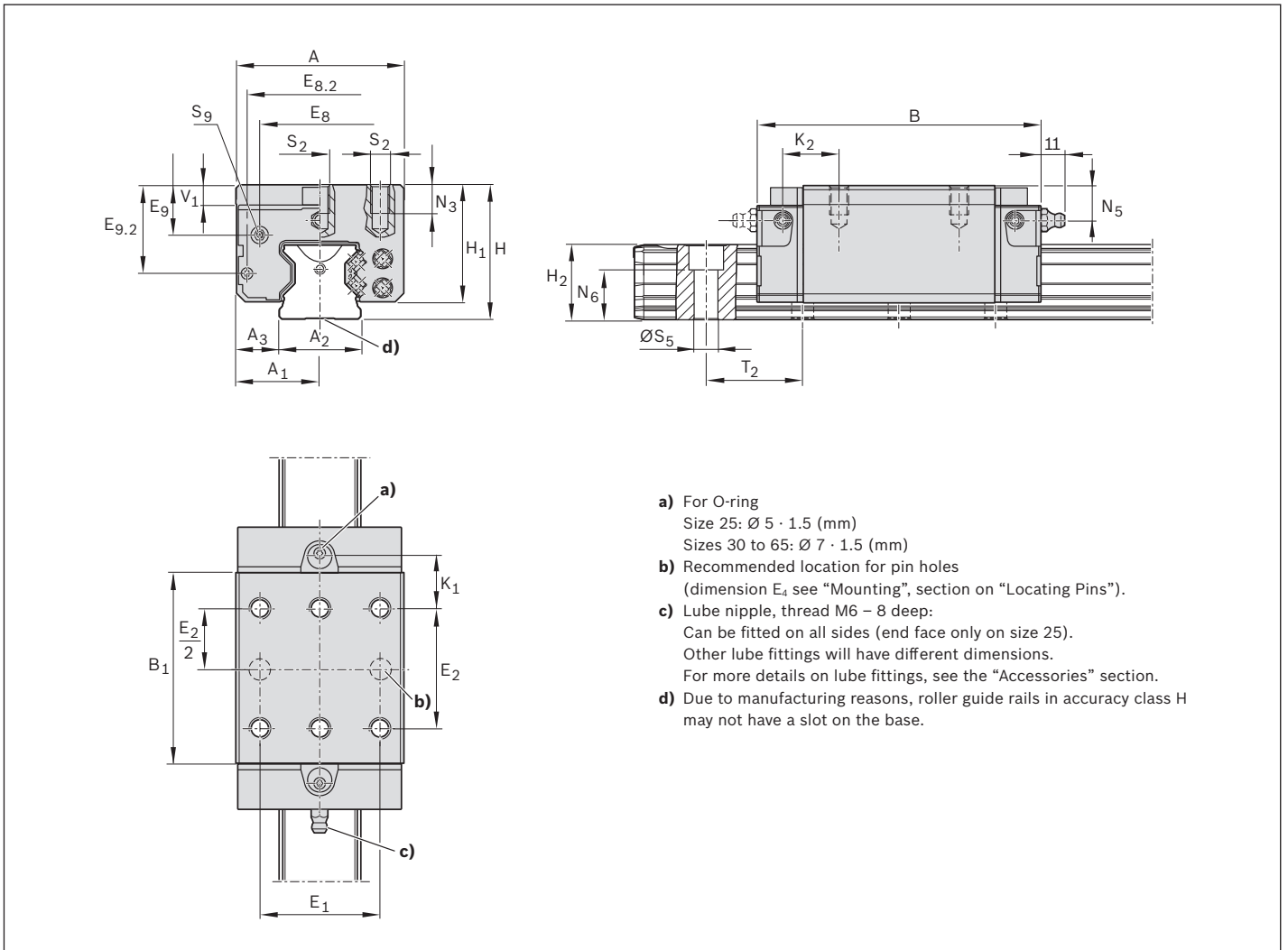
Dimensions (mm)

Size	A	A ₁	A ₂	A ₃	B	B ₁	E ₁	E ₂	E ₈	E _{8.2}	E ₉	E _{9.2}
25	48.00	24.00	23.00	12.00	97.00	63.50	35.00	35.00	33.40	40.20	12.30	25.40
30	60.00	30.00	28.00	16.00	106.40	71.00	40.00	40.00	43.00	51.00	15.00	28.50
35	70.00	35.00	34.00	18.00	118.00	79.60	50.00	50.00	50.30	60.50	20.10	36.10
45	86.00	43.00	45.00	20.50	147.00	101.50	60.00	60.00	62.90	72.00	26.70	46.50
55	100.00	50.00	53.00	23.50	170.65	123.10	75.00	75.00	74.20	81.60	28.85	50.75

Size	H	H ₁	H ₂ ²⁾	H ₂ ³⁾	K ₁	K ₂	N ₃	N ₅	N ₆ ^{±0.5}	S ₂	S ₅	S ₉ ⁴⁾	T ₂ ⁵⁾	V ₁
25	40.00	34.00	23.60	23.40	19.05	–	8.00	–	14.30	M6	Ø 7.00	M3-6.5 deep	30.00	7.50
30	45.00	39.60	28.00	27.80	23.00	24.38	12.00	9.00	16.80	M8	Ø 9.00	M3-5 deep	40.00	7.80
35	55.00	48.00	31.10	30.80	21.55	23.40	13.00	14.00	19.40	M8	Ø 9.00	M3-6 deep	40.00	8.00
45	70.00	61.00	39.10	38.80	27.45	30.35	18.00	18.00	22.40	M10	Ø 14.00	M4-9 deep	52.50	10.00
55	80.00	68.00	47.85	47.55	31.75	34.90	19.00	19.00	28.70	M12	Ø 16.00	M5-8 deep	60.00	12.00

2) Dimension H₂ with cover strip

3) Dimension H₂ without cover strip

4) Thread for attachments

5) Dimension T₂ = hole spacing in the roller guide rail

SLH – Slimline, Long, High

R1824 ... 2X

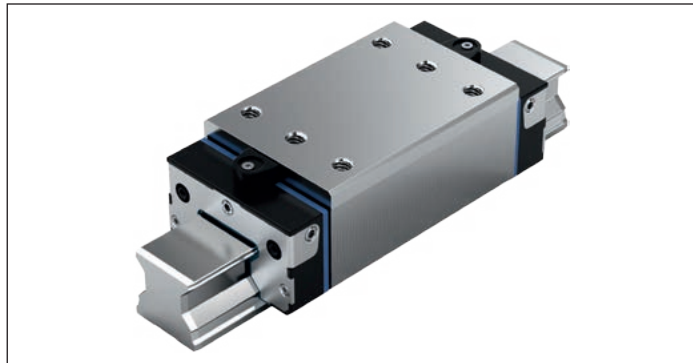

Dynamic characteristics

Speed: $v_{\max} = 4 \text{ m/s}$

Acceleration: $a_{\max} = 150 \text{ m/s}^2$

Recommended preload and accuracy class combinations



- ▶ For preload class C2: H and P (preferred)
- ▶ For preload class C3: P and SP

Part numbers

Size	Roller runner block with size	Preload class		Accuracy class				Material
		C2	C3	H	P	SP	UP	
25 ^{*)}	R1824 2	2		3	2	1	9	2X
			3		2	1	9	2X
30 ^{*)}	R1824 7	2		3	2	1	9	2X
			3		2	1	9	2X
35	R1824 3	2		3	2	1	9	2X
			3		2	1	9	2X
45	R1824 4	2		3	2	1	9	2X
			3		2	1	9	2X
55	R1824 5	2		3	2	1	9	2X
			3		2	1	9	2X

^{*)} In preparation

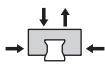
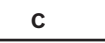
Technical data

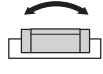
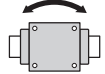
Size	Mass (kg)	Load capacities ¹⁾ (N)		Torsional load moments ¹⁾ (Nm)		Longitudinal load moments ¹⁾ (Nm)	
							
	m	C	C ₀	M _t	M _{t0}	M _L	M _{L0}
25	0.80	36800	76400	480	990	470	970
30	1.37	58400	123900	980	2090	870	1840
35	2.35	74900	155400	1490	3080	1220	2530
45	4.45	132300	276400	3270	6830	2690	5630
55	6.55	174000	374900	5100	10990	4420	9520

¹⁾ Determination of the dynamic load capacities and moments is based on a travel life of 100,000 m per ISO 14728 Part 1. Often only 50,000 m are actually stipulated. If this is the case, for comparison purposes: Multiply values C, M_t and M_L from the table by 1.23.

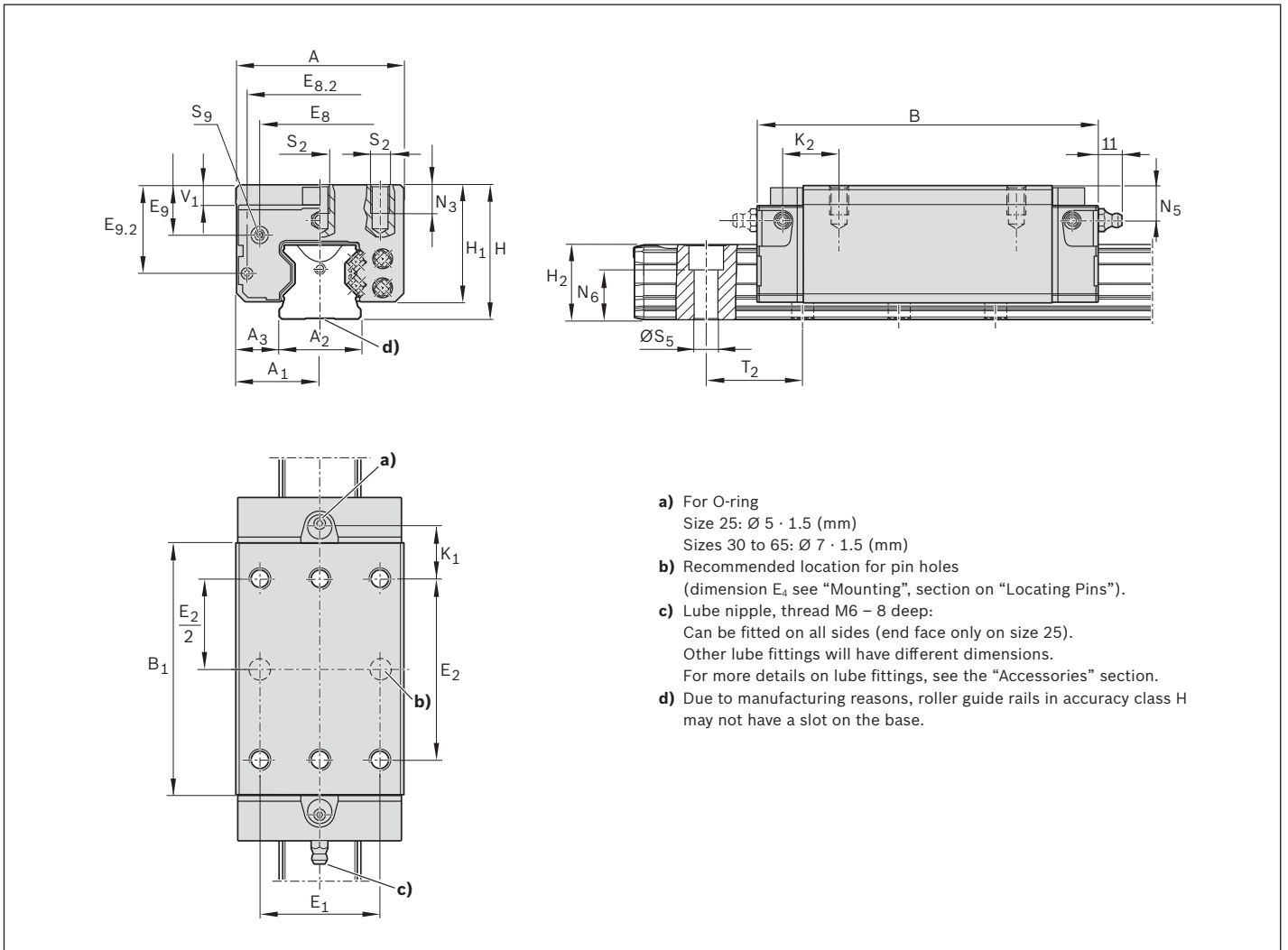
Dimensions (mm)

Size	A	A ₁	A ₂	A ₃	B	B ₁	E ₁	E ₂	E ₈	E _{8.2}	E ₉	E _{9.2}
25	48.00	24.00	23.00	12.00	115.00	81.50	35.00	50.00	33.40	40.20	12.30	25.40
30	60.00	30.00	28.00	16.00	130.90	95.50	40.00	60.00	43.00	51.00	15.00	28.50
35	70.00	35.00	34.00	18.00	142.00	103.60	50.00	72.00	50.30	60.50	20.10	36.10
45	86.00	43.00	45.00	20.50	179.50	134.00	60.00	80.00	62.90	72.00	26.70	46.50
55	100.00	50.00	53.00	23.50	209.65	162.10	75.00	95.00	74.20	81.60	28.85	50.75

Size	H	H ₁	H ₂ ²⁾	H ₂ ³⁾	K ₁	K ₂	N ₃	N ₅	N ₆ ^{20.5}	S ₂	S ₅	S ₉ ⁴⁾	T ₂ ⁵⁾	V ₁
25	40.00	34.00	23.60	23.40	20.55	–	8.00	9.50	14.30	M6	$\varnothing 7.00$	M3-6.5 deep	30.00	7.50
30	45.00	39.60	28.00	27.80	25.25	26.63	12.00	9.00	16.80	M8	$\varnothing 9.00$	M3-5 deep	40.00	7.80
35	55.00	48.00	31.10	30.80	22.55	24.40	13.00	14.00	19.40	M8	$\varnothing 9.00$	M3-6 deep	40.00	8.00
45	70.00	61.00	39.10	38.80	33.70	36.60	18.00	18.00	22.40	M10	$\varnothing 14.00$	M4-9 deep	52.50	10.00
55	80.00	68.00	47.85	47.55	41.25	44.40	19.00	19.00	28.70	M12	$\varnothing 16.00$	M5-8 deep	60.00	12.00

2) Dimension H₂ with cover strip

3) Dimension H₂ without cover strip

4) Thread for attachments

5) Dimension T₂ = hole spacing in the roller guide rail

Product Description

Characteristic features

- ▶ Roller guide rails with hardened raceways and ground
- ▶ Maximum rigidity under load from all directions
- ▶ Very high torque capacity

Roller guide rail SNS with proven cover strip for covering mounting holes

- ▶ A single cover for all holes – saves time and money
- ▶ Stainless spring steel to EN 10088
- ▶ Easy, secure mounting
- ▶ Clip on and fasten



Overview of Design Types and Models



SNS with cover strip and strip clamps



SNS with cover strip and protective end caps



SNS with cover strip and screw/washer



SNS for cover strip



SNS with plastic mounting hole plugs

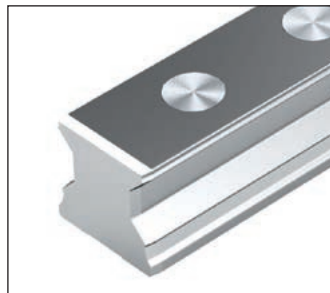

SNS with steel mounting hole plugs

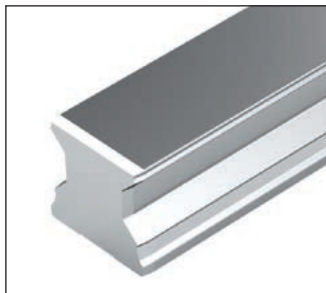

SNS for mounting from below

Definition of roller guide rail design types

Criterion	Description	Code (example)		
		S	N	S
Width	Slimline	S		
	Wide (B)	B		
Length	Normal		N	
Height	Standard height			S
	Without slot (O)			O

Ordering Roller Guide Rails in Recommended Lengths

Recommended rail lengths are delivered with priority.

From the desired length to the recommended length

$$L = \left(\frac{L_w}{T_2} \right) \cdot T_2 - 4$$

Round up the quotient L_w/T_2 to the next whole number!

Calculation example

$$L = \frac{1660 \text{ mm}}{40 \text{ mm}} \cdot 40 \text{ mm} - 4 \text{ mm}$$

$$L = 42 \cdot 40 \text{ mm} - 4 \text{ mm}$$

$$L = 1676 \text{ mm}$$

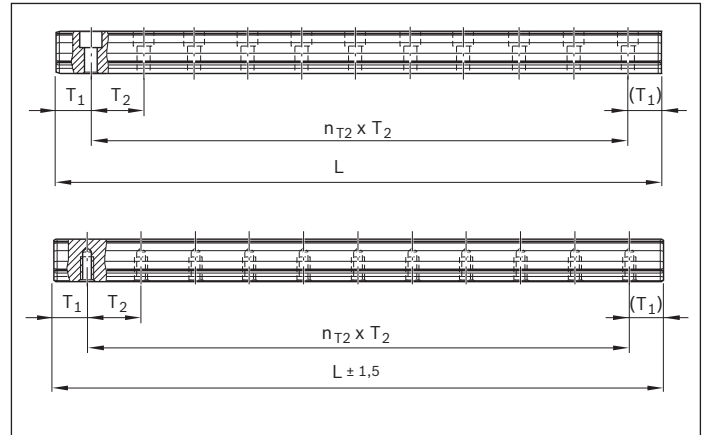

Basis: number of holes

$$L = n_B \cdot T_2 - 4$$

L = recommended rail length (mm)
 L_w = desired rail length (mm)
 T_2 = hole spacing (mm)
 T_{1S} = preferred dimension (mm)
 n_B = number of holes
 n_{T_2} = number of spaces

Basis: number of spaces

$$L = n_{T_2} \cdot T_2 + 2 \cdot T_{1S}$$

If the preferred dimension T_{1S} cannot be used:

- ▶ Select an end space T_1 between T_{1S} and $T_{1 \min}$.
- ▶ Do not go below the minimum spacing $T_{1 \min}$!

SNS/SNO with Cover Strip and Strip Clamps

R1805 .3. .. / R1805 .B. ..



For mounting from above, with cover strip made of corrosion-resistant spring steel per EN 10088 and strip clamps made of aluminum (without threaded mounting holes on end face)

Notes

- ▶ Secure the cover strip!
- ▶ Strip clamps are included in the supply scope.
- ▶ Follow the mounting instructions!
- ▶ Send for the publications “Mounting Instructions for Roller Rail Systems” and “Mounting Instructions for the Cover Strip.”
- ▶ Composite roller guide rails also available.

Roller guide rails R1805 .B. .. with flat underside for mounting on components made of cast mineral materials. In size 35-65 and accuracy class H, P, SP, GP available, UP on request.

Part numbers

Size	Roller guide rail with size	Accuracy class					Number of sections		Hole spacing T_2 (mm)	Recommended rail lengths $L = n_B \cdot T_2 - 4 \text{ mm}$ Maximum number of bores n_B	
		H	P	SP	GP	UP	One-piece	Composite			
25	R1805 23	3	2	1	8	9	31,	3, ...	30.0		133
30 ^{*)}	R1805 73	3	2	1	8	9	31,	3, ...	40.0		100
35	R1805 33	3	2	1	8	9	61,	6, ...	40.0		100
45	R1805 43	3	2	1	8	9	61,	6, ...	52.5		76
55	R1805 53	3	2	1	8	9	61,	6, ...	60.0		66
65	R1805 63	3	2	1	8	9	61,	6, ...	75.0		53

*) In preparation

Ordering example 1 (up to L_{\max})

Options:

- ▶ Roller guide rail SNS
- ▶ Size 35
- ▶ Accuracy class P
- ▶ One-piece
- ▶ Rail length
L = 1676 mm

Part number:

R1805 332 61, 1676 mm

Ordering example 2 (over L_{\max})

Options:

- ▶ Roller guide rail SNS
- ▶ Size 35
- ▶ Accuracy class P
- ▶ **Composite (2 pieces)**
- ▶ Rail length
L = 5036 mm

Part number:

R1805 332 62, 5036 mm

Ordering example 3 (up to L_{\max} with flat underside)

Options:

- ▶ Roller guide rail SNO
- ▶ Size 35
- ▶ Accuracy class P
- ▶ One-piece
- ▶ Rail length
L = 1676 mm

Part number:

R1805 3B2 61, 1676 mm

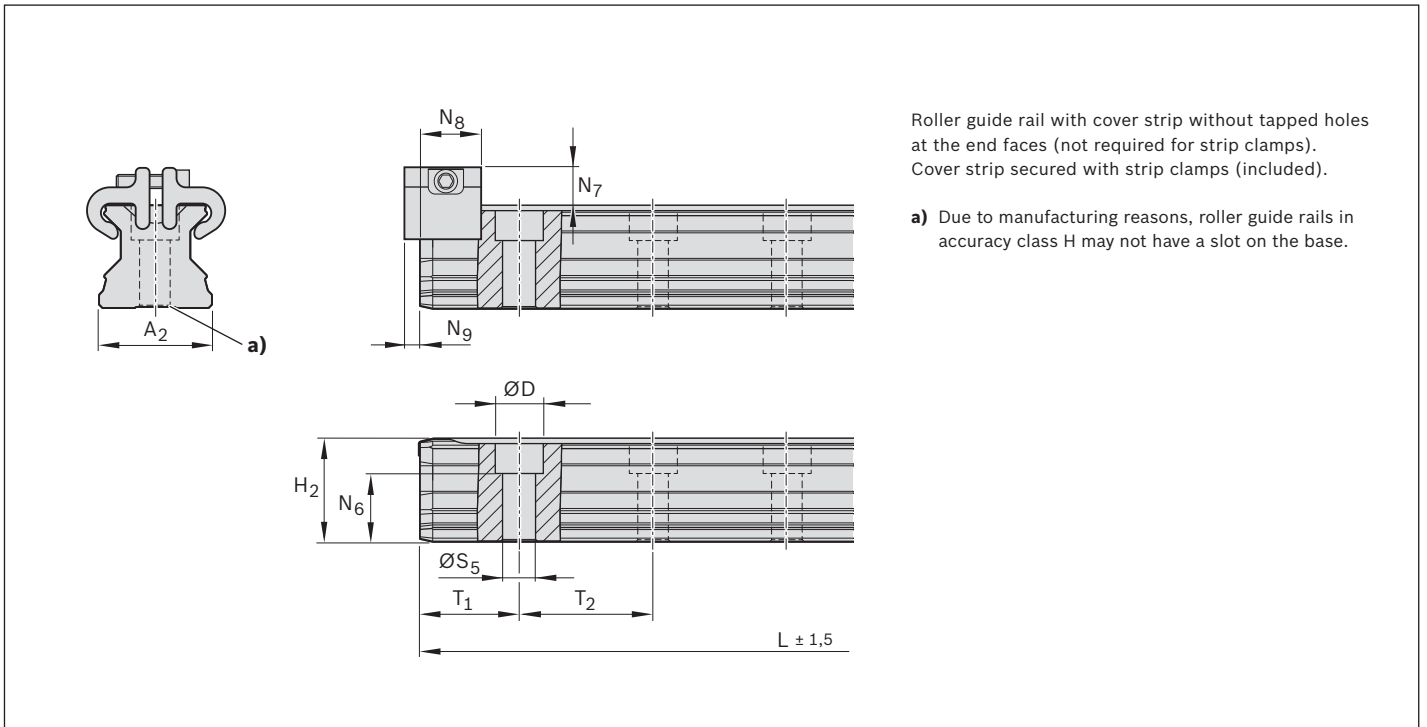
Dimensions (mm)

Size	A ₂	D	H ₂ ¹⁾	L _{max} ²⁾	N ₆ ^{20.5}	N ₇ ³⁾	N ₈	N ₉	S ₅	T _{1 min}	T _{1 s} ⁴⁾	T ₂	Mass (kg/m)
25	23	11	23.60	3986	14.3	8.2	13	2.0	7	13	13.00	30.0	3.1
30 ^{*)}	28	15	28.00	3996	16.8	8.7	13	2.0	9	16	18.00	40.0	4.3
35	34	15	31.10	3996	19.4	11.7	16	2.2	9	16	18.00	40.0	6.3
45	45	20	39.10	3986	22.4	12.5	18	2.2	14	18	24.25	52.5	10.3
55	53	24	47.85	3956	28.7	14.0	17	3.2	16	20	28.00	60.0	13.1
65	63	26	58.15	3971	36.5	15.0	17	3.2	18	21	35.50	75.0	17.4

*) In preparation

- 1) Dimension H₂ with cover strip
Up to size 30 with cover strip 0.2 mm
From size 35 with cover strip 0.3 mm
- 2) Sizes 30 and 35: one-piece length up to 5996 mm also available
Size 45: one-piece length up to 5981 mm also available
Size 55: one-piece length up to 5936 mm also available
Size 65: one-piece length up to 5921 mm also available
- 3) Dimension N₇ with cover strip
- 4) Preferred dimension T_{1 s} with tolerances ± 0.75

SNS/SNO with Cover Strip and Protective End Caps

R1805 .6. .. / R1805 .D. ..



For mounting from above, with cover strip made of corrosion-resistant spring steel per EN 10088 and strip screw-down plastic protective end caps (with threaded mounting holes on end face)

Notes

- ▶ As an alternative, the cover strip can be secured with screws and washers.
- ▶ Protective caps with screws and washers included in scope of supply.
- ▶ Follow the mounting instructions!
- ▶ Send for the publications “Mounting Instructions for Roller Rail Systems” and “Mounting Instructions for the Cover Strip.”
- ▶ Composite roller guide rails also available.

Roller guide rails R1805 .D. .. with flat underside for mounting on components made of cast mineral materials. In size 35-65 and accuracy class H, P, SP, GP available, UP on request.

Part numbers

Size	Roller guide rail with size	Accuracy class					Number of sections		Hole spacing T_2 (mm)	Recommended rail lengths	
		H	P	SP	GP	UP	One-piece	Composite		$L = n_B \cdot T_2 - 4 \text{ mm}$	Maximum number of bores n_B
25	R1805 26	3	2	1	8	9	31, ...	3, ...	30.0		133
30 ^{*)}	R1805 76	3	2	1	8	9	31, ...	3, ...	40.0		100
35	R1805 36	3	2	1	8	9	61, ...	6, ...	40.0		100
45	R1805 46	3	2	1	8	9	61, ...	6, ...	52.5		76
55	R1805 56	3	2	1	8	9	61, ...	6, ...	60.0		66
65	R1805 66	3	2	1	8	9	61, ...	6, ...	75.0		53

*) In preparation

Ordering example 1 (up to L_{max})

Options:

- ▶ Roller guide rail SNS
- ▶ Size 35
- ▶ Accuracy class P
- ▶ One-piece
- ▶ Rail length
L = 1676 mm

Part number:

R1805 362 61, 1676 mm

Ordering example 2 (over L_{max})

Options:

- ▶ Roller guide rail SNS
- ▶ Size 35
- ▶ Accuracy class P
- ▶ **Composite (2 pieces)**
- ▶ Rail length
L = 5036 mm

Part number:

R1805 362 62, 5036 mm

Ordering example 3 (up to L_{max} with flat underside)

Options:

- ▶ Roller guide rail SNO
- ▶ Size 35
- ▶ Accuracy class P
- ▶ One-piece
- ▶ Rail length
L = 1676 mm

Part number:

R1805 3D2 61, 1676 mm

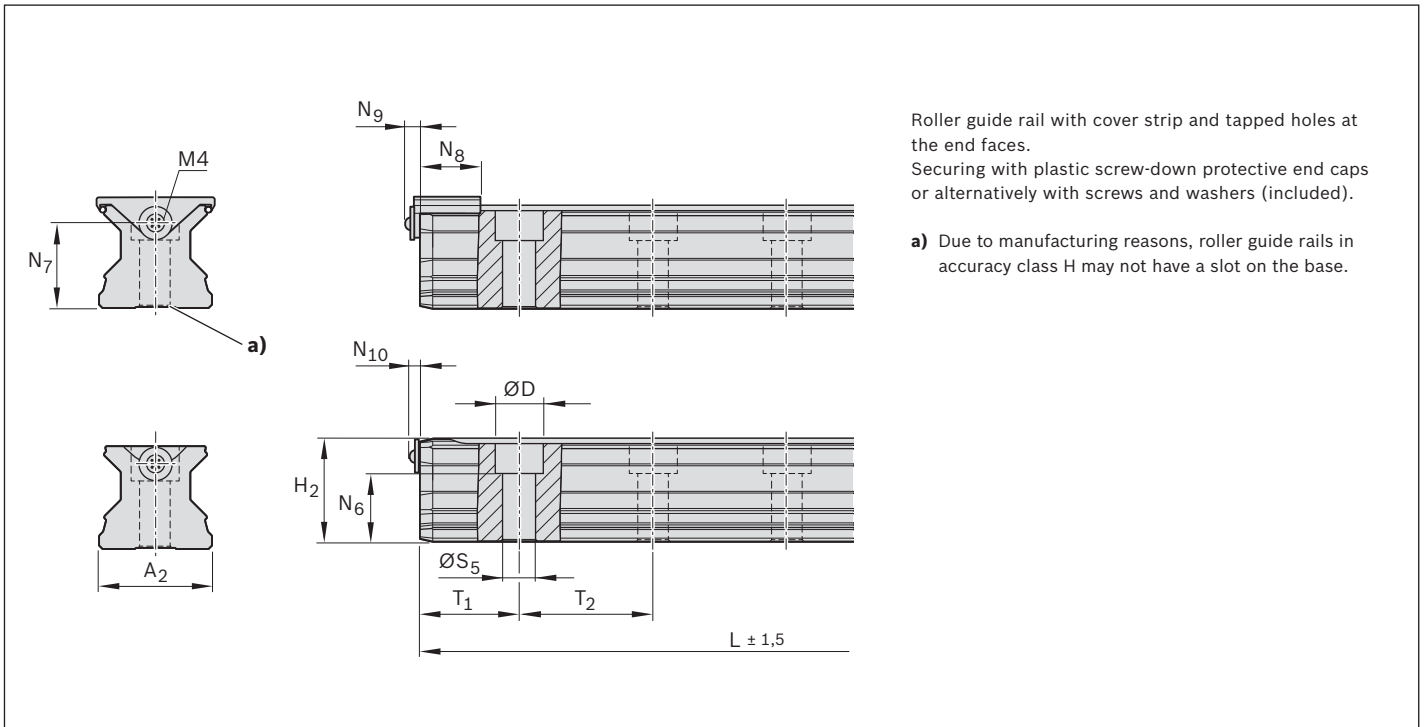

Roller guide rail with cover strip and tapped holes at the end faces.
Securing with plastic screw-down protective end caps or alternatively with screws and washers (included).

a) Due to manufacturing reasons, roller guide rails in accuracy class H may not have a slot on the base.

Dimensions (mm)

Size	A ₂	D	H ₂ ¹⁾	L _{max} ²⁾	N ₆ ^{±0,5}	N ₇	N ₈	N ₉	N ₁₀	S ₅	T _{1 min}	T _{1 s} ³⁾	T ₂	Mass (kg/m)
25	23	11	23.60	3986	14.3	15	15.2	6.5	4.10	7	13	13.00	30.0	3.1
30 ^{*)}	28	15	28.00	3996	16.8	18	15.2	7.0	4.10	9	16	18.00	40.0	4.3
35	34	15	31.10	3996	19.4	22	18	7.0	4.10	9	16	18.00	40.0	6.3
45	45	20	39.10	3986	22.4	30	20	7.0	4.10	14	18	24.25	52.5	10.3
55	53	24	47.85	3956	28.7	30	20	7.0	4.35	16	20	28.00	60.0	13.1
65	63	26	58.15	3971	36.5	40	20	7.0	4.35	18	21	35.50	75.0	17.4

*) In preparation

- 1) Dimension H₂ with cover strip
Up to size 30 with cover strip 0.2 mm
From size 35 with cover strip 0.3 mm
- 2) Sizes 30 and 35: one-piece length up to 5996 mm also available
Size 45: one-piece length up to 5981 mm also available
Size 55: one-piece length up to 5936 mm also available
Size 65: one-piece length up to 5921 mm also available
- 3) Preferred dimension T_{1s} with tolerances ± 0.75

SNS/SNO for Cover Strip

R1805 .2. 3./R1805 .A. 3.



For mounting from above, for cover strip (not included)

Notes

- ▶ Secure the cover strip!
- ▶ The cover strip and strip clamps or protective caps must be ordered separately. For part numbers and dimensions see “Accessories”.
- ▶ Follow the mounting instructions!
- ▶ Send for the publications “Mounting Instructions for Roller Rail Systems” and “Mounting Instructions for the Cover Strip.”
- ▶ Composite roller guide rails also available.

Roller guide rails R1805 .A. 3. with flat underside for mounting on components made of cast mineral materials. In size 35-65 and accuracy class H, P, SP, GP available, UP on request.

Part numbers

Size	Roller guide rail with size	Accuracy class					Number of sections		Hole spacing T_2 (mm)	Recommended rail lengths $L = n_B \cdot T_2 - 4 \text{ mm}$ Maximum number of bores n_B	
		H	P	SP	GP	UP	One-piece	Composite			
25	R1805 22	3	2	1	8	9	31, ...	3, ...	30.0		133
30 ^{*)}	R1805 72	3	2	1	8	9	31, ...	3, ...	40.0		100
35	R1805 32	3	2	1	8	9	31, ...	3, ...	40.0		100
45	R1805 42	3	2	1	8	9	31, ...	3, ...	52.5		76
55	R1805 52	3	2	1	8	9	31, ...	3, ...	60.0		66
65	R1805 62	3	2	1	8	9	31, ...	3, ...	75.0		53

*) In preparation

Ordering example 1 (up to L_{\max})

Options:

- ▶ Roller guide rail SNS
- ▶ Size 35
- ▶ Accuracy class P
- ▶ One-piece
- ▶ Rail length
L = 1676 mm

Part number:

R1805 322 31, 1676 mm

Ordering example 2 (over L_{\max})

Options:

- ▶ Roller guide rail SNS
- ▶ Size 35
- ▶ Accuracy class P
- ▶ **Composite (2 pieces)**
- ▶ Rail length
L = 5036 mm

Part number:

R1805 322 32, 5036 mm

Ordering example 3 (up to L_{\max} with flat underside)

Options:

- ▶ Roller guide rail SNO
- ▶ Size 35
- ▶ Accuracy class P
- ▶ One-piece
- ▶ Rail length
L = 1676 mm

Part number:

R1805 3A2 31, 1676 mm

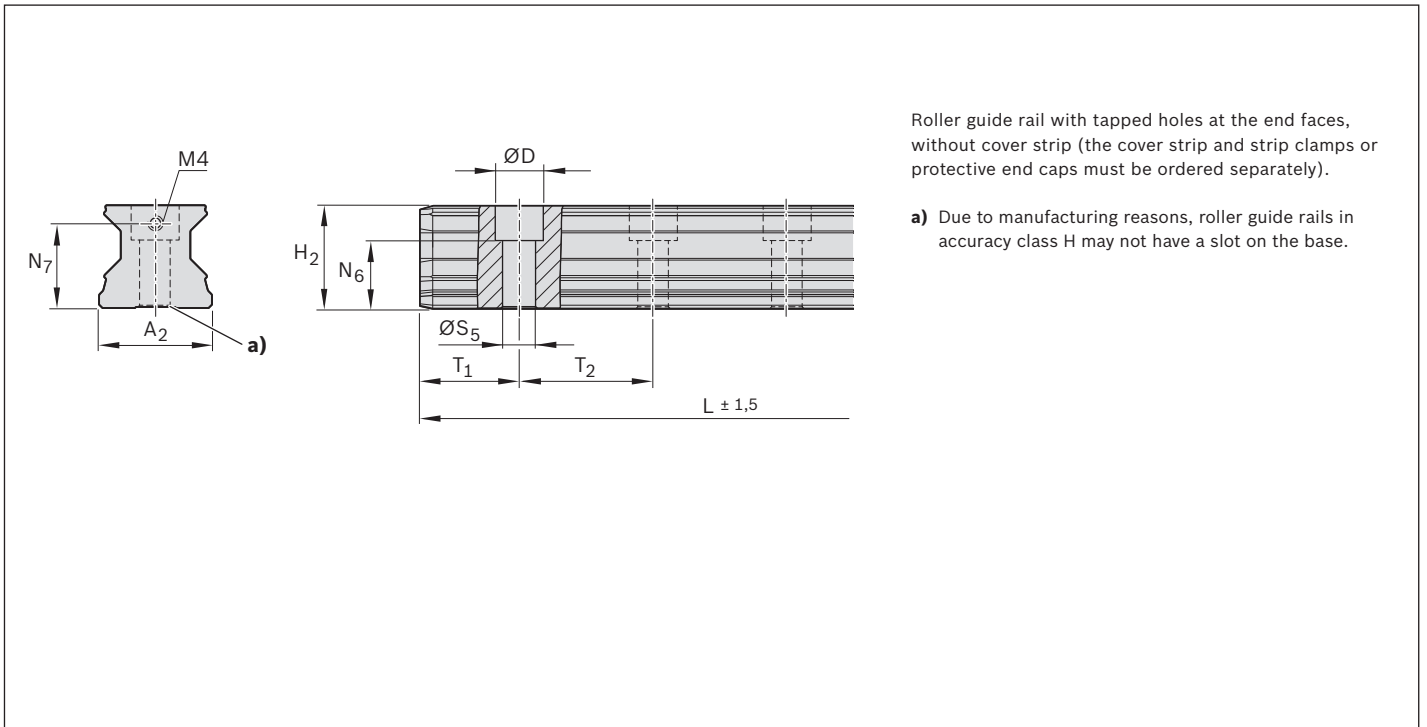
Dimensions (mm)

Size	A ₂	D	H ₂	L _{max} ¹⁾	N ₆ ^{±0.5}	N ₇	S ₅	T _{1 min}	T _{1 s} ²⁾	T ₂	Mass (kg/m)
25	23	11	23.40	3986	14.3	15	7	13	13.00	30.0	3.1
30 ^{*)}	28	15	27.80	3996	16.8	18	9	16	18.00	40.0	4.3
35	34	15	30.80	3996	19.4	22	9	16	18.00	40.0	6.3
45	45	20	38.80	3986	22.4	30	14	18	24.25	52.5	10.3
55	53	24	47.55	3956	28.7	30	16	20	28.00	60.0	13.1
65	63	26	57.85	3971	36.5	40	18	21	35.50	75.0	17.4

^{*)} In preparation

- 1) Sizes 30 and 35: one-piece length up to 5996 mm also available
 Size 45: one-piece length up to 5981 mm also available
 Size 55: one-piece length up to 5936 mm also available
 Size 65: one-piece length up to 5921 mm also available
- 2) Preferred dimension T_{1s} with tolerances ± 0.75

SNS/SNO with Plastic Mounting Hole Plugs

R1805 .5. 3./R1805 .C. 3.



For mounting from above, with plastic mounting hole plugs

Notes

- ▶ Plastic mounting hole plugs included in scope of supply.
- ▶ Follow the mounting instructions!
- ▶ Send for the publication “Mounting Instructions for Roller Rail Systems.”
- ▶ Composite roller guide rails also available.

Roller guide rails R1805 .C. 3. with flat underside for mounting on components made of cast mineral materials. In size 35-65 and accuracy class H, P, SP, GP available, UP on request.

Part numbers

Size	Roller guide rail with size	Accuracy class					Number of sections		Hole spacing T_2 (mm)	Recommended rail lengths	
		H	P	SP	GP	UP	One-piece	Composite		$L = n_B \cdot T_2 - 4 \text{ mm}$	Maximum number of bores n_B
25	R1805 25	3	2	1	8	9	31, ...	3, ...	30.0		133
30 ^{*)}	R1805 75	3	2	1	8	9	31, ...	3, ...	40.0		100
35	R1805 35	3	2	1	8	9	31, ...	3, ...	40.0		100
45	R1805 45	3	2	1	8	9	31, ...	3, ...	52.5		76
55	R1805 55	3	2	1	8	9	31, ...	3, ...	60.0		66
65	R1805 65	3	2	1	8	9	31, ...	3, ...	75.0		53

*) In preparation

Ordering example 1 (up to L_{\max})

Options:

- ▶ Roller guide rail SNS
- ▶ Size 35
- ▶ Accuracy class P
- ▶ One-piece
- ▶ Rail length

$L = 1676 \text{ mm}$

Part number:

R1805 352 31, 1676 mm

Ordering example 2 (over L_{\max})

Options:

- ▶ Roller guide rail SNS
- ▶ Size 35
- ▶ Accuracy class P
- ▶ **Composite (2 pieces)**
- ▶ Rail length

$L = 5036 \text{ mm}$

Part number:

R1805 352 32, 5036 mm

Ordering example 3 (up to L_{\max} with flat underside)

Options:

- ▶ Roller guide rail SNO
- ▶ Size 35
- ▶ Accuracy class P
- ▶ One-piece
- ▶ Rail length

$L = 1676 \text{ mm}$

Part number:

R1805 3C2 31, 1676 mm

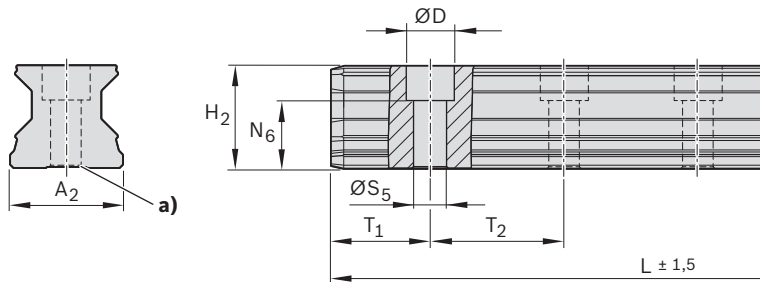

Plastic mounting hole plugs are supplied with the roller guide rails and are also available as accessories. For details on how to mount the plastic plugs, see "Mounting Instructions for Roller Rail Systems."

a) Due to manufacturing reasons, roller guide rails in accuracy class H may not have a slot on the base.

Dimensions (mm)

Size	A_2	D	H_2	$L_{\max}^{1)}$	$N_6^{\pm 0,5}$	S_5	$T_{1 \min}$	$T_{1 S}^{2)}$	T_2	Mass (kg/m)
25	23	11	23.40	3986	14.3	7	10	13.00	30.0	3.1
30 ^{*)}	28	15	27.80	3996	16.8	9	12	18.00	40.0	4.3
35	34	15	30.80	3996	19.4	9	12	18.00	40.0	6.3
45	45	20	38.80	3986	22.4	14	16	24.25	52.5	10.3
55	53	24	47.55	3956	28.7	16	18	28.00	60.0	13.1
65	63	26	57.85	3971	36.5	18	20	35.50	75.0	17.4

*) In preparation

- 1) Sizes 30 and 35: one-piece length up to 5996 mm also available
 Size 45: one-piece length up to 5981 mm also available
 Size 55: one-piece length up to 5936 mm also available
 Sizes 65 and 65/100: one-piece length up to 5921 mm also available
- 2) Preferred dimension $T_{1 S}$ with tolerances ± 0.75

SNS/SNO with Steel Mounting Hole Plugs

R1806 .5. 3./R1806 .C. 3.

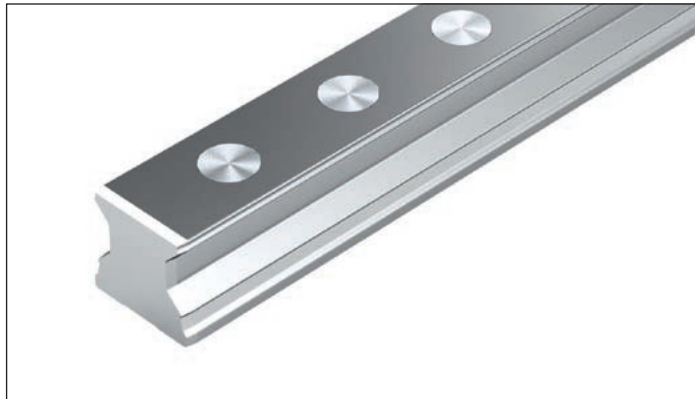

For mounting from above, for steel mounting hole plugs (not included)

Notes

- ▶ Steel mounting hole plugs are not supplied with the roller guide rails. Must be ordered separately (see “Accessories for Roller Guide Rails”).
- ▶ Order the mounting tool along with the plugs (see “Accessories for Roller Guide Rails”)!
- ▶ Follow the mounting instructions!
- ▶ Send for the publication “Mounting Instructions for Roller Rail Systems.”
- ▶ Composite roller guide rails also available.

Roller guide rails R1806 .C. 3. with flat underside for mounting on components made of cast mineral materials. In size 35-65 and accuracy class H, P, SP, GP available, UP on request.

Part numbers

Size	Roller guide rail with size	Accuracy class					Number of sections		Hole spacing T_2 (mm)	Recommended rail lengths $L = n_B \cdot T_2 - 4 \text{ mm}$ Maximum number of bores n_B	
		H	P	SP	GP	UP	One-piece	Composite			
25	R1806 25	3	2	1	8	–	31, ...	3, ...	30.0		133
30 ^{*)}	R1806 75	3	2	1	8	–	31, ...	3, ...	40.0		100
35	R1806 35	3	2	1	8	9	31, ...	3, ...	40.0		100
45	R1806 45	3	2	1	8	9	31, ...	3, ...	52.5		76
55	R1806 55	3	2	1	8	9	31, ...	3, ...	60.0		66
65	R1806 65	3	2	1	8	9	31, ...	3, ...	75.0		53

^{*)} In preparation

Ordering example 1 (up to L_{\max})

Options:

- ▶ Roller guide rail SNS
- ▶ Size 35
- ▶ Accuracy class P
- ▶ One-piece
- ▶ Rail length
L = 1676 mm

Part number:

R1806 352 31, 1676 mm

Ordering example 2 (over L_{\max})

Options:

- ▶ Roller guide rail SNS
- ▶ Size 35
- ▶ Accuracy class P
- ▶ **Composite (2 pieces)**
- ▶ Rail length
L = 5036 mm

Part number:

R1806 352 32, 5036 mm

Ordering example 3 (up to L_{\max} with flat underside)

Options:

- ▶ Roller guide rail SNO
- ▶ Size 35
- ▶ Accuracy class P
- ▶ One-piece
- ▶ Rail length
L = 1676 mm

Part number:

R1806 3C2 31, 1676 mm

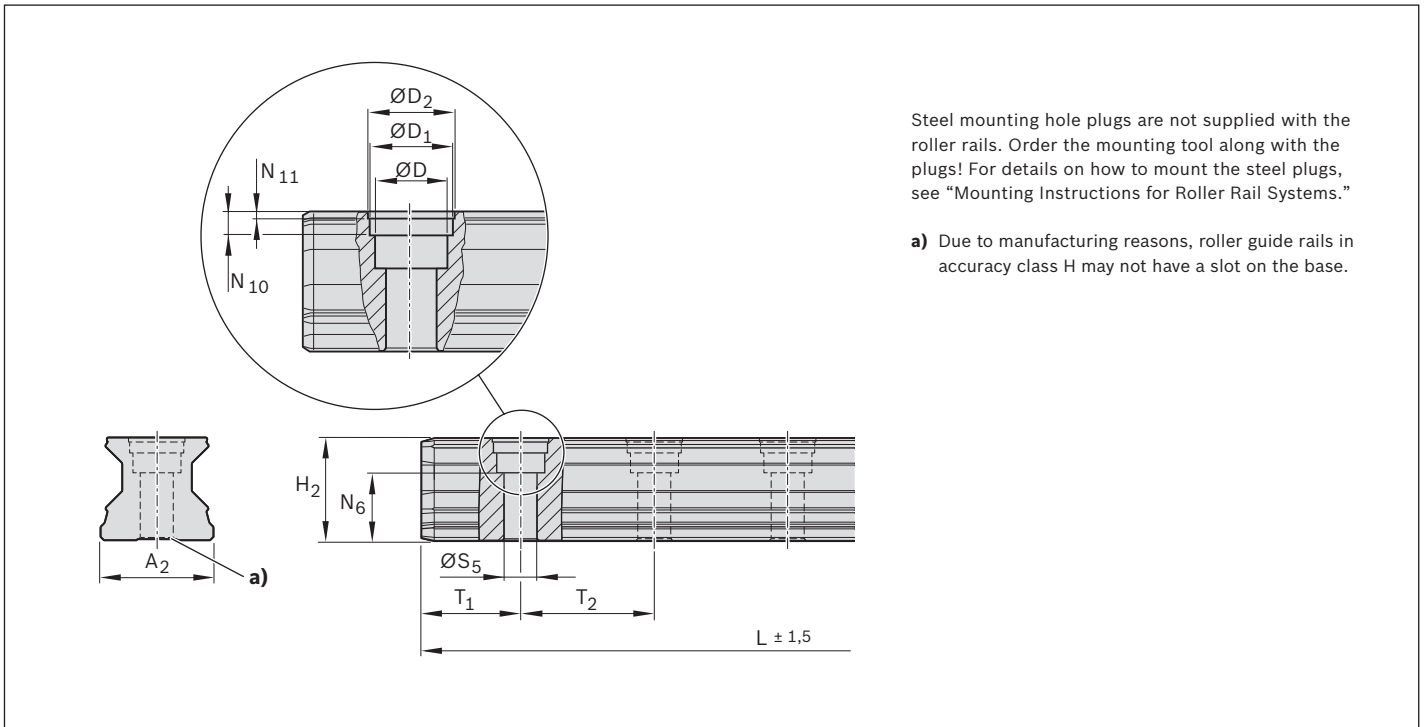

Steel mounting hole plugs are not supplied with the roller rails. Order the mounting tool along with the plugs! For details on how to mount the steel plugs, see "Mounting Instructions for Roller Rail Systems."

a) Due to manufacturing reasons, roller guide rails in accuracy class H may not have a slot on the base.

Dimensions (mm)

Size	A ₂	D	D ₁	D ₂	H ₂	L _{max} ¹⁾	N ₆ ^{±0.5}	N ₁₀	N ₁₁	S ₅	T _{1 min}	T _{1 s} ²⁾	T ₂	Mass (kg/m)
25	23	11	12.55	13	23.40	3986	14.3	3.7	0.90	7	10	13.00	30.0	3.1
30 ^{*)}	28	15	17.55	18	27.80	3996	16.8	0.9	3.60	9	12	18.00	40.0	4.3
35	34	15	17.55	18	30.80	3996	19.4	3.6	0.90	9	12	18.00	40.0	6.3
45	45	20	22.55	23	38.80	3986	22.4	8.0	1.45	14	16	24.25	52.5	10.3
55	53	24	27.55	28	47.55	3956	28.7	8.0	1.45	16	18	28.00	60.0	13.1
65	63	26	29.55	30	57.85	3971	36.5	8.0	1.45	18	20	35.50	75.0	17.4

^{*)} In preparation

1) Sizes 30 and 35: one-piece length up to 5996 mm also available

Size 45: one-piece length up to 5981 mm also available

Size 55: one-piece length up to 5936 mm also available

Size 65: one-piece length up to 5921 mm also available

2) Preferred dimension T_{1s} with tolerances ± 0.75

SNS for Mounting from Below

R1807 .0. 3.



For mounting from below

Notes

- ▶ Follow the mounting instructions!
- ▶ Send for the publication “Mounting Instructions for Roller Rail Systems.”
- ▶ Composite roller guide rails also available.

Part numbers

Size	Roller guide rail with size	Accuracy class					Number of sections		Hole spacing T_2 (mm)	Recommended rail lengths $L = n_B \cdot T_2 - 4 \text{ mm}$ Maximum number of bores n_B	
		H	P	SP	GP	UP	One-piece	Composite			
25	R1807 20	3	2	1	8	9	31, ...	3, ...	30.0		133
30 ^{*)}	R1807 70	3	2	1	8	9	31, ...	3, ...	40.0		100
35	R1807 30	3	2	1	8	9	31, ...	3, ...	40.0		100
45	R1807 40	3	2	1	8	9	31, ...	3, ...	52.5		76
55	R1807 50	3	2	1	8	9	31, ...	3, ...	60.0		66
65	R1807 60	3	2	1	8	9	31, ...	3, ...	75.0		53

*) In preparation

Ordering example 1 (up to L_{\max})

Options:

- ▶ Roller guide rail SNS
- ▶ Size 35
- ▶ Accuracy class P
- ▶ One-piece
- ▶ Rail length
L = 1676 mm

Part number:

R1807 302 31, 1676 mm

Ordering example 2 (over L_{\max})

Options:

- ▶ Roller guide rail SNS
- ▶ Size 35
- ▶ Accuracy class P
- ▶ **Composite (2 pieces)**
- ▶ Rail length
L = 5036 mm

Part number:

R1807 302 32, 5036 mm

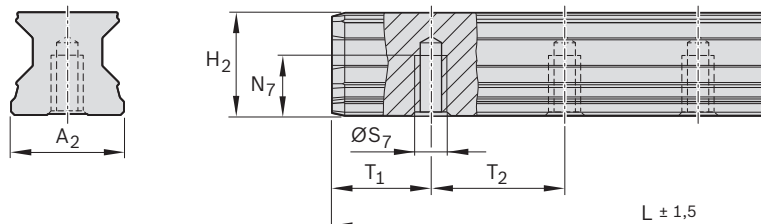
**Dimensions (mm)**

Size	A_2	H_2	$L_{\max}^{1)}$	N_7	S_7	$T_{1\min}$	$T_{1s}^{2)}$	T_2	Mass (kg/m)
25	23	23.40	3986	12	M6	10	13.00	30.0	3.1
30^{*)}	28	28.00	3996	15	M8	12	18.00	40.0	4.3
35	34	30.80	3996	15	M8	12	18.00	40.0	6.3
45	45	38.80	3986	19	M12	16	24.25	52.5	10.3
55	53	47.55	3956	22	M14	18	28.00	60.0	13.1
65	63	57.85	3971	25	M16	20	35.50	75.0	17.4

***)** In preparation

- 1)** Sizes 30 and 35: one-piece length up to 5996 mm also available
 Size 45: one-piece length up to 5981 mm also available
 Size 55: one-piece length up to 5936 mm also available
 Size 65: one-piece length up to 5921 mm also available
- 2)** Preferred dimension T_{1s} with tolerances ± 0.75

Product Description Roller Runner Blocks, Resist CR

General notes on roller runner blocks, Resist CR

Corrosion-resistant coating Resist CR, matte silver hard chrome plated

Steel roller runner blocks with the corrosion-resistant coating Resist CR, matte silver hard chrome plated.

For part numbers, see the following pages. For dimensions, load capacities, rigidity and moment loads, please refer to the corresponding roller runner blocks R18.. ... 2X.

Effect on tolerance and preload

Different tolerances for Resist CR coating

▲ For roller runner blocks and roller guide rails Resist CR, matte silver hard chrome plated, different tolerances apply for the dimensions H and A₃ (see “Accuracy classes and their tolerances”).

Higher preload for combinations of hard chrome plated roller runner blocks with hard chrome plated roller guide rails

On the combination of hard chrome plated roller runner blocks with preload C2 and hard chrome plated roller guide rails, the preload increases by approx. half a preload class.

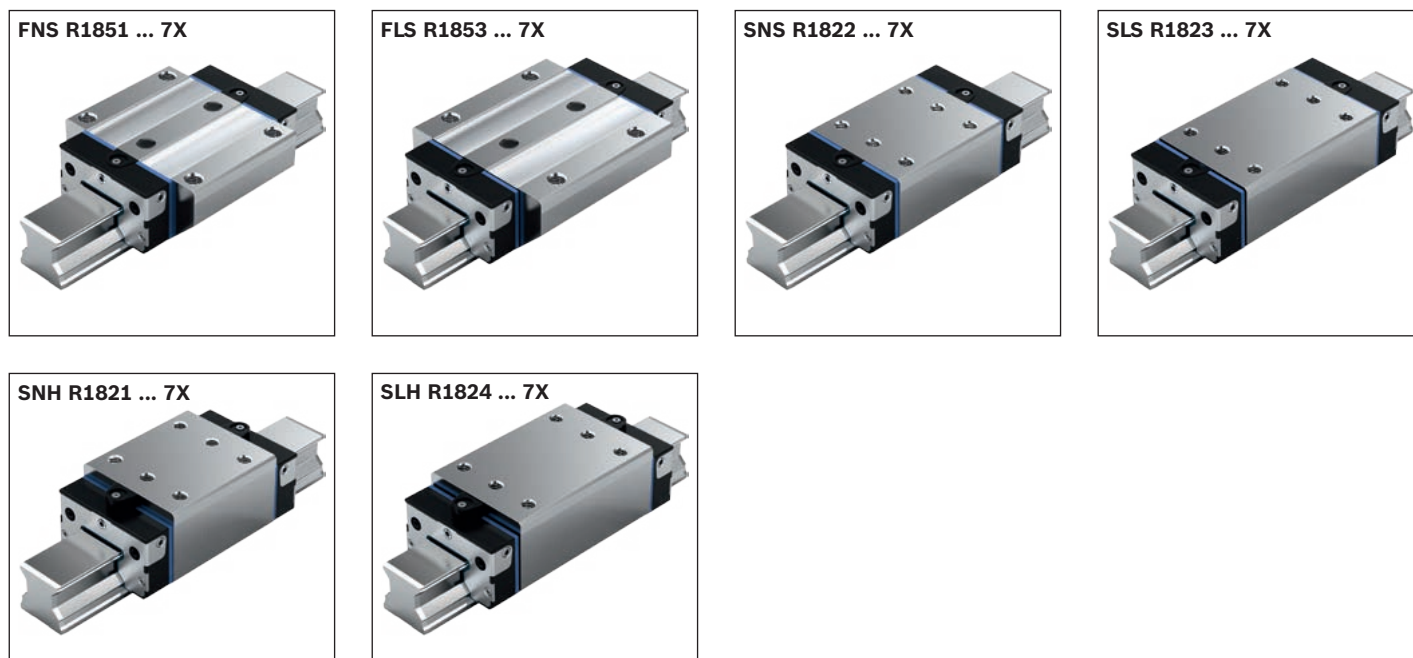

Part numbers Resist CR, matte silver hard chrome plated

Size	Roller runner block with size	Preload class		Accuracy class ¹⁾		Seal DS
		C2	H	H	H	
R1851 ... 7. FNS – Flanged, normal, standard height						
25 ^{*)}	R1851 2	2	3	3	3	7X
30 ^{*)}	R1851 7	2	3	3	3	7X
35	R1851 3	2	3	3	3	7X
45	R1851 4	2	3	3	3	7X
55	R1851 5	2	3	3	3	7X
65 ^{*)}	R1851 6	2	3	3	3	7X
R1853 ... 7. FLS – Flanged, long, standard height						
25 ^{*)}	R1853 2	2	3	3	3	7X
30 ^{*)}	R1853 7	2	3	3	3	7X
35	R1853 3	2	3	3	3	7X
45	R1853 4	2	3	3	3	7X
55	R1853 5	2	3	3	3	7X
65 ^{*)}	R1853 6	2	3	3	3	7X
R1822 ... 7. SNS – Slimline, normal, standard height						
25 ^{*)}	R1822 2	2	3	3	3	7X
30 ^{*)}	R1822 7	2	3	3	3	7X
35	R1822 3	2	3	3	3	7X
45	R1822 4	2	3	3	3	7X
55	R1822 5	2	3	3	3	7X
65 ^{*)}	R1822 6	2	3	3	3	7X
R1823 ... 7. SLS – Slimline, long, standard height						
25 ^{*)}	R1823 2	2	3	3	3	7X
30 ^{*)}	R1823 7	2	3	3	3	7X
35	R1823 3	2	3	3	3	7X
45	R1823 4	2	3	3	3	7X
55	R1823 5	2	3	3	3	7X
65 ^{*)}	R1823 6	2	3	3	3	7X
R1821 ... 7. SNH – Slimline, normal, high						
25 ^{*)}	R1821 2	2	3	3	3	7X
30 ^{*)}	R1821 7	2	3	3	3	7X
35	R1821 3	2	3	3	3	7X
45	R1821 4	2	3	3	3	7X
55	R1821 5	2	3	3	3	7X
R1824 ... 7. SLH – Slimline, long, high						
25 ^{*)}	R1824 2	2	3	3	3	7X
30 ^{*)}	R1824 7	2	3	3	3	7X
35	R1824 3	2	3	3	3	7X
45	R1824 4	2	3	3	3	7X
55	R1824 5	2	3	3	3	7X

*) In preparation

1) Accuracy classes P and SP on request

Product Description Roller Guide Rails, Resist CR, Matte Silver Hard Chrome Plated

General notes on roller guide rails, Resist CR

Corrosion-resistant coating Resist CR, matte silver hard chrome plated

Steel roller guide rails with the corrosion-resistant coating Resist CR, matte silver hard chrome plated.

For part numbers, see the following page. For recommended rail lengths to $L_{\max.} < 4$ m, dimensions and weights, please refer to the corresponding standard steel roller guide rails.

Effect on tolerance and preload

Different tolerances for Resist CR coating

⚠ For roller runner blocks and roller guide rails Resist CR, matte silver hard chrome plated, different tolerances apply for the dimensions H and A_3 (see “Accuracy classes and their tolerances”).

Higher preload for combinations of hard chrome plated roller runner blocks with hard chrome plated roller guide rails

On the combination of hard chrome plated roller runner blocks with preload C2 and hard chrome plated roller guide rails, the preload increases by approx. half a preload class.

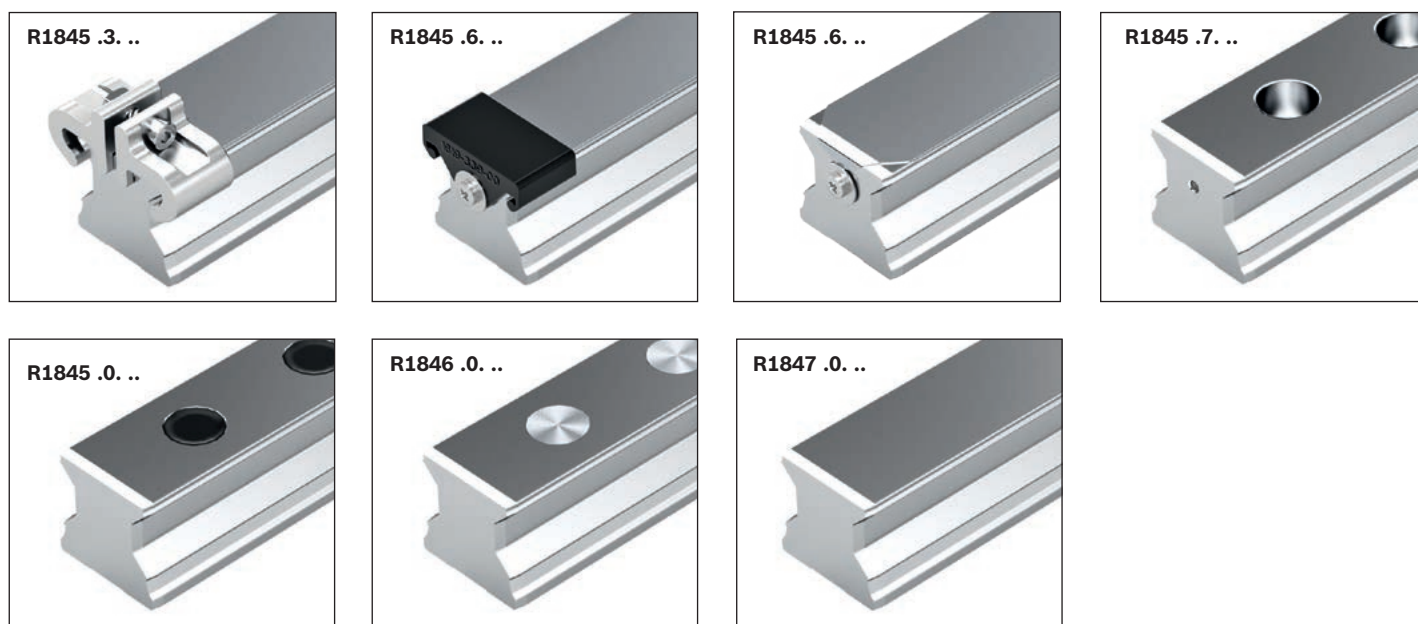

Part numbers Resist CR, matte silver hard chrome plated

Size	Roller guide rail with size	Accuracy class ¹⁾ H	Number of sections	
			One-piece	Composite
R1845 .3. .. SNS with cover strip and strip clamps				
25	R1845 23	3	41,	4., ...
30*)	R1845 73	3	41,	4., ...
35	R1845 33	3	71,	7., ...
45	R1845 43	3	71,	7., ...
55	R1845 53	3	71,	7., ...
65	R1845 63	3	71,	7., ...
R1845 .6. .. SNS with cover strip and protective end caps				
25	R1845 26	3	41,	4., ...
30*)	R1845 76	3	41,	4., ...
35	R1845 36	3	71,	7., ...
45	R1845 46	3	71,	7., ...
55	R1845 56	3	71,	7., ...
65	R1845 66	3	71,	7., ...
R1845 .7. .. SNS for cover strip				
25	R1845 27	3	41,	4., ...
30*)	R1845 77	3	41,	4., ...
35	R1845 37	3	41,	4., ...
45	R1845 47	3	41,	4., ...
55	R1845 57	3	41,	4., ...
65	R1845 67	3	41,	4., ...
R1845 .0. .. SNS with plastic mounting hole plugs				
25	R1845 20	3	41,	4., ...
30*)	R1845 70	3	41,	4., ...
35	R1845 30	3	41,	4., ...
45	R1845 40	3	41,	4., ...
55	R1845 50	3	41,	4., ...
65	R1845 60	3	41,	4., ...
R1846 .0. .. SNS with steel mounting hole plugs				
25	R1846 20	3	41,	4., ...
30*)	R1846 70	3	41,	4., ...
35	R1846 30	3	41,	4., ...
45	R1846 40	3	41,	4., ...
55	R1846 50	3	41,	4., ...
65	R1846 60	3	41,	4., ...
R1847 .0. .. SNS for mounting from below				
25	R1847 20	3	41,	4., ...
30*)	R1847 70	3	41,	4., ...
35	R1847 30	3	41,	4., ...
45	R1847 40	3	41,	4., ...
55	R1847 50	3	41,	4., ...
65	R1847 60	3	41,	4., ...

*) In preparation

1) Accuracy classes P and SP on request

Product Description Roller Guide Rails, Resist CR, Black Hard Chrome Plated

General notes on roller guide rails, Resist CR

Corrosion-resistant coating Resist CR: black hard chrome plated

Steel roller guide rails with the corrosion-resistant coating Resist CR, black hard chrome plated.

For part numbers, see the following page. For recommended rail lengths to $L_{\max.} < 4$ m, dimensions and weights, please refer to the corresponding standard steel roller guide rails.

Effect on tolerance and preload

Different tolerances for Resist CR coating

▲ For roller runner blocks and roller guide rails Resist CR, black hard chrome plated, different tolerances apply for the dimensions H and A_3 (see “Accuracy classes and their tolerances”).

Higher preload for combinations of hard chrome plated roller runner blocks with hard chrome plated roller guide rails

On the combination of hard chrome plated roller runner blocks with preload C2 and hard chrome plated roller guide rails, the preload increases by approx. half a preload class.

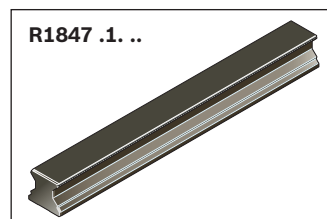
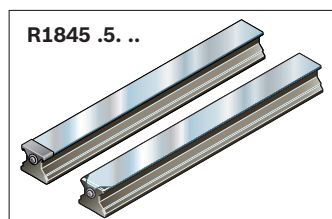

Part numbers Resist CR, black hard chrome plated

Size	Roller guide rail with size	Accuracy class ¹⁾ H	Number of sections	
			One-piece	Composite
R1845 .5. .. SNS with cover strip²⁾ and protective end caps				
25	R1845 25	3	41,	4., ...
30*)	R1845 75	3	41,	4., ...
35	R1845 35	3	71,	7., ...
45	R1845 45	3	71,	7., ...
55	R1845 55	3	71,	7., ...
65	R1845 65	3	71,	7., ...
R1845 .8. .. SNS for cover strip				
25	R1845 28	3	41,	4., ...
30*)	R1845 78	3	41,	4., ...
35	R1845 38	3	41,	4., ...
45	R1845 48	3	41,	4., ...
55	R1845 58	3	41,	4., ...
65	R1845 68	3	41,	4., ...
R1845 .1. .. SNS with plastic mounting hole plugs				
25	R1845 21	3	41,	4., ...
30*)	R1845 71	3	41,	4., ...
35	R1845 31	3	41,	4., ...
45	R1845 41	3	41,	4., ...
55	R1845 51	3	41,	4., ...
65	R1845 61	3	41,	4., ...
R1847 .1. .. SNS for mounting from below				
25	R1847 21	3	41,	4., ...
30*)	R1847 71	3	41,	4., ...
35	R1847 31	3	41,	4., ...
45	R1847 41	3	41,	4., ...
55	R1847 51	3	41,	4., ...
65	R1847 61	3	41,	4., ...

*) In preparation

1) Accuracy classes P and SP on request

2) Cover strip not coated

Product Description

Characteristic features

- ▶ Wide runner blocks for applications with high moment loads and enhanced rigidity
- ▶ Improved travel characteristics
- ▶ Four reference edges on roller runner block for precise alignment in machine structure
- ▶ Very high torque capacity
- ▶ Very high torsional moment and torsional rigidity
- ▶ Improved rigidity under lift-off and side loading conditions through four additional mounting screw holes at the center of the runner block
- ▶ Mounting of attachments to runner block from above

Further highlights

- ▶ Lube ports on all sides for maximum ease of maintenance
- ▶ Novel lube duct design minimizes lubricant consumption
- ▶ Runner blocks made from antifriction bearing steel, with hardened and ground raceways (guide rails also with hardened raceways and ground)
- ▶ Smooth running thanks to optimized roller recirculation and guidance
- ▶ Optimized entry-section geometry and high number of rollers per track minimizes variation in elastic deflection
- ▶ Aluminum end caps
- ▶ End seals integrated as standard for better sealing of all raceways and to protect plastic parts

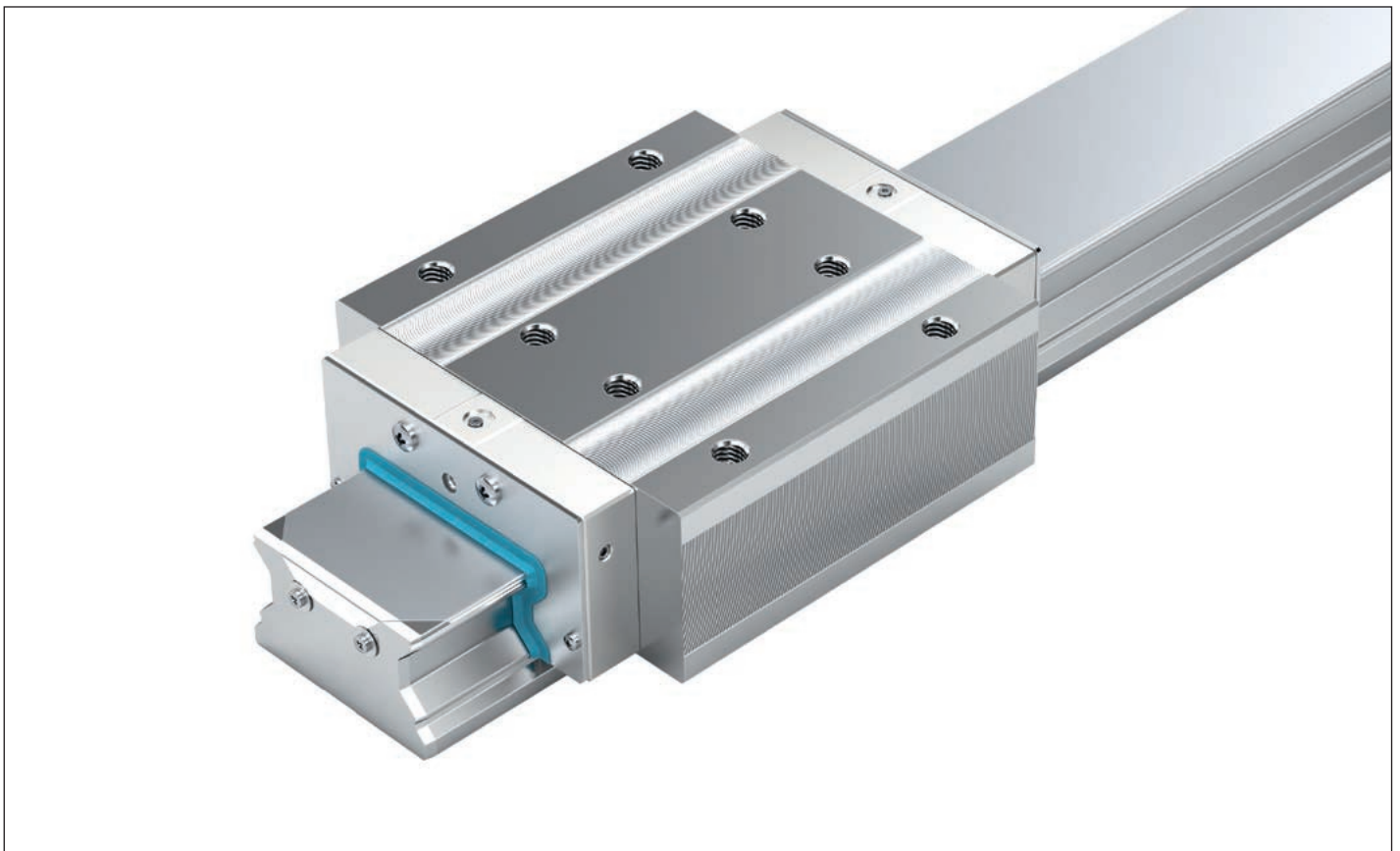

Optional versions

- ▶ Corrosion-resistant wide runner blocks and guide rails
Resist CR, matte silver hard chrome plated, available in accuracy class H (preload C2)



Runner block wide, long, standard height BLS R1872

- ▶ Aluminum end caps
- ▶ End seals integrated as standard for better sealing of all running tracks and to protect plastic parts

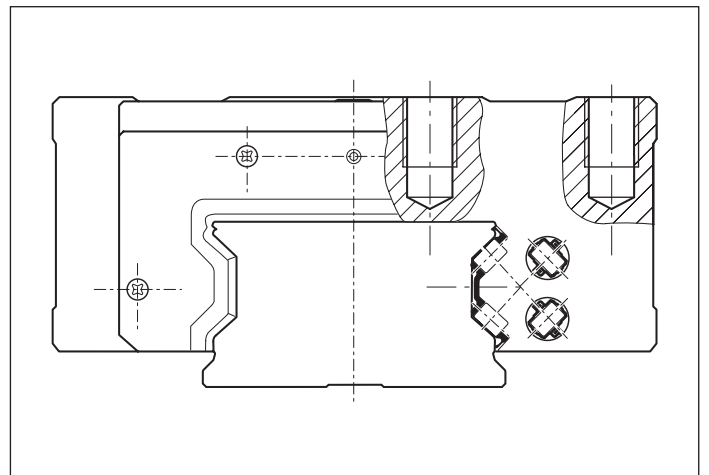

Optimal roller guidance design

- ▶ Smooth running thanks to optimized roller recirculation and guidance

Wide Roller Runner Blocks BLS – Wide, Long, Standard Height Steel R1872 ... 1. / Resist CR R1872 ... 6.



Dynamic characteristics

Speed: $v_{\max} = 3 \text{ m/s}$

Acceleration: $a_{\max} = 150 \text{ m/s}^2$

Recommended preload and accuracy class combinations

- ▶ For preload class C2: H and P (preferred)
- ▶ For preload class C3: P and SP

Note

For runner blocks Resist CR, matte silver hard chrome plated, different tolerances apply for the dimensions H and A_3 (see "Accuracy classes and their tolerances").

On the combination of hard chrome plated runner blocks with preload C2 and hard chrome plated guide rails, the preload increases by approx. half a preload class.

Part numbers wide steel roller runner blocks

Size	Roller runner block with size	Preload class			Accuracy class			Material CS	Seal SS
		C2	C3		H	P	SP		
55/85	R1872 5	2			3	2	1		10
			3				2	1	
65/100	R1872 6	2			3	2	1		10
			3				2	1	

Part numbers wide roller runner blocks, Resist CR, matte silver hard chrome plated

Size	Roller runner block with size	Preload class		Accuracy class		Material CR	Seal SS
		C2		H			
55/85	R1872 5	2		3			60
65/100	R1872 6	2		3			60

Technical data

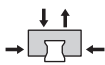
Size	Mass (kg)	Load capacities ¹⁾ (N)		Torsional load moments ¹⁾ (Nm)		Longitudinal load moments ¹⁾ (Nm)	
			C_0	M_t	M_{to}	M_L	M_{Lo}
	m	C					
55/85	11.5	165000	345300	7 450	15 650	4 030	8 440
65/100	20.7	265500	525600	14 300	28 350	7 960	15 760

1) Determination of the dynamic load capacities and moments is based on a travel life of 100,000 m per ISO 14728 Part 1. Often only 50,000 m are actually stipulated. If this is the case, for comparison purposes: Multiply values C, M_t and M_L from the table by 1.23.

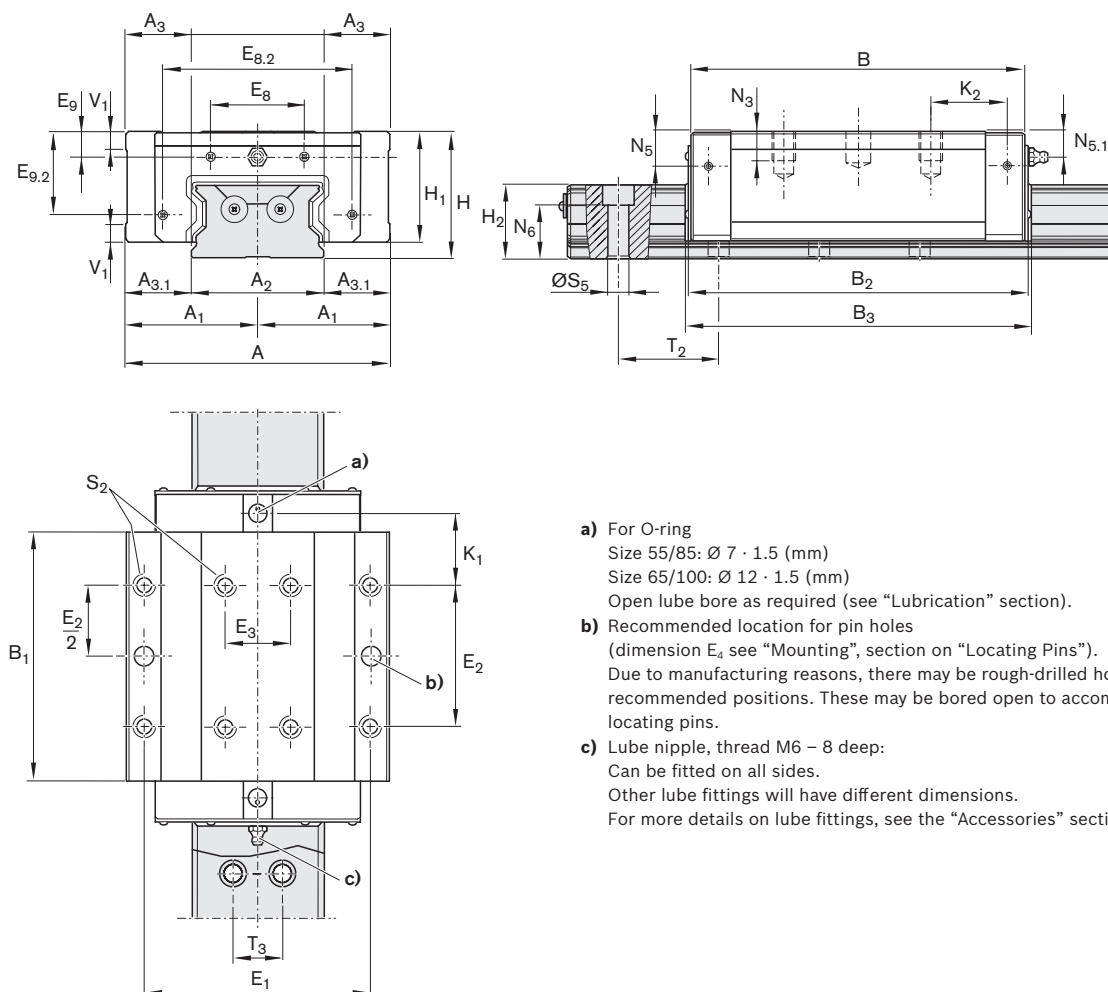

- a) For O-ring
 Size 55/85: Ø 7 · 1.5 (mm)
 Size 65/100: Ø 12 · 1.5 (mm)
 Open lube bore as required (see "Lubrication" section).
- b) Recommended location for pin holes
 (dimension E₄ see "Mounting", section on "Locating Pins").
 Due to manufacturing reasons, there may be rough-drilled holes at the recommended positions. These may be bored open to accommodate the locating pins.
- c) Lube nipple, thread M6 – 8 deep:
 Can be fitted on all sides.
 Other lube fittings will have different dimensions.
 For more details on lube fittings, see the "Accessories" section.

Dimensions (mm)

Size	A	A ₁	A ₂	A ₃	A _{3.1}	B	B ₁	B ₂	B ₃	E ₁	E ₂	E ₃	E ₈	E _{8.2}	E ₉	E _{9.2}
55/85	165	82.5	85	40	40	205.5	162.1	209.5	216	140	95	40	40	113.6	10.75	50.75
65/100	200	100.0	100	50	50	254.0	194.0	258.0	264	172	110	50	72	143.0	19.30	65.00

Size	H	H ₁	H ₂ ¹⁾	K ₁	K ₂	N ₃	N ₅	N _{5.1}	N ₆ ^{±0.5}	S ₂	S ₅	T ₂ ²⁾	T ₃	V ₁
55/85	80	68	47.85	43.55	46.55	19	19	19.0	31.2	M12	14	60	32	12
65/100	100	86	58.15	55.00	59.00	20	27	19.3	39.0	M14	16	75	38	15

1) Dimension H₂ with cover strip

2) Dimension T₂ = hole spacing in the roller guide rail

Wide Roller Guide Rails BNS with Cover Strip Steel R1875 .6. .. / Resist CR R1873 .6. ..



Two-row for mounting from above, with cover strip made of corrosion-resistant spring steel per EN 10088 (with threaded mounting holes on end face)

Notes

- ▶ Secure the cover strip.
- ▶ Screws and washers included in the supply scope.
- ▶ Follow the mounting instructions!
- ▶ Send for the publications “Mounting Instructions for Roller Rail Systems” and “Mounting Instructions for the Cover Strip.”
- ▶ Composite roller guide rails also available.

Part numbers wide steel roller guide rails

Size	Roller guide rail with size	Accuracy class			Number of sections		Hole spacing T_2 (mm)	Recommended rail lengths $L = n_B \cdot T_2 - 4 \text{ mm}$ Maximum number of bores n_B	
		H	P	SP	One-piece	Composite			
55/85	R1875 56	3	2	1	61, ...	6., ...	60.0		66
65/100	R1875 66	3	2	1	61, ...	6., ...	75.0		53

Part numbers roller guide rails, Resist CR

Size	Roller guide rail with size	Accuracy class			Number of sections		Hole spacing T_2 (mm)	Recommended rail lengths $L = n_B \cdot T_2 - 4 \text{ mm}$ Maximum number of bores n_B	
		H			One-piece	Composite			
55/85	R1873 56	3			71, ...	7., ...	60.0		66
65/100	R1873 66	3			71, ...	7., ...	75.0		53

Ordering example 1 (up to L_{\max})

Options:

- ▶ Roller guide rail BNS
- ▶ Size 55/85
- ▶ Accuracy class P
- ▶ One-piece
- ▶ Rail length
 $L = 2516 \text{ mm}$

Part number:

R1875 562 61, 2516 mm

Ordering example 2 (over L_{\max})

Options:

- ▶ Roller guide rail BNS
- ▶ Size 55/85
- ▶ Accuracy class P
- ▶ **Composite (2 pieces)**
- ▶ Rail length
 $L = 7556 \text{ mm}$

Part number:

R1875 562 62, 7556 mm

Part numbers (coating)

- ▶ R1873 .6. 71
(end faces coated)

In composite guide rails the joint faces are hard chrome plated as well as the end faces.

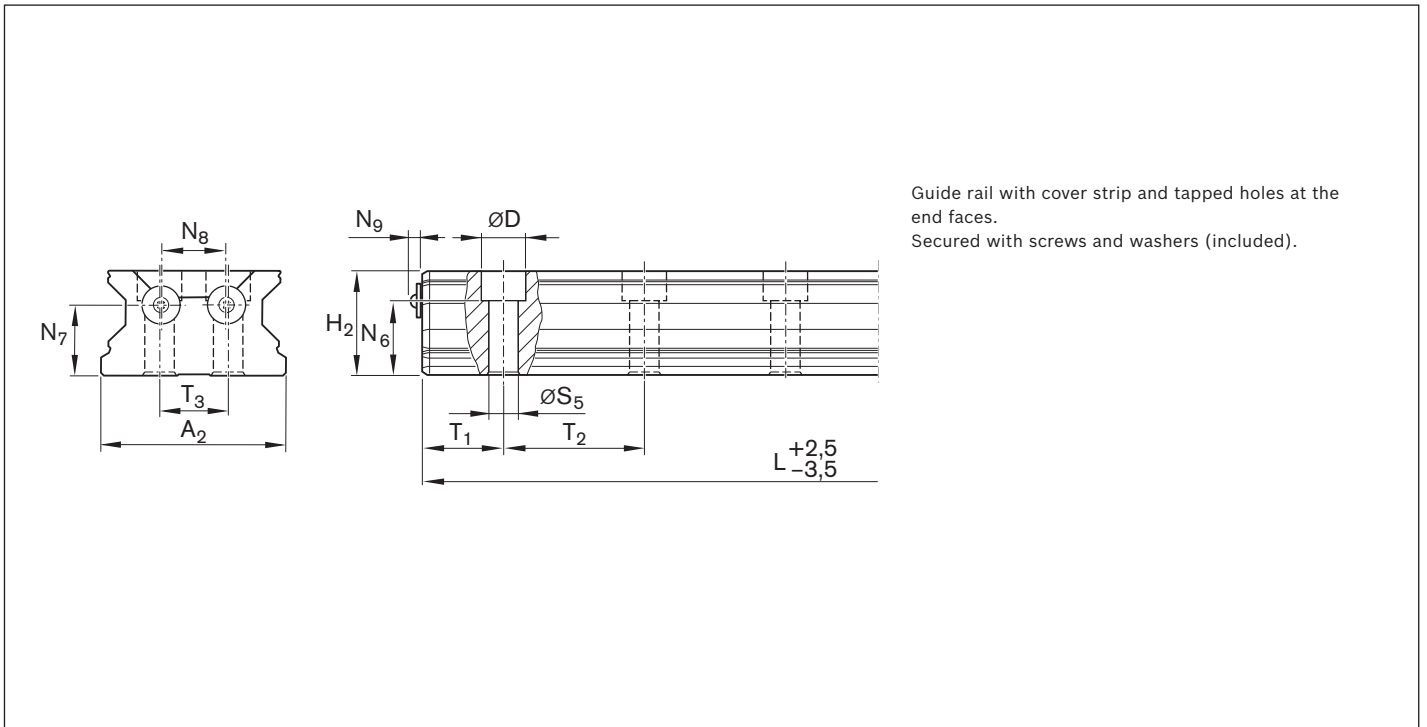
**Dimensions (mm)**

Size	A ₂	D	H ₂ ¹⁾	L _{max}	N ₆ ^{±0.5}	N ₇	N ₈	N ₉	S ₅	T _{1 min} ²⁾	T _{1 S} ³⁾	T ₂	T ₃	Mass (kg/m)
55/85	85	20	47.85	3956	31.2	30	32	4.8	14	18	28.0	60	32	24.7
65/100	100	24	58.15	3971 ⁴⁾	39.0	40	37	4.8	16	20	35.5	75	38	34.7

- 1) Dimension H₂ with cover strip 0.3 mm
- 2) Rails smaller than T_{1 min} have no tapped hole at end face for securing the strip. Secure the cover strip! Follow the mounting instructions!
- 3) Preferred dimension T_{1 S} with tolerances +1/-1.5
- 4) Guide rails R1873 .6. .. Resist CR in lengths of up to 3971 mm only (one-piece)

Product Description

Characteristic features

- ▶ Heavy duty runner blocks for applications requiring extremely high load capacities
- ▶ Maximum rigidity under load from all directions
- ▶ Improved rigidity under lift-off and side loading conditions through three additional mounting screw holes at the center of the runner block
- ▶ High torque capacity
- ▶ Uniform guide rail profile in various versions allows unrestricted interchangeability and combinability of components across all runner block variants
- ▶ Mounting of attachments to runner block from above or below

Further highlights

- ▶ Lube ports on all sides for maximum ease of maintenance
- ▶ Novel lube duct design minimizes lubricant consumption
- ▶ Runner blocks made from antifriction bearing steel, with hardened and ground raceways (guide rails also with hardened raceways and ground)
- ▶ Smooth running thanks to optimized roller recirculation and guidance
- ▶ Optimized entry-section geometry and high number of rollers per track minimizes variation in elastic deflection
- ▶ Aluminum or plastic end caps
- ▶ End seals integrated as standard for better sealing of all raceways and to protect plastic parts

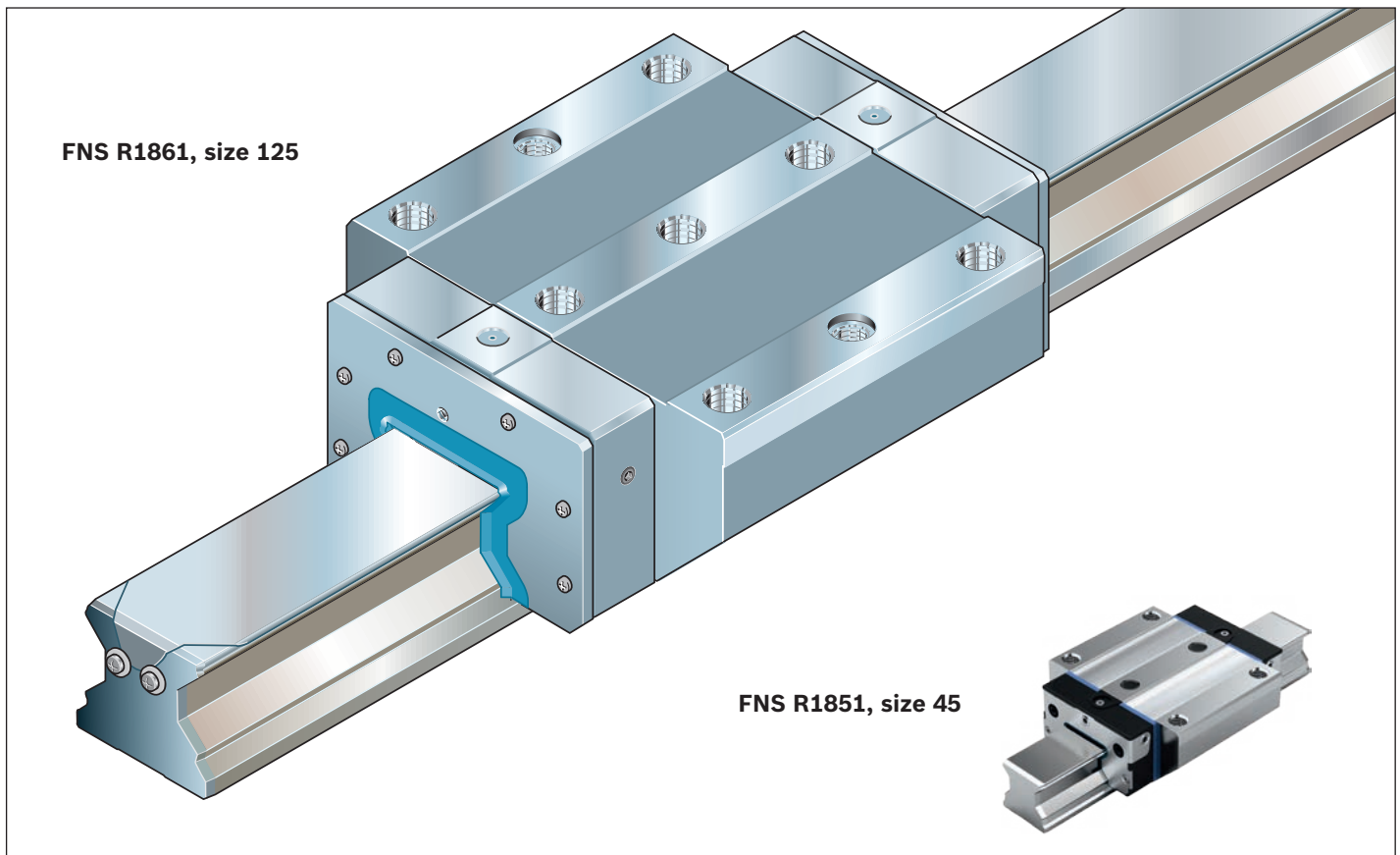

Optional versions

- ▶ Corrosion-resistant heavy duty runner blocks and guide rails Resist CR, matte silver hard chrome plated, available in accuracy class H (preload C2 and C3)

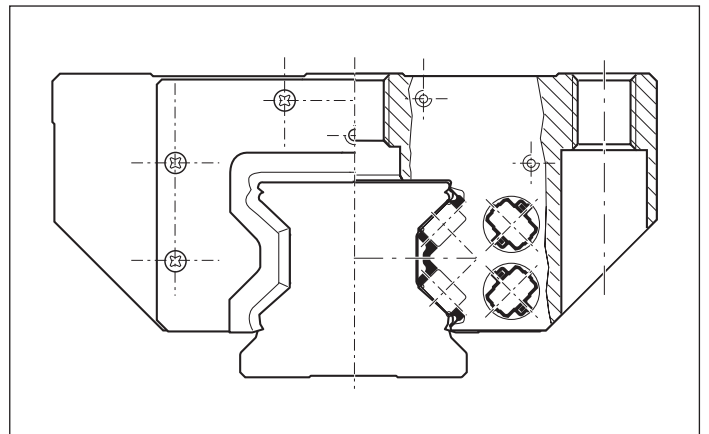
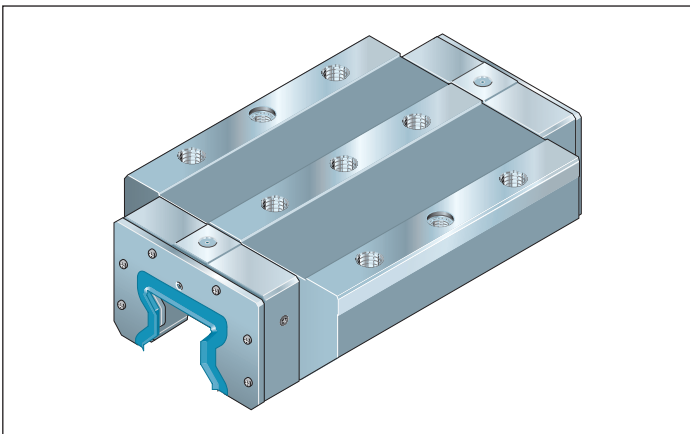

Heavy duty roller rail systems for heavy duty applications

- ▶ Aluminum or plastic end caps
- ▶ End seals as standard

Optimal roller guidance design

- ▶ Smooth running thanks to optimized roller recirculation and guidance

Heavy Duty Roller Runner Blocks FNS – Flange, Normal, Standard Height, Steel R1861 ... 1. / Resist CR R1861 ... 6.

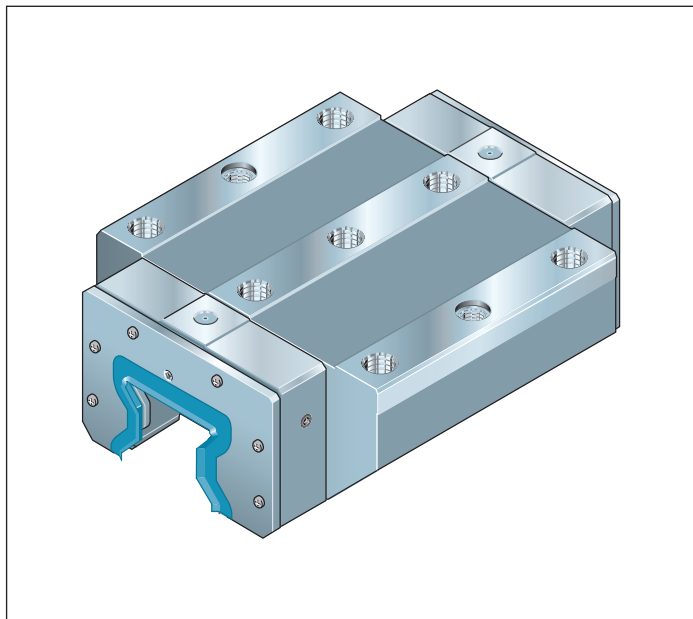

Dynamic characteristics

Speed: $v_{\max} = 2 \text{ m/s}$

Acceleration: $a_{\max} = 150 \text{ m/s}^2$

Recommended preload and accuracy class combinations

- ▶ For preload class C2: H and P (preferred)
- ▶ For preload class C3: P and SP

Note

For runner blocks Resist CR, matte silver hard chrome plated, different tolerances apply for the dimensions H and A_3 (see “Accuracy classes and their tolerances”).

On the combination of hard chrome plated roller runner blocks and hard chrome plated roller guide rails, the preload increases by approx. half a preload class.

For short-stroke applications ($< 2 \cdot B_1$), use additional lube ports: Size 125: B_4 and N_7

All lube ports with thread M8x1 (tapped holes in the metal for size 125).



Part numbers heavy duty steel roller runner blocks

Size	Roller runner block with size	Preload class			Accuracy class			Material CS	Seal SS
		C2	C3		H	P	SP		
100	R1861 2	2			3	2	1		10
			3		3	2	1		10
125	R1861 3	2			3	2			10
			3		3	2			10

Part numbers heavy duty roller runner blocks, Resist CR, matte silver hard chrome plated

Size	Roller runner block with size	Preload class		Accuracy class	Material CR	Seal SS
		C2	C3	H		
100	R1861 2	2	3	3		60
125	R1861 3	2	3	3		60

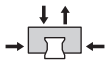
Technical data

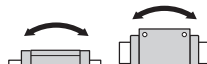
Size	Mass (kg)	Load capacities ¹⁾ (N)		Torsional load moments ¹⁾ (Nm)		Longitudinal load moments ¹⁾ (Nm)	
							
	m	C	C_o	M_t	M_{to}	M_L	M_{Lo}
100	32.0	461000	811700	25720	45290	13550	23850
125	62.1	757200	1324000	54520	95330	29660	51860

1) Determination of the dynamic load capacities and moments is based on a travel life of 100,000 m per ISO 14728 Part 1. Often only 50,000 m are actually stipulated. If this is the case, for comparison purposes: Multiply values C, M_t and M_L from the table by 1.23.

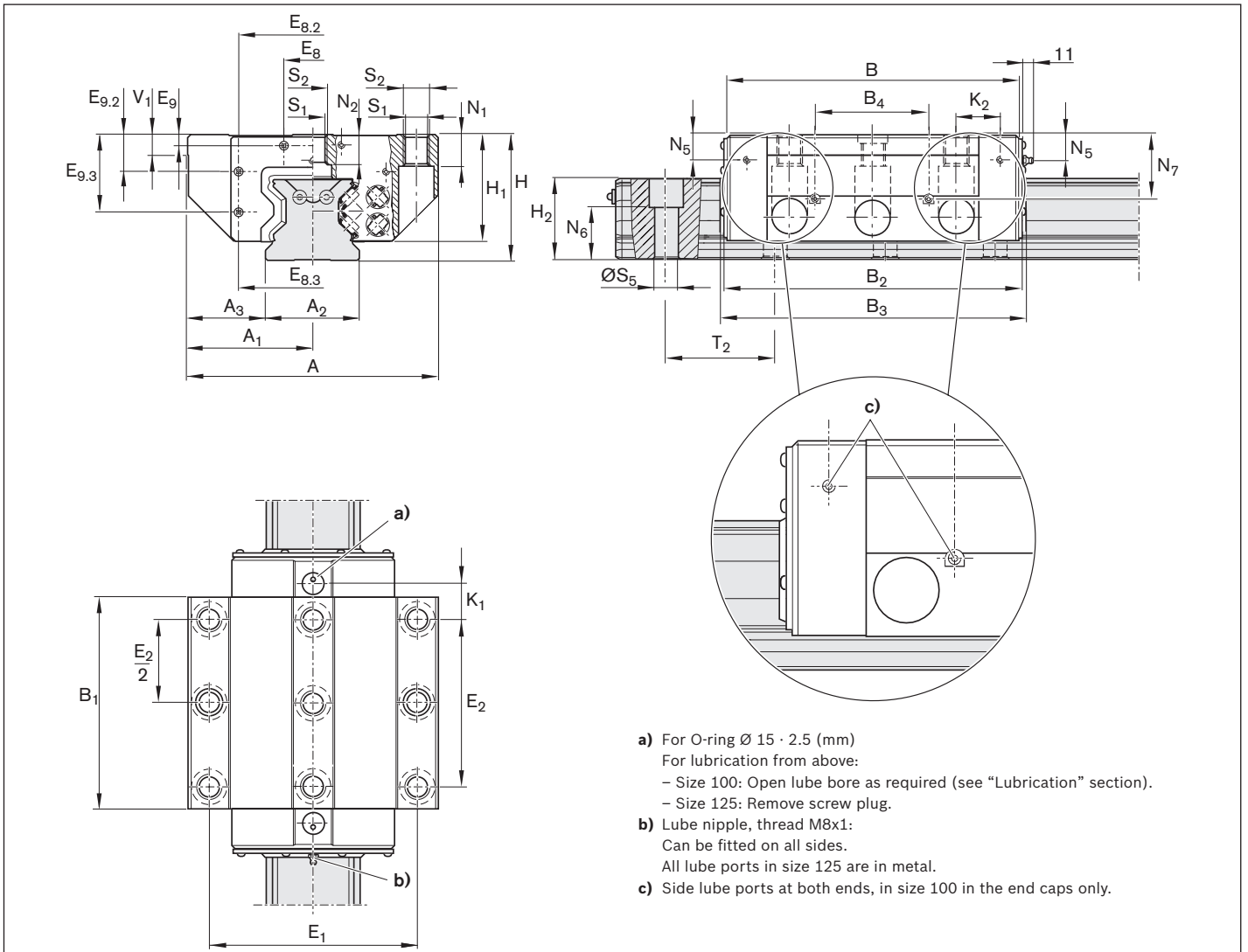
Dimensions (mm)

Size	A	A ₁	A ₂	A ₃	B	B ₁	B ₂	B ₃	B ₄	E ₁	E ₂	E ₈	E _{8.2}	E _{8.3}	E ₉	E _{9.2}	E _{9.3}
100	250	125	100	75.0	296.5	204	301.5	309.5	–	200	150	64	130	162.6	9	29.4	70
125	320	160	125	97.5	371	255	377	386.5	130	270	205	80	205	205.0	12	40.0	92

Size	H	H ₁	H ₂ ¹⁾	K ₁	K ₂	N ₁	N ₂	N ₅	N ₆ ^{2)0.5}	N ₇	S ₁	S ₂	S ₅	T ₂	V ₁
100	120	105.0	87.3	44,0	49,9	30	22	17.5	55.0	–	17.5	M20	25	105	20
125	160	135.5	115.3	50.0	50.0	45	29	29.0	74.5	92	25.0	M27	33	120	25

1) Dimension H₂ with cover strip

2) Dimension T₂ = hole spacing in the roller guide rail

Heavy Duty Roller Runner Blocks FLS – Flanged, Long, Standard Height, Steel R1863 ... 1. / Resist CR R1863 ... 6.

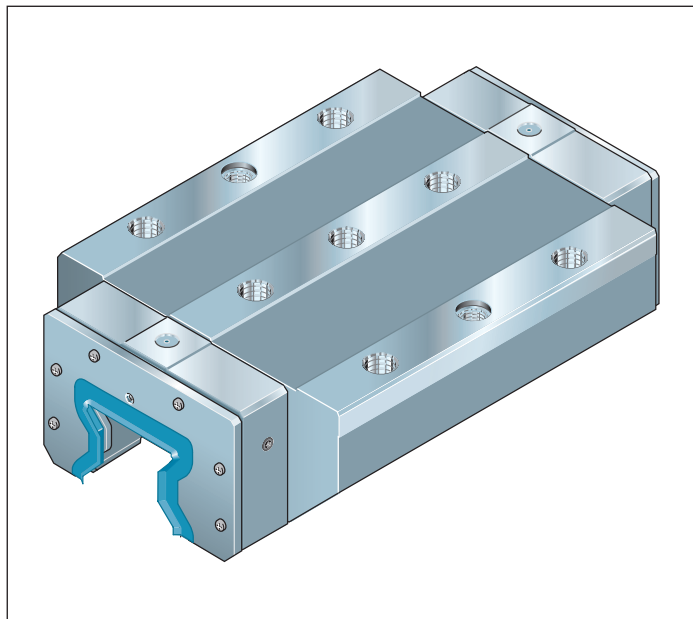

Dynamic characteristics

Speed: $v_{\max} = 2 \text{ m/s}$

Acceleration: $a_{\max} = 150 \text{ m/s}^2$

Recommended preload and accuracy class combinations

- ▶ For preload class C2: H and P (preferred)
- ▶ For preload class C3: P and SP

Note

For runner blocks Resist CR, matte silver hard chrome plated, different tolerances apply for the dimensions H and A_3 (see “Accuracy classes and their tolerances”).

On the combination of hard chrome plated roller runner blocks and hard chrome plated roller guide rails, the preload increases by approx. half a preload class.

For short-stroke applications ($< 2 \cdot B_1$), use additional lube ports: Size 125: B_4 and N_7

All lube ports with thread M8x1 (tapped holes in the metal for size 125).







Part numbers heavy duty steel roller runner blocks

Size	Roller runner block with size	Preload class		Accuracy class			Material CS	Seal SS
		C2	C3	H	P	SP		
100	R1863 2	2		3	2	1		10
			3	3	2	1		10
125	R1863 3	2		3	2			10
			3	3	2			10

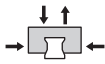
Part numbers heavy duty roller runner blocks, Resist CR, matte silver hard chrome plated

Size	Roller runner block with size	Preload class		Accuracy class	Material CR	Seal SS
		C2	C3	H		
100	R1863 2	2	3	3		60
125	R1863 3	2	3	3		60

Technical data

Size	Mass (kg)	Load capacities ¹⁾ (N)		Torsional load moments ¹⁾ (Nm)		Longitudinal load moments ¹⁾ (Nm)	
							
	m	C	C ₀	M _t	M _{t0}	M _L	M _{L0}
100	42.0	632000	1218000	35300	67900	27200	52400
125	89.8	1020000	1941900	73440	139820	57330	109150

1) Determination of the dynamic load capacities and moments is based on a travel life of 100,000 m per ISO 14728 Part 1. Often only 50,000 m are actually stipulated. If this is the case, for comparison purposes: Multiply values C, M_t and M_L from the table by 1.23.

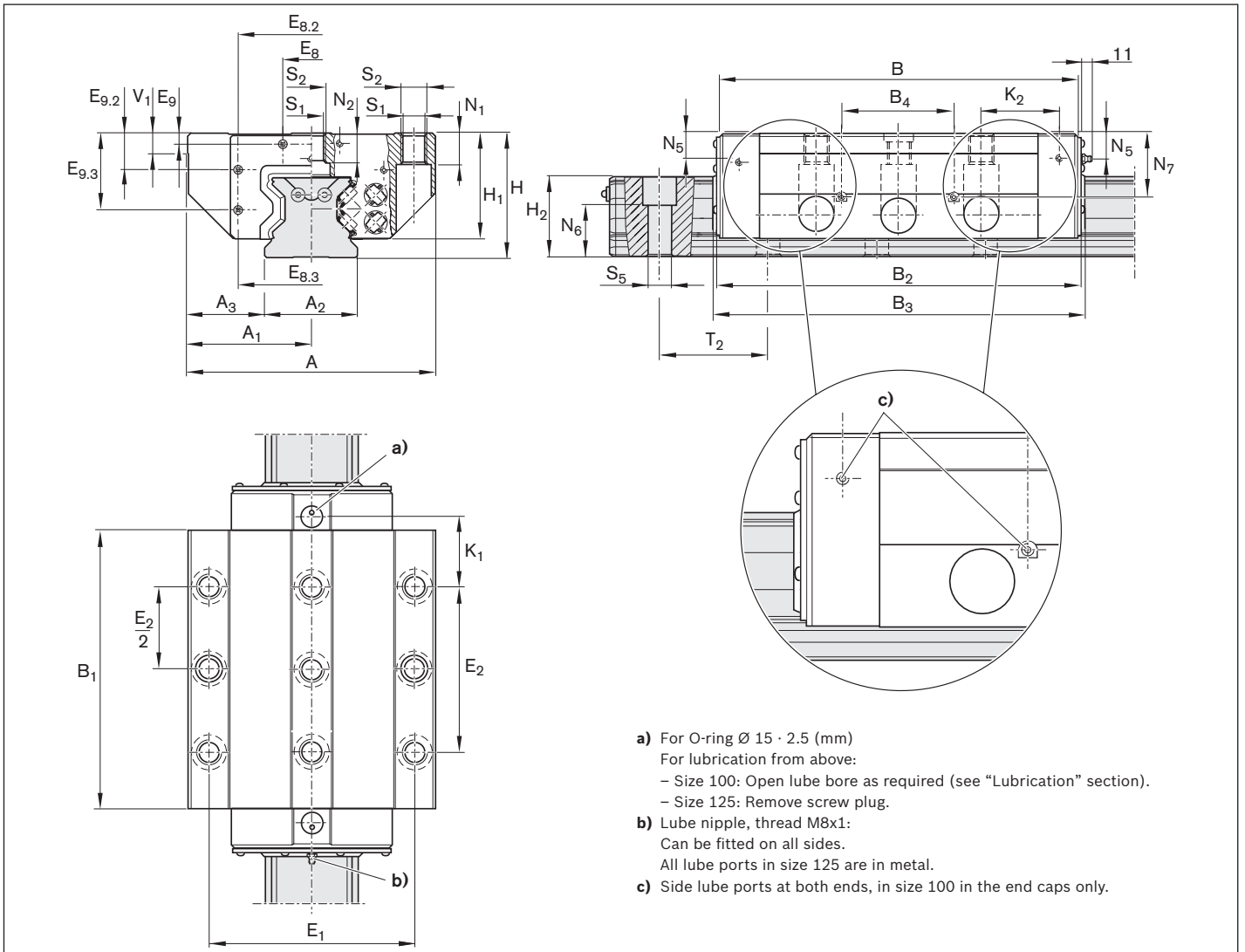
Dimensions (mm)

Size	A	A ₁	A ₂	A ₃	B	B ₁	B ₂	B ₃	B ₄	E ₁	E ₂	E ₈	E _{8.2}	E _{8.3}	E ₉	E _{9.2}	E _{9.3}
100	250	125	100	75.0	380.5	288	385.5	393.5	–	200	230	64	130	162.6	9	29.4	70
125	320	160	125	97.5	476	360	482	491.5	150	270	205	80	205	205.0	12	40.0	92

Size	H	H ₁	H ₂ ¹⁾	K ₁	K ₂	N ₁	N ₂	N ₅	N ₆ ^{20.5}	N ₇	S ₁	S ₂	S ₅	T ₂	V ₁
100	120	105.0	87.3	46.0	51.9	30	22	17.5	55.0	–	17.5	M20	26	105	20
125	160	135.5	115.3	102.5	102.5	45	29	29.0	74.5	92	25.0	M27	33	120	25

1) Dimension H₂ with cover strip

2) Dimension T₂ = hole spacing in the roller guide rail

Heavy Duty Roller Runner Blocks FXS – Flanged, Extra Long, Standard Height, Steel R1854 ... 1.

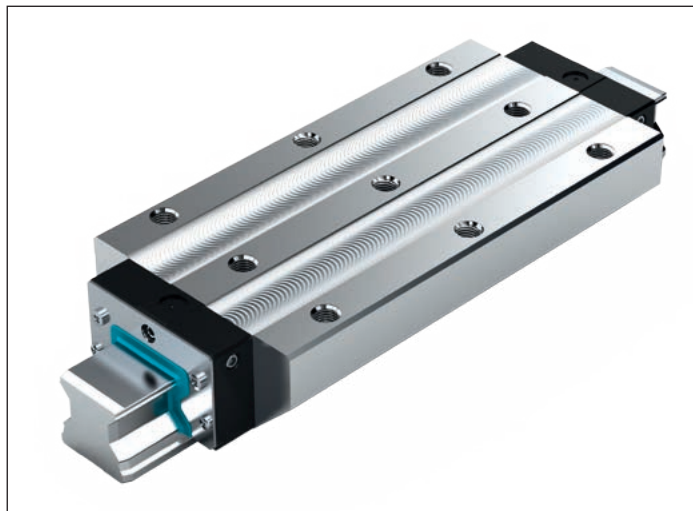

Dynamic characteristics

Speed: $v_{\max} = 3 \text{ m/s}$

Acceleration: $a_{\max} = 150 \text{ m/s}^2$



Recommended preload and accuracy class combinations

- ▶ For preload class C2: H and P (preferred)
- ▶ For preload class C3: P and SP

Part numbers

Size	Roller runner block with size	Preload class		Accuracy class				Seal
		C2	C3	H	P	SP	UP	SS
65	R1854 6	2		3	2	1	9	10
			3		2	1	9	10

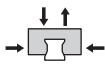
Technical data

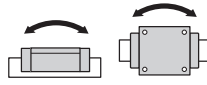
Size	Mass (kg)	Load capacities ¹⁾ (N)		Torsional load moments ¹⁾ (Nm)		Longitudinal load moments ¹⁾ (Nm)				
	m		C	C₀		M_t	M_{t0}		M_L	M_{L0}
65	20.30	366800	792800	13030	28170	15760	34060			

1) Determination of the dynamic load capacities and moments is based on a travel life of 100,000 m per ISO 14728 Part 1. Often only 50,000 m are actually stipulated. If this is the case, for comparison purposes: Multiply values C, M_t and M_L from the table by 1.23.

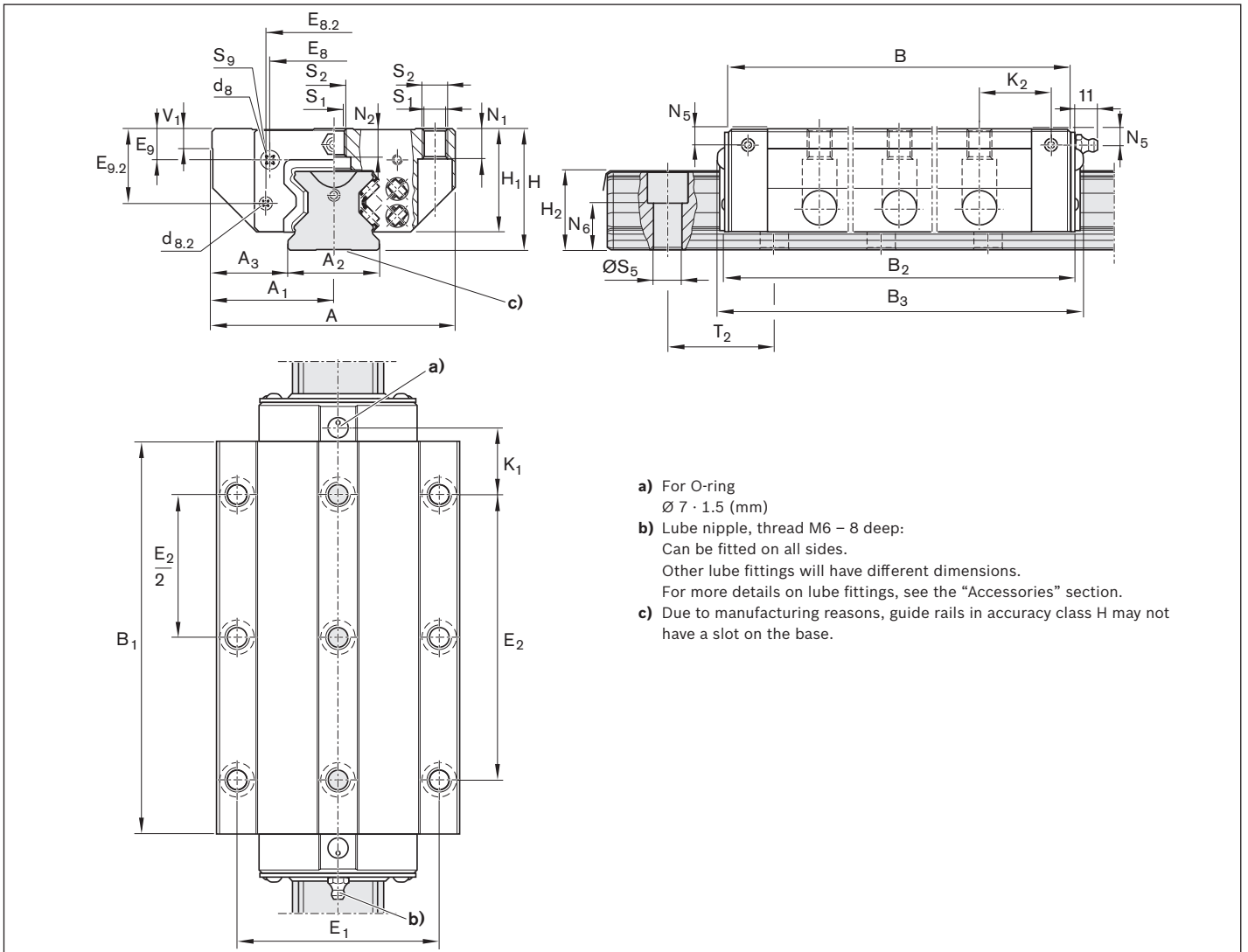

Dimensions (mm)

Size	A	A ₁	A ₂	A ₃	B	B ₁	B ₂	B ₃	d ₈	d _{8.2}	E ₁	E ₂	E ₈	E _{8.2}	E ₉	E _{9.2}
65	170	85	63	53.5	335	275	339.5	345	8	8	142	200	35.0	106.00	9.30	55.00

Size	H	H ₁	H ₂ ²⁾	H ₂ ³⁾	K ₁	K ₂	N ₁	N ₂	N ₅	N ₆ ^{±0.5}	S ₁	S ₂	S ₅	S ₉ ⁴⁾	T ₂ ⁵⁾	V ₁
65	90	76	58.15	57.85	49.5	52.5	23	21.5	9.3	36.5	14.5	M16	18	M4-7deep	75.0	15.0

- 2)** Dimension H₂ with cover strip
3) Dimension H₂ without cover strip
4) Thread for attachments
5) Dimension T₂ = hole spacing in the roller guide rail

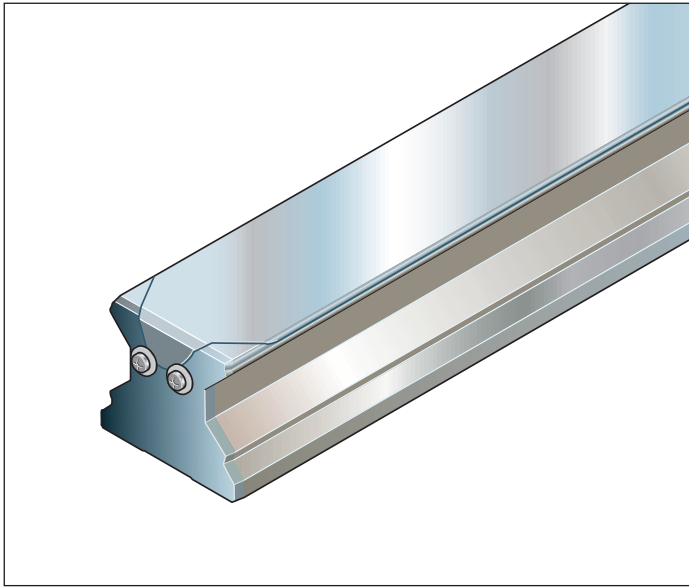
Heavy Duty Roller Guide Rails SNS with Cover Strip, Steel R1835 .6. .. / Resist CR R1865 .6. ..



For mounting from above, with cover strip made of corrosion-resistant spring steel per EN 10088 (with threaded mounting holes on end face)

Notes

- ▶ Secure the cover strip.
- ▶ Screws and washers included in the supply scope.
- ▶ Follow the mounting instructions!
- ▶ Send for the publications “Mounting Instructions for Roller Rail Systems” and “Mounting Instructions for the Cover Strip.”
- ▶ Composite roller guide rails also available.

Part numbers steel roller guide rails

Size	Roller guide rail with size	Accuracy class			Number of sections		Hole spacing T_2 (mm)	Recommended rail lengths $L = n_B \cdot T_2 - 7 \text{ mm}$ Maximum number of bores n_B	
		H	P	SP	One-piece	Composite			
100	R1835 26	3	2	1	61, ...	6., ...	105		35
125	R1835 36	3	2	-	61, ...	6., ...	120		22

Part numbers heavy duty roller guide rails, Resist CR

Size	Roller guide rail with size	Accuracy class			Number of sections		Hole spacing T_2 (mm)	Recommended rail lengths $L = n_B \cdot T_2 - 7 \text{ mm}$ Maximum number of bores n_B	
		H			One-piece	Composite			
100	R1865 26	3			71, ...	7., ...	105		35
125	R1865 36	3			71, ...	7., ...	120		22

Ordering example 1

(up to L_{\max})

Options:

- ▶ Roller guide rail SNS
- ▶ Size 125
- ▶ Accuracy class P
- ▶ One-piece
- ▶ Rail length
 $L = 1637 \text{ mm}$

Part number:

R1835 362 61, 1637 mm

Ordering example 2

(over L_{\max})

Options:

- ▶ Roller guide rail SNS
- ▶ Size 125
- ▶ Accuracy class P
- ▶ **Composite (2 pieces)**
- ▶ Rail length
 $L = 5033 \text{ mm}$

Part number:

R1835 362 62, 5033 mm

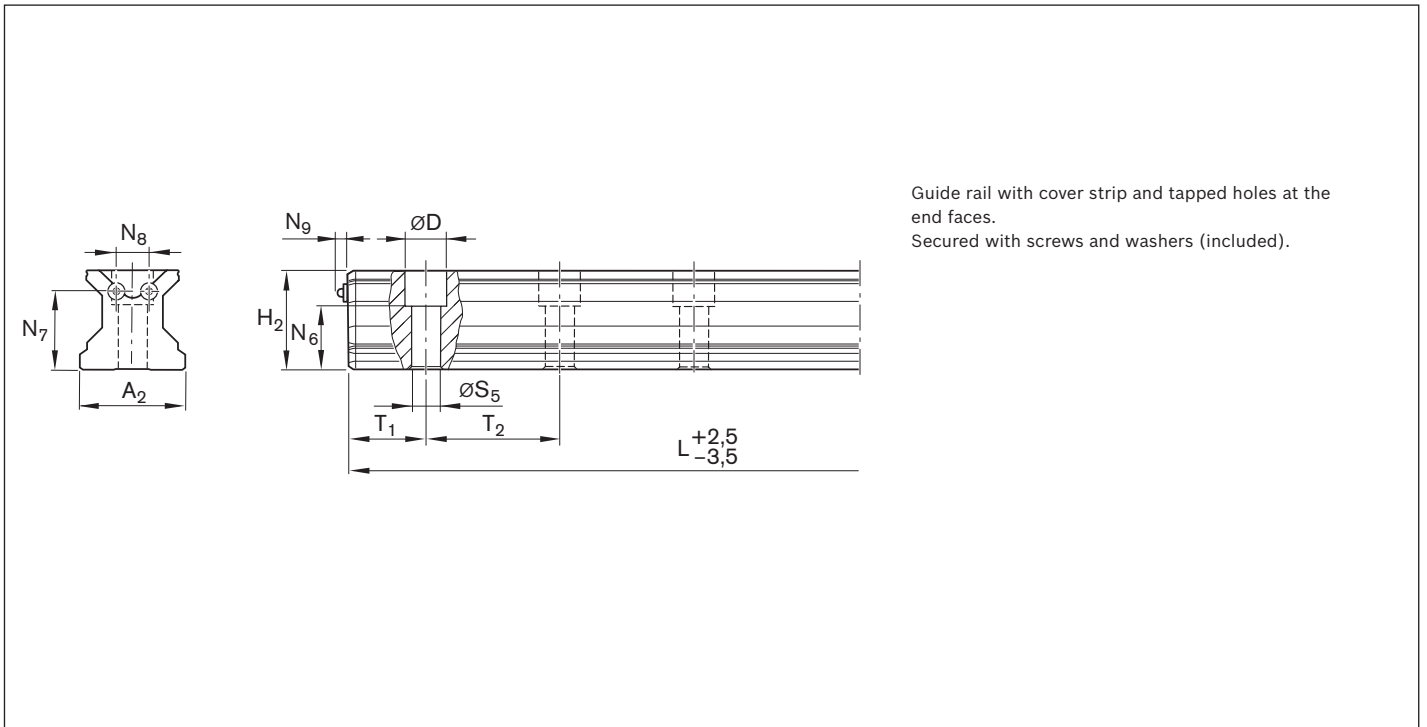
Dimensions (mm)

Size	A ₂	D	H ₂ ¹⁾	L _{max}	N ₆ ^{20.5}	N ₇	N ₈	N ₉	S ₅	T _{1 min} ²⁾	T _{1s} ³⁾	T ₂	Mass (kg/m)
100	100	40	87.3	3986	55.0	65	28	4.8	26	35	49.0	105	42.5
125	125	49	115.3	2760	74.5	91	38	4.8	33	40	56.5	120	75.6

- 1) Dimension H₂ with cover strip 0.3 mm
- 2) Rails smaller than T_{1 min} have no tapped hole at end face for securing the strip. Secure the cover strip! Follow the mounting instructions!
- 3) Preferred dimension T_{1s} with tolerances +1/-1.5

Heavy Duty Roller Guide Rails SNS with Steel Mounting Hole Plugs R1836 .5. ...



For mounting from above, for steel mounting hole plugs (not included)

Notes

- ▶ Steel mounting hole plugs are not supplied with the roller guide rails. Must be ordered separately (see “Accessories for Roller Guide Rails”).
- ▶ Order the mounting tool along with the plugs (see “Accessories for Roller Guide Rails”)!
- ▶ Follow the mounting instructions!
- ▶ Send for the publication “Mounting Instructions for Roller Rail Systems.”
- ▶ Composite roller guide rails also available.

Part numbers

Size	Roller guide rail with size	Accuracy class			Number of sections		Hole spacing T ₂ (mm)	Recommended rail lengths
		H	P	SP	One-piece	Composite		L = n _B · T ₂ - 7 mm Maximum number of bores n _B
100	R1836 25	3	2	1	31, ...	3, ...	105	35

Ordering example 1 (up to L_{max})

Options:

- ▶ Roller guide rail SNS
- ▶ Size 100
- ▶ Accuracy class P
- ▶ One-piece
- ▶ Rail length
L = 1673 mm

Part number:

R1836 352 31, 1673 mm

Ordering example 2 (over L_{max})

Options:

- ▶ Roller guide rail SNS
- ▶ Size 100
- ▶ Accuracy class P
- ▶ **Composite (2 pieces)**
- ▶ Rail length
L = 5768 mm

Part number:

R1836 352 32, 5768 mm

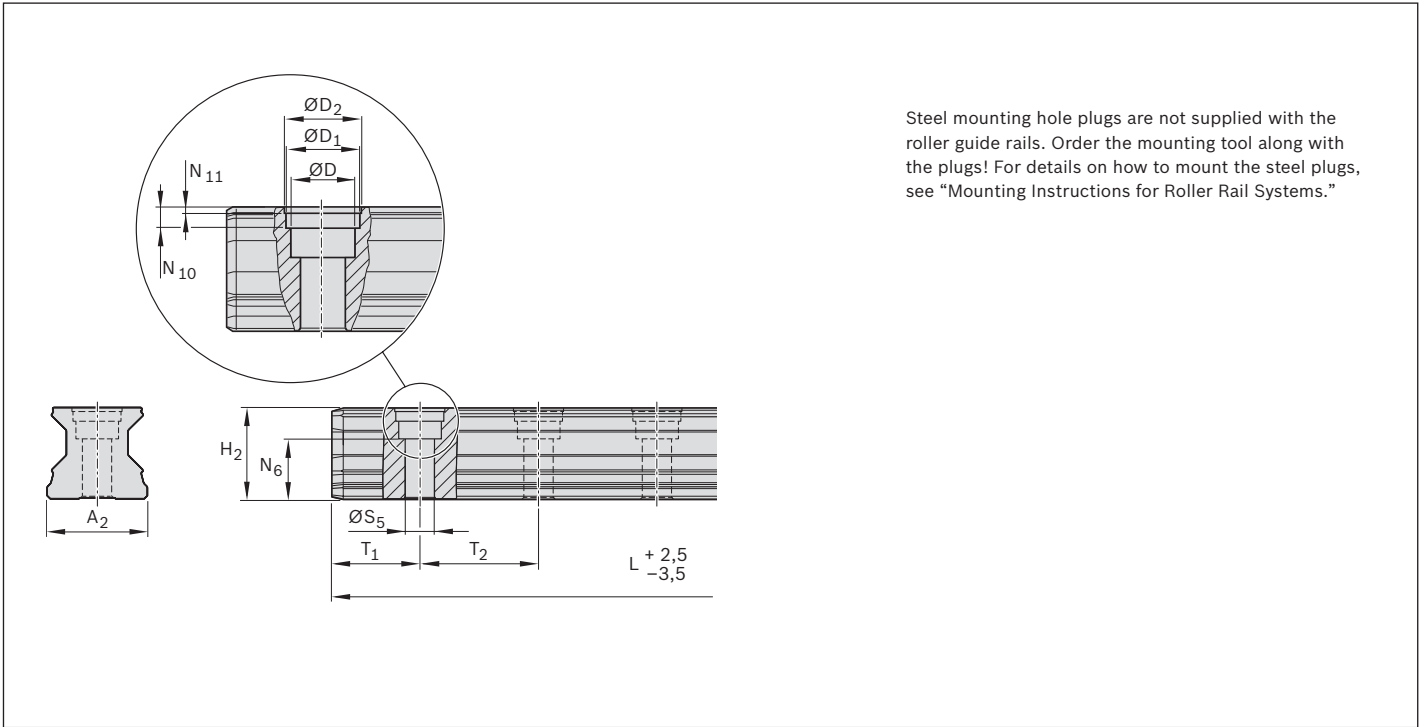

Dimensions (mm)

Size	A ₂	D	D ₁	D ₂	H ₂	L _{max}	N ₆ ^{±0.5}	N ₁₀	N ₁₁	S ₅	T _{1 min}	T _{1 s} ¹⁾	T ₂	Mass (kg/m)
100	100	40	43.55	46	87.00	3986	55.00	9.0	1.60	26	35	49.00	105	42.5

1) Preferred dimension T_{1s} with tolerances +1/-1.5

Overview of Accessories for Roller Runner Blocks

Scraper plate



Lube nipple

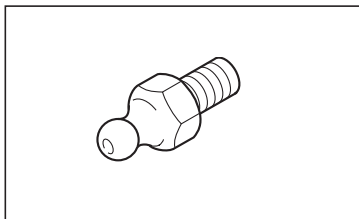

FKM seal



Lube fittings

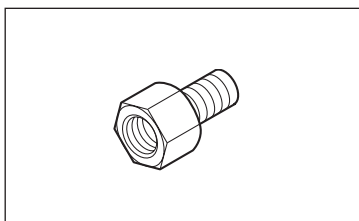

FKM seal set



O-rings

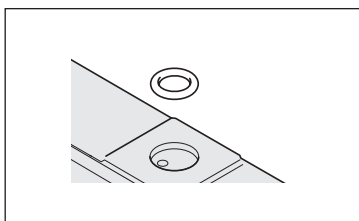

Front lube unit



Bellows

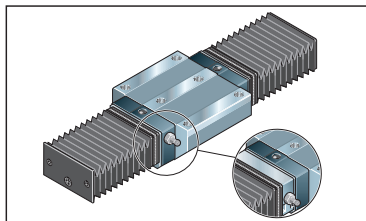

Scraper Plate

R1820 .1. 3. / 1810 291 40

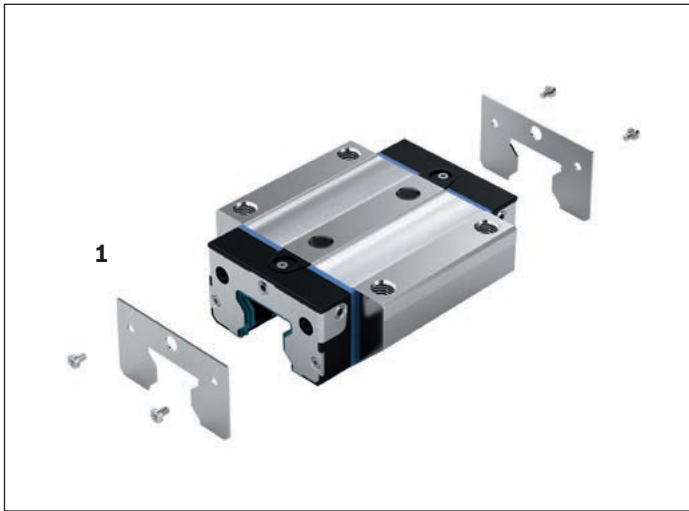

For mounting on runner blocks for guide rails with cover strip

1 Scraper plate

- Material: stainless spring steel to EN 10088
- Version: bright

Mounting instructions

When mounting the scraper plate, make sure there is a uniform gap between the guide rail and the scraper.

For lubricating from the end face:

Use special lube nipple or adapter (see "Accessories").

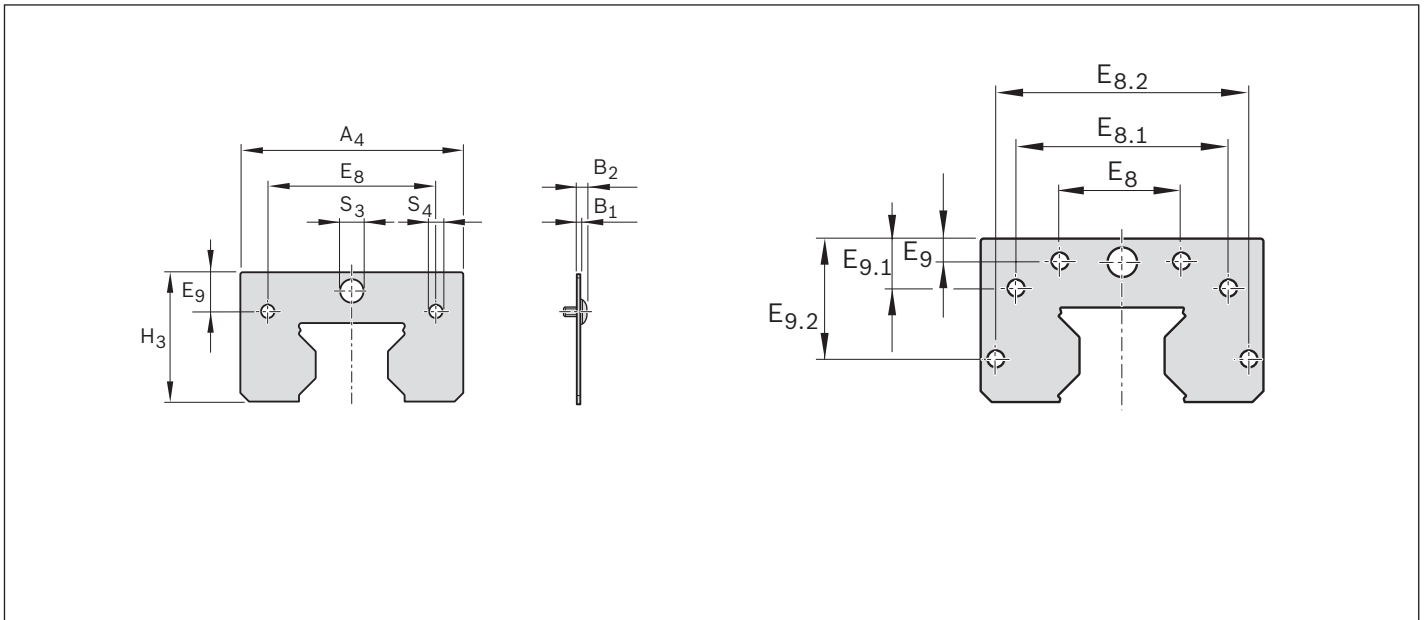

Part numbers and dimensions

Size	Part numbers	Dimensions (mm)											Mass (g)	
		A ₄	H ₃	B ₁	B ₂	E ₈	E _{8.1}	E _{8.2}	E ₉	E _{9.1}	E _{9.2}	S ₃		S ₄
25 ^{*)}	R1820 210 30	45.40	29.15	1.00	3.00	33.40	-	-	7.45	-	-	∅ 7.00	∅ 4.00	7
30 ^{*)}	R1820 710 30	58.40	35.70	1.00	3.00	43.00	-	-	11.20	-	-	∅ 7.00	∅ 4.00	11
35	R1820 310 30	67.40	39.70	1.00	3.00	50.30	-	-	12.05	-	-	∅ 7.00	∅ 4.00	15
45	R1820 410 30	80.40	49.70	2.00	5.10	62.90	-	-	15.70	-	-	∅ 7.00	∅ 5.00	44
55	R1820 510 30	92.80	56.70	2.00	5.80	74.20	-	-	17.80	-	-	∅ 7.00	∅ 6.00	52
65 ^{*)}	R1820 610 30	118.40	73.90	2.00	5.10	35.00	93.00	-	8.00	24.70	-	∅ 7.00	∅ 5.00	104
100 ¹⁾	R1810 291 40	180.50	103.50	2.50	6.50	64.00	130.00	162.60	8.00	28.40	69.0	∅ 9.00	∅ 6.00	300

*) In preparation

1) Generation 1

FKM Seal

R1810 .2. 3.

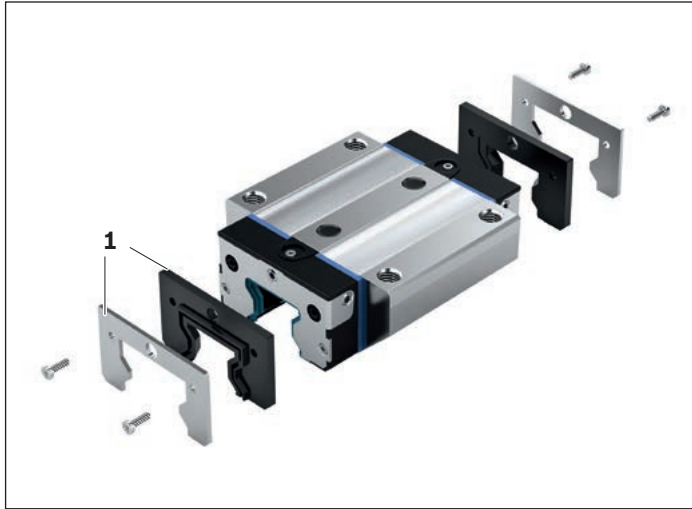

For mounting to the runner block

1 FKM seal, two-piece

- Material: stainless steel frame plus FKM seal

Special feature: Easy mounting and removal even when guide rail is screwed down. Follow the mounting instructions.

Mounting instructions

Comes complete with mounting screws.

Maximum tightening torque: 0.4 Nm

For lubricating from the end face: Use special lube nipple or adapter (see "Accessories").

Can be combined with an additional scraper plate. For sizes 35 to 65, use the FKM seal and scraper plate set (see next page).

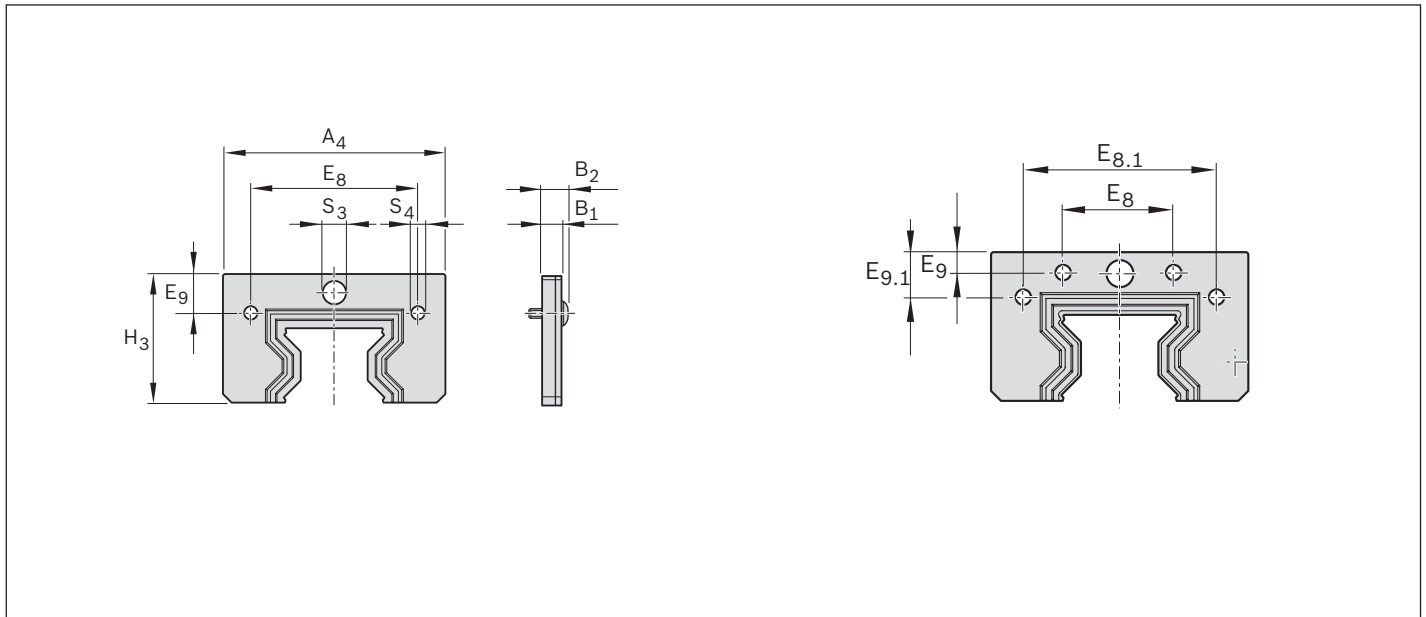

Part numbers and dimensions

Size	Part numbers	Dimensions (mm)										Mass (g)
		A ₄	H ₃	B ₁	B ₂	E ₈	E _{8.1}	E ₉	E _{9.1}	S ₃	S ₄	
25 ^{*)}	R1810 220 30	45.40	29.15	6.00	8.00	33.40	-	7.45	-	Ø 7.00	Ø 4.00	18
30 ^{*)}	R1810 720 30	58.40	35.70	6.00	8.00	43.00	-	11.20	-	Ø 7.00	Ø 4.00	30
35	R1810 320 30	67.40	39.70	6.00	8.00	50.30	-	12.05	-	Ø 7.00	Ø 4.00	40
45	R1810 420 30	80.40	49.70	6.00	9.10	62.90	-	15.70	-	Ø 7.00	Ø 5.00	62
55	R1810 520 30	92.80	56.70	6.00	9.80	74.20	-	17.80	-	Ø 7.00	Ø 6.00	76
65 ^{*)}	R1810 620 30	118.40	73.90	6.00	9.10	93.00	93.00	8.00	24.70	Ø 7.00	Ø 5.00	146

^{*)} In preparation

FKM Seal Set R1810 .2. 7.

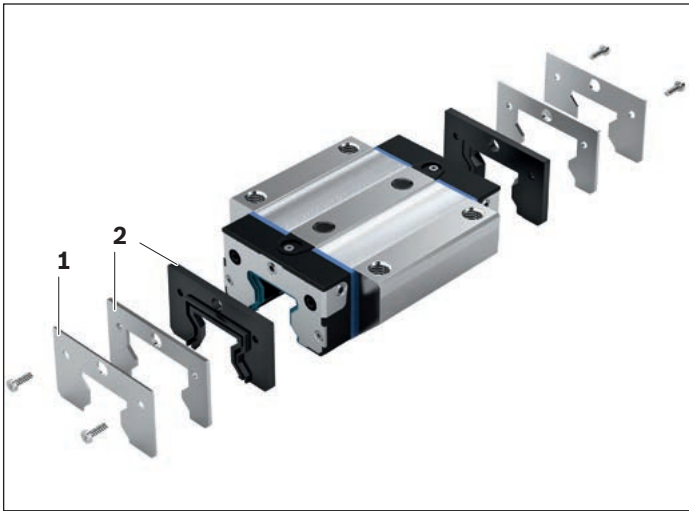

For mounting on runner block
FKM seal set with scraper plate:

- 1 Scraper plate
- 2 FKM seal, two-piece

Mounting instructions

Comes complete with mounting screws.

Maximum tightening torque: 0.4 Nm

For lubricating from the end face:

Use special lube nipple or adapter (see "Accessories").

Follow the mounting instructions.

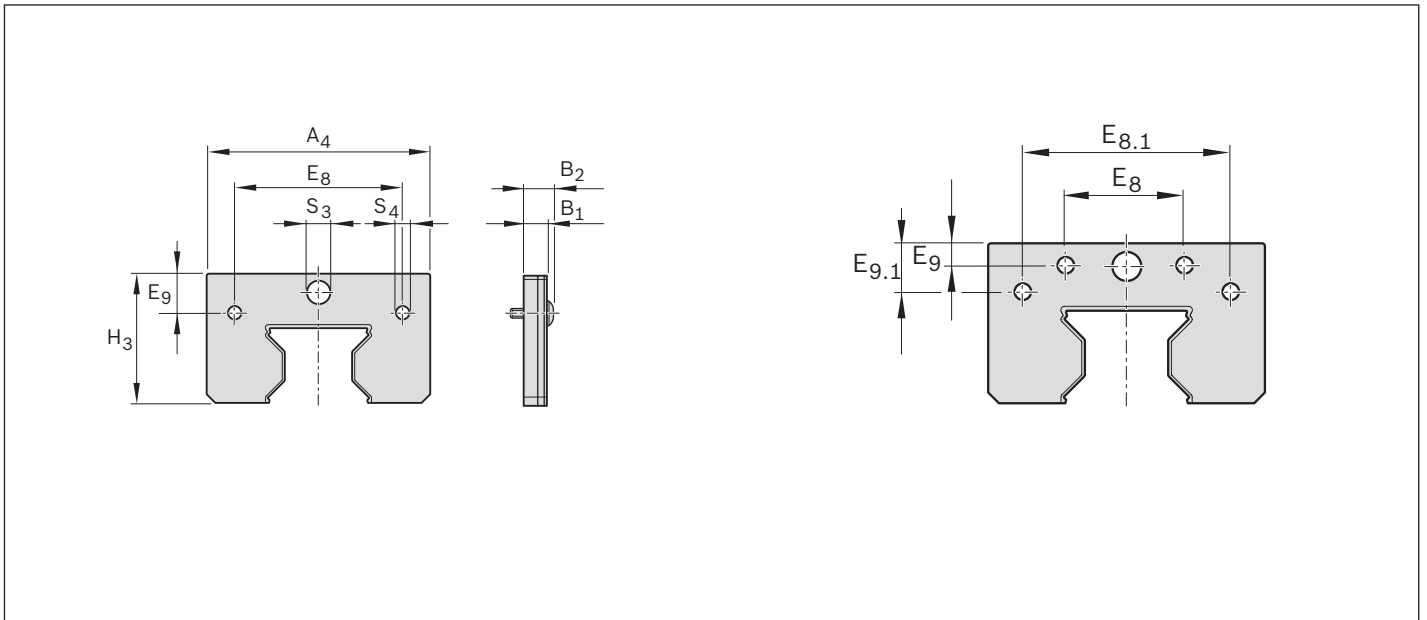

Part numbers and dimensions

Size	Part numbers	Dimensions (mm)										Mass (g)
		A ₄	H ₃	B ₁	B ₂	E ₈	E _{8.1}	E ₉	E _{9.1}	S ₃	S ₄	
25 ^{*)}	R1810 220 70	45.40	29.15	7.00	9.00	33.40	–	7.45	–	∅ 7.00	∅ 4.00	25
30 ^{*)}	R1810 720 70	58.40	35.70	7.00	9.00	43.00	–	11.20	–	∅ 7.00	∅ 4.00	42
35	R1810 320 70	67.40	39.70	7.00	9.00	50.30	–	12.05	–	∅ 7.00	∅ 4.00	55
45	R1810 420 70	80.40	49.70	8.00	11.10	62.90	–	15.70	–	∅ 7.00	∅ 5.00	106
55	R1810 520 70	92.80	56.70	8.00	11.80	74.20	–	17.80	–	∅ 7.00	∅ 6.00	128
65 ^{*)}	R1810 620 70	118.40	73.90	8.00	11.10	93.00	93.00	8.00	24.70	∅ 7.00	∅ 5.00	250

^{*)} In preparation

Front Lube Units

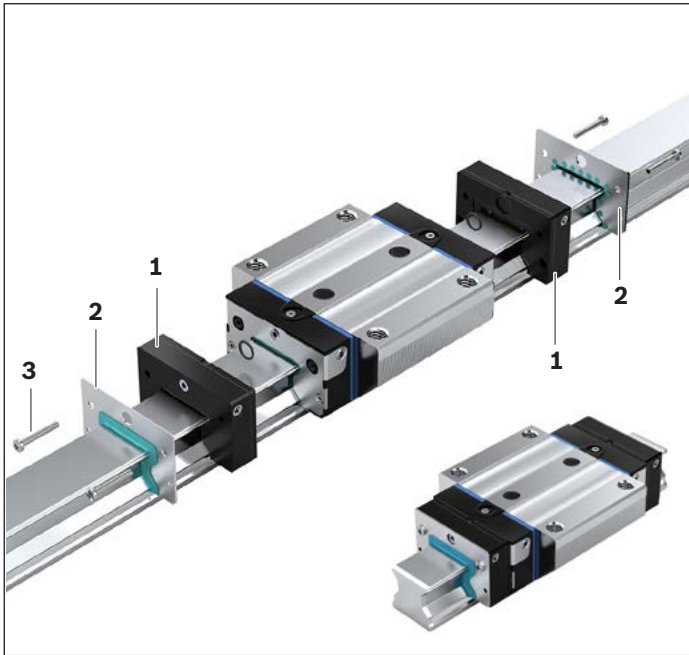

Advantages during mounting and service

- ▶ Up to 5,000 km travel without relubrication
- ▶ Only initial lubrication (with grease) of the roller runner block necessary
- ▶ Front lube units at both runner block ends
- ▶ Minimal lubricant loss
- ▶ Reduced oil consumption
- ▶ No lube lines
- ▶ Max. operating temperature 60 °C
- ▶ In-service refilling possible using lube nipple on end face or at side
- ▶ Size 25:
 - Lube port on end face of the front lube unit suitable for lubricating the roller runner block with grease.

⚠ Before mounting the front lube units, always lubricate the roller runner blocks first **using grease!** Please refer to the “Lubrication” section.

Mounting instructions for front lube units

Front lube units are supplied complete with coated screws and additional end seals.

1. Mount one front lube unit (1) on each end of the roller runner block!
2. Do not remove roller runner blocks from the rail!
3. Slide on the front lubrication units (1) and the end seals (2) and align them with the roller runner block.
4. Tighten screws (3) with tightening torque M_A (see Table).

Size	 Item 3	Tightening torque M_A (Nm)
25*)		
30*)		
35	M3 x 22	0.7
45	M4 x 25	1.0
55	M5 x 30	1.3
65	M4 x 30	1.0

*) in preparation

Notes

Front lube units for roller runner blocks are supplied complete with coated screws, additional end seals and lube nipple. Front lube units are supplied ready-filled with oil (Mobil SHC 639) and can be mounted immediately after initial lubrication of the roller runner block.

Lubricant distribution

Specially designed lube distribution ducts ensure that the lubricant is applied only where needed: directly to the raceways and to the top face of the roller guide rails.

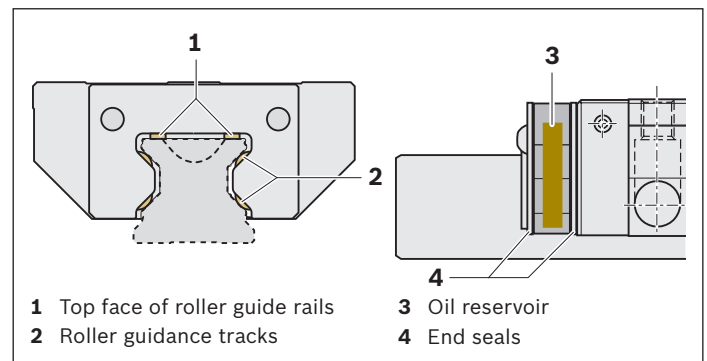

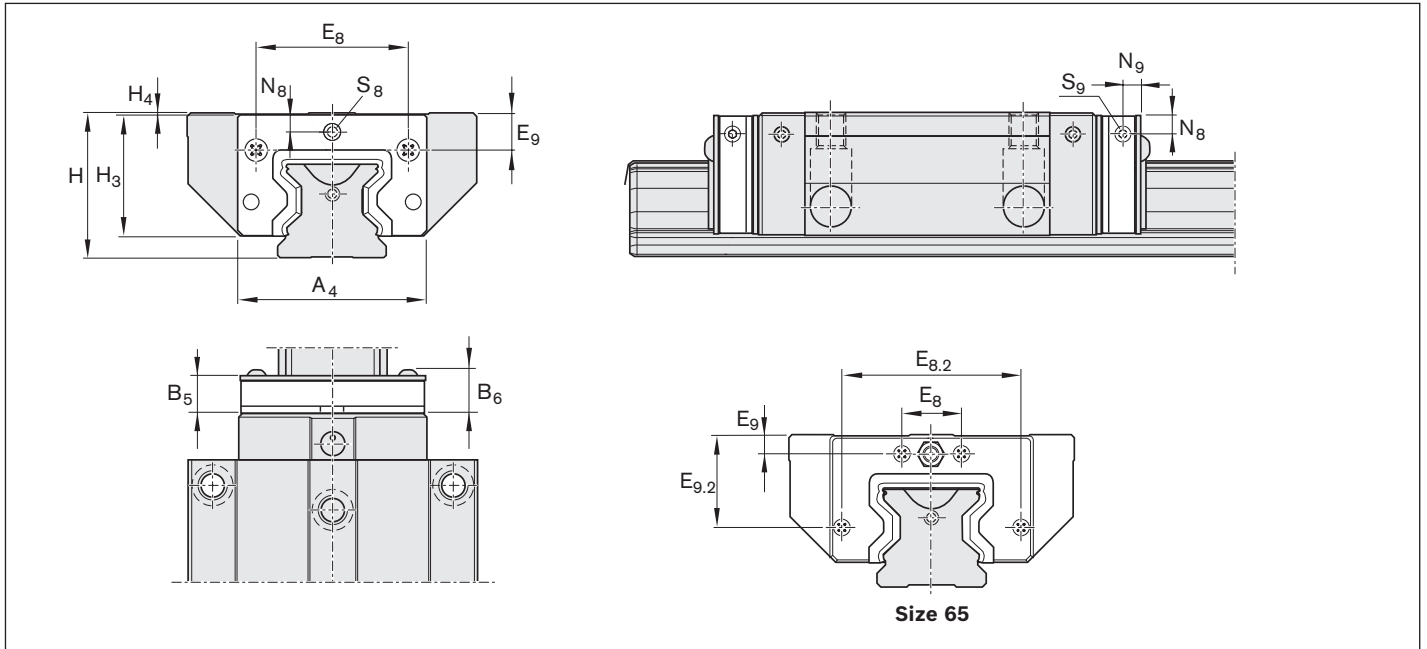
Dimensions and technical data

Size 65

Size	Part numbers	Dimensions (mm)														Oil (cm ³)	Mass (g)
		A ₄	B ₅	B ₆	E ₈	E _{8.2}	E ₉	E _{9.2}	H	H ₃	H ₄	N ₈	N ₉	S ₈	S ₉		
25 ^{*)}	R1810 225 00	44.0	13.0	15.5	33.4	-	8.40 ¹⁾ 12.40 ²⁾	-	36 ¹⁾ 40 ²⁾	29.2	0.50 ¹⁾ 4.50 ²⁾	5.00 ¹⁾ 9.00 ²⁾	-	M6	-	2.6	24
30 ^{*)}	R1810 725 00	59.0	14.5	17.0	43.0	-	12.0 ¹⁾ 12.40 ²⁾	-	42 ¹⁾ 45 ²⁾	36.0	0.40 ¹⁾ 3.50 ²⁾	6.00 ¹⁾ 9.00 ²⁾	5.0	M6	M6	5.2	34
35	R1810 325 00	64.0	16.5	19.0	50.3	-	13.10 ¹⁾ 20.10 ²⁾	-	48 ¹⁾ 55 ²⁾	40.0	0.75 ¹⁾ 7.75 ²⁾	6.25 ¹⁾ 13.25 ²⁾	5.5	M6	M6	8.3	46
45	R1810 425 00	78.0	18.5	21.8	62.9	-	16.70 ¹⁾ 26.75 ²⁾	-	60 ¹⁾ 70 ²⁾	50.0	0.75 ¹⁾ 10.75 ²⁾	7.25 ¹⁾ 17.25 ²⁾	7.5	M6	M6	13.8	88
55	R1810 525 00	91.5	20.3	24.3	74.2	-	18.85 ¹⁾ 28.95 ²⁾	-	70 ¹⁾ 80 ²⁾	56.3	0.75 ¹⁾ 10.75 ²⁾	8.25 ¹⁾ 18.25 ²⁾	9.0	M6	M6	22.8	122
65	R1810 625 00	119.0	21.0	24.3	35.0	106	9.30	55.0	90	74.8	0.75	8.55	8.5	M6	M6	47.6	225

*) in preparation

1) Dimension referred to the roller runner block mounting face on standard height version

2) Dimension referred to the roller runner block mounting face on high version

Front Lube Units

In-service lubrication intervals for roller runner blocks with front lube units

- ▶ Check the front lubrication units when the system has covered the travel distance specified Fig. 1.

We recommend replacing the front lube units when the specified travel according to Fig. 4 has been reached or, at the latest, after 2 years. Before mounting the new front lube units, the roller runner block has to be relubricated with grease. In clean operating environments, the roller runner blocks can be relubricated (sizes 35 to 65 from the side and size 25 from the end) with grease (Dynalub 510) (see Table).

- ⚠ If other types of lubricants are used, this may lead to a reduction in the relubrication intervals, the achievable travel in short-stroke applications, and the load capacities. Possible chemical interactions between the plastic materials, lubricants and preservative oils must also be taken into account.
- ⚠ The recommended in-service lubrication intervals depend on environmental factors, load and type of loading. Ambient conditions include: swarf, metallic and other abrasion, solvents and temperature. Load types include vibrations, impacts and tilting.
- ⚠ The service conditions are unknown to the manufacturer. Users can only determine the in-service lubrication intervals with certainty by conducting their own in-house tests or by close observation.
- ⚠ Do not allow the roller guide rails or roller runner blocks to come into contact with water-based metalworking fluids!

Table 1

Size	Relubrication (cm ³)
25	0.8
30 ^{*)}	
35	0.9
45	1.0
55	1.4
65	2.7

*) Values in preparation

Load-dependent relubrication intervals for roller runner blocks with front lube units Sizes 25 to 65**The following conditions apply:**

- ▶ Lubricants for roller runner blocks:
Dynalub 510 (NLGI 2 grease), or alternatively Castrol Longtime PD 2 (NLGI 2 grease)
- ▶ Lubricant for front lube units:
Mobil SHC 639 (synthetic oil)
- ▶ Maximum speed: $v_{\max} = 2 \text{ m/s}$
- ▶ No exposure to metalworking fluids
- ▶ Standard seals
- ▶ Ambient temperature: $T = 10 - 40 \text{ }^\circ\text{C}$

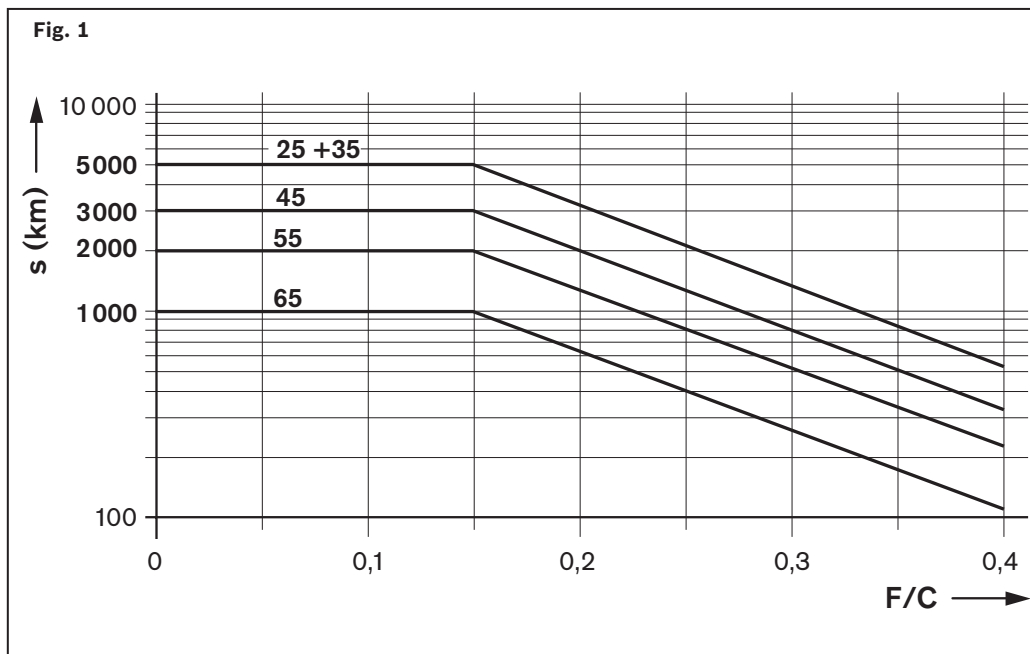
**Note**

The load ratio F/C is the quotient of the equivalent dynamic load on the bearing F (making allowance for the preload $C2$ or $C3$) divided by the dynamic load capacity C (see "General Technical Data and Calculations").

Key to graphs

s	= relubrication interval expressed as travel	(km)
C	= dynamic load capacity	(N)
F	= equivalent dynamic load	(N)

Bellows

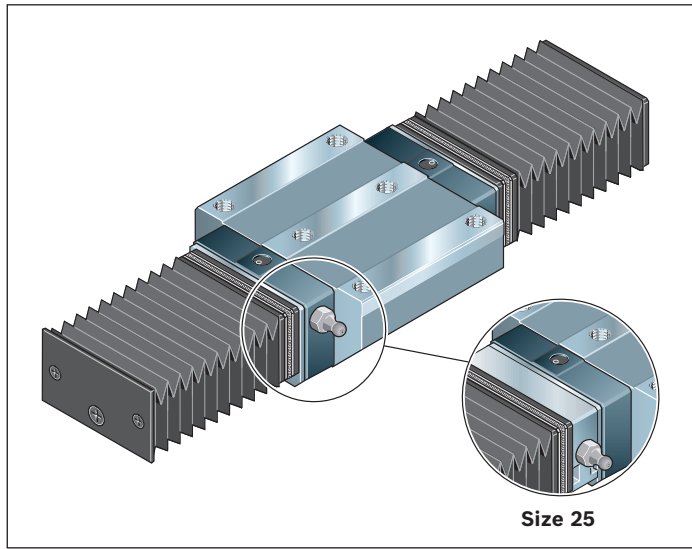

Bellows

- ▶ Material: Polyurethane-coated polyester fabric
- ▶ Size 25: Aluminum lube plate. The runner block lube nipple can be used.

Heat resistant bellows

- ▶ Material: Nomex fabric, metallized

Temperature resistance

- ▶ Non combustible, non flammable
- ▶ Resistant to individual sparks, welding spatter and hot chips
- ▶ Peak temperatures of up to 200 °C near the protective metal coat possible
- ▶ Operating temperature for the entire bellows: 100 °C

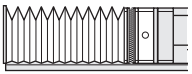
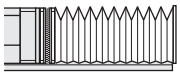
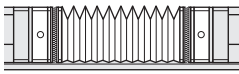
Size						
	Part number, no. of folds	Mass	Part number, no. of folds	Mass	Part number, no. of folds	Mass
	Bellows		Bellows		Bellows	
25	R1820 201 00, ...	on request	R1820 202 00, ...	on request	R1820 203 00, ...	on request
30^{*)}						
35	–	–	R1820 302 00, ...		–	–
45	–	–	R1820 402 00, ...		–	–
55	–	–	R1820 502 00, ...		–	–
65	–	–	R1820 602 00, ...		–	–
	Heat resistant bellows		Heat resistant bellows		Heat resistant bellows	
25	R1820 251 00, ...	on request	R1820 252 00, ...	on request	R1820 253 00, ...	on request
30^{*)}						
35	–	–	R1820 352 00, ...		–	–
45	–	–	R1820 452 00, ...		–	–
55	–	–	R1820 552 00, ...		–	–
65	–	–	R1820 652 00, ...		–	–

^{*)} In preparation

Ordering examples

Bellows

- ▶ Size 35, type 2
- ▶ number of folds: 36

Ordering data

Part number, no. of folds: R1820 302 00, 36 folds

Heat resistant bellows

- ▶ Size 35, type 2
- ▶ number of folds: 36

Ordering data

Part number, no. of folds: R1820 352 00, 36 folds

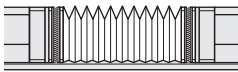
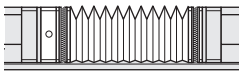
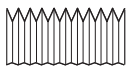
Size						
	Type 4: with 2 mounting frames		Type 5: with lube plate and mounting frame		Type 9: loose supply (spare part)	
	Part number, no. of folds	Mass	Part number, no. of folds	Mass	Part number, no. of folds	Mass
	Bellows		Bellows		Bellows	
25	R1820 204 00, ...	on request	R1820 205 00	on request	R1600 209 00	on request
30^{*)}						
35	R1820 304 00, ...		–	–	R1600 309 00	
45	R1820 404 00, ...		–	–	R1600 409 00	
55	R1820 504 00, ...		–	–	R1600 509 00	
65	R1820 604 00, ...		–	–	R1600 609 00	
	Heat resistant bellows		Heat resistant bellows		Heat resistant bellows	
25	R1820 254 00, ...	on request	R1820 255 00	on request	R1600 259 00	on request
30^{*)}						
35	R1820 354 00, ...		–	–	R1600 359 00	
45	R1820 454 00, ...		–	–	R1600 459 00	
55	R1820 554 00, ...		–	–	R1600 559 00	
65	R1820 654 00, ...		–	–	R1600 659 00	

*) In preparation

Bellows

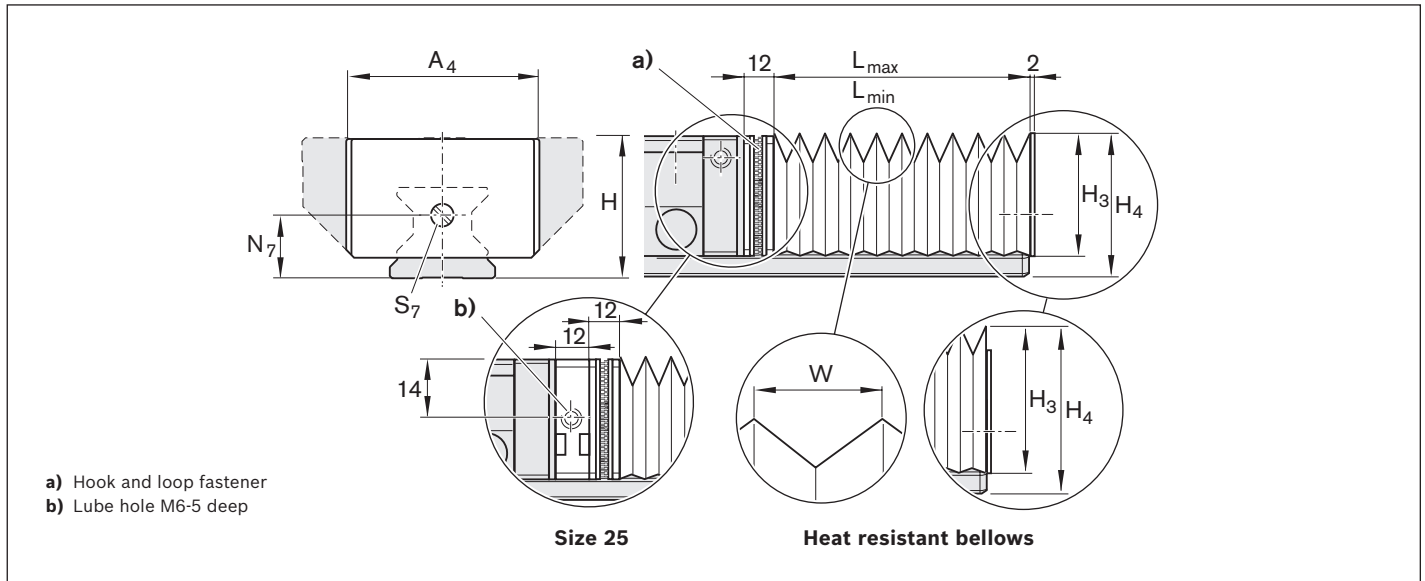

Size	Dimensions of bellows (mm)							Factor	
	A ₄	H	H ₃	H ₄	N ₇	S ₇	W	U	
25	45	36	28.5	35.0	15	M4	12.9	1.32	
30^{*)}									
35	64	48	39.0	47.0	22	M4	19.9	1.18	
45	83	60	49.0	59.0	30	M4	26.9	1.13	
55	96	70	56.0	69.0	30	M4	29.9	1.12	
65	120	90	75.0	89.0	40	M4	40.4	1.08	

Size	Dimensions of heat resistant bellows (mm)							Factor	
	A ₄	H	H ₃	H ₄	N ₇	S ₇	W	U	
25	62	36	39.0	44.5	15	M4	25.9	1.25	
30^{*)}									
35	74	48	46.0	54.0	22	M4	29.9	1.21	
45	88	60	54.0	64.0	30	M4	32.9	1.18	
55	102	70	62.0	75.0	30	M4	37.9	1.16	
65	134	90	86.0	99.0	40	M4	52.4	1.11	

*) In preparation

Notes for mounting the bellows

The bellows are delivered preassembled. Comes complete with mounting screws. The runner block lube nipple can be used.

In types 1 and 2, a tapped hole size M4, 10 mm deep and countersunk 2 x 45°, must be drilled into each end face of the rail.

See "Mounting instructions for bellows" for mounting.

Calculation of the bellows

$L_{\max} = (\text{Stroke} + 30) \cdot U$ $L_{\min} = L_{\max} - \text{stroke}$ $\text{Number of folds} = \frac{L_{\max}}{W} + 2$	L_{\max} = bellows extended (mm) L_{\min} = bellows compressed (mm) Stroke = stroke (mm) U = calculation factor W = maximum extension (mm)
---	--

Calculation of the rail length

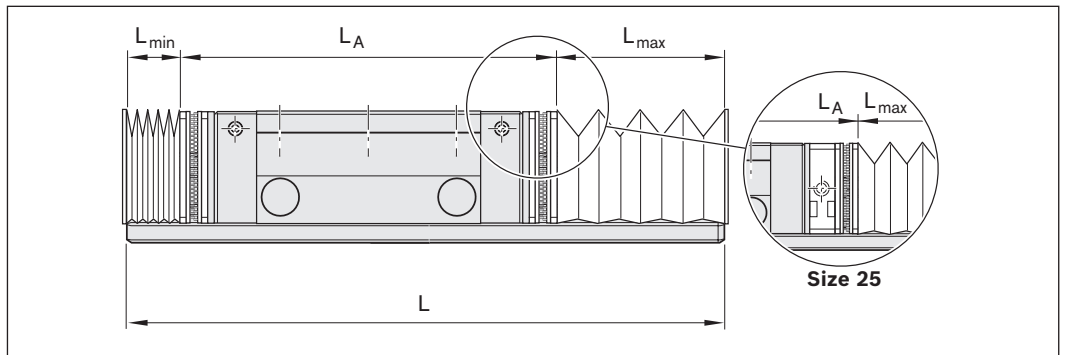

$L = L_{\min} + L_{\max} + L_A$	L = rail length (mm) L_A = length of roller runner block with mounting frame (mm)
---------------------------------	--

Bellows

Mounting instructions for bellows

a) Mounting the bellows to the roller runner block (types 2 and 4), including mounting at the rail end (types 2 and 1)

Types 1 and 2 only:

1. Before mounting the bellows, drill and tap a hole in the end face of the roller guide rail (5), see dimensions N_7 and S_7 in the table and diagram alongside “Mounting instructions” on the previous page.

Types 2 and 4:

1. If there is a lube nipple in the front lube hole (1), remove it and screw it into a lateral lube hole (relubrication side) (3).
2. Use a set screw (2) to plug the open lube hole.
3. Remove the upper mounting screws from the scraper plate.

4. Screw the mounting frame (with hook and loop fastener (4)) to the roller runner block using the screws supplied along with the bellows.
5. Push on the bellows.

Types 1 and 2 only:

1. Once the bellows are installed, screw them tight to the end of the rail (5).

b) Size 25 only: mounting the lubrication plate and the bellows (types 1, 3 and 5)

Notes

In size 25, the lube port is hidden by the bellows. Consequently, a lubrication plate has to be fitted to at least one end of a roller runner block for in-service lubrication. The lubrication plate can be turned around,

thus allowing lubrication from the preferred side.

1. Remove the lube nipple (1) or set screw (2) from the lube hole on the roller runner block (relubrication side).
2. Screw the lube nipple (3) into the side of the lube plate (6).
3. Insert the O-ring (7) into the recess.
4. Screw the lube plate (6) and the mounting frame (4) to the roller runner block.
5. Plug the unused lube hole with a set screw.

⚠ Set screws must lie flush with the outer surface of the lube plate!

For all types:

hook and loop fastener for the mounting frame (4)

Closing the hook and loop fastener:

1. Position one edge of the hook and loop fastener part on the bellows side (8) against the mating part on the mounting frame side (4).
2. Make sure the two parts are properly positioned!
3. Press the bellows firmly up against the mounting frame!

Opening the hook and loop fastener:

4. Using a flat tool, start at one side (preferably a corner).
5. Carefully lever the two halves apart.

⚠ Be careful not to shear off the hooks and loops!

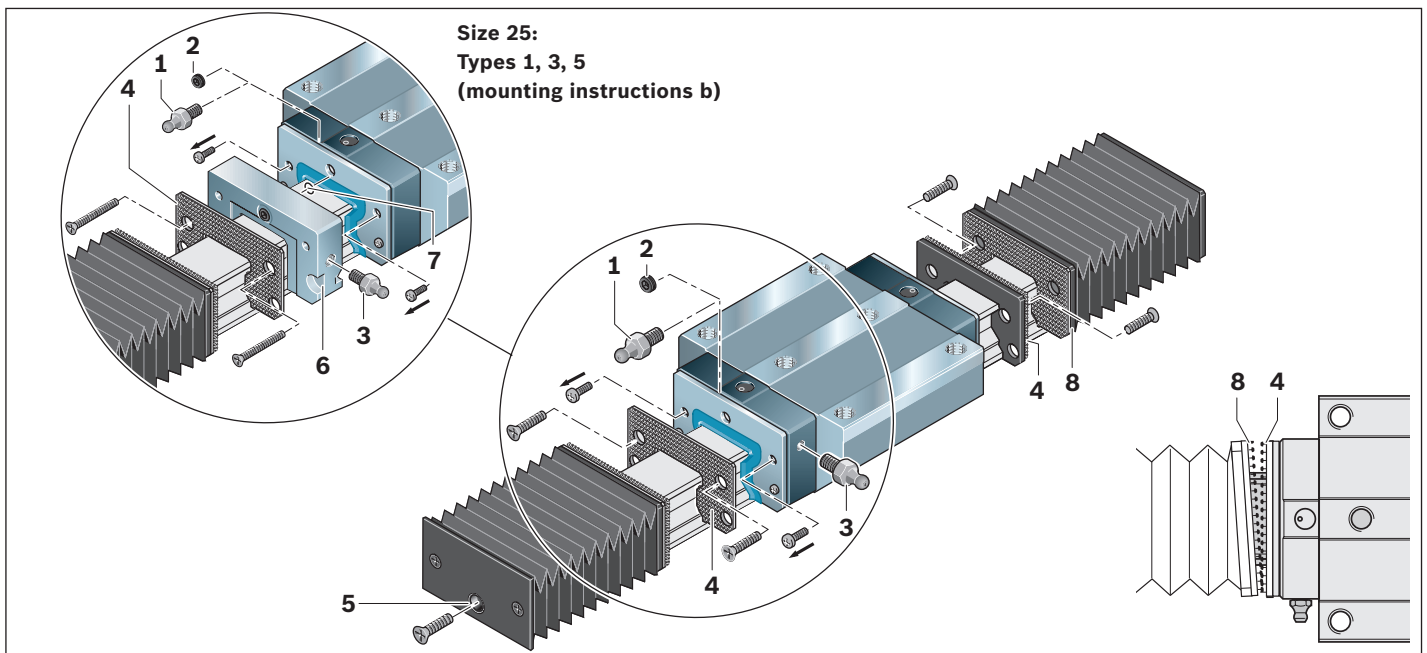

Lube Connections

Hydraulic type lube nipple

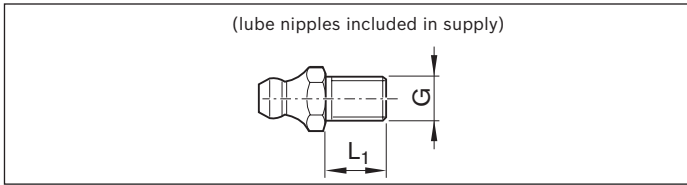

Part numbers	Dimensions (mm)		Mass (g)
	G	L ₁	
R3417 008 02	M6	8	2.6
R3417 014 02	M8x1	10	4.5

Hydraulic type lube nipple 45°

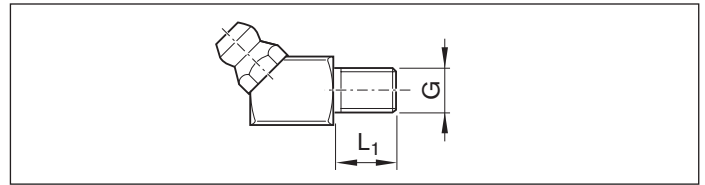

Part numbers	Dimensions (mm)		Mass (g)
	G	L ₁	
R3417 007 02	M6	8	7.4

Hydraulic type lube nipple 30°

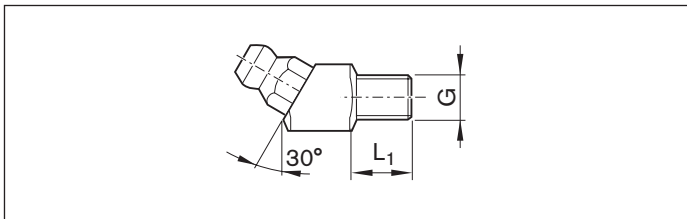

Part numbers	Dimensions (mm)		Mass (g)
	G	L ₁	
R3417 023 02	M6	8	7.4

Reducer M6

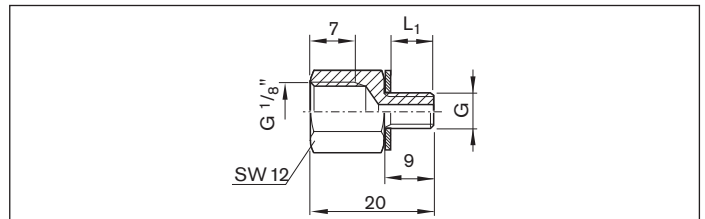

Part numbers	Dimensions (mm)		Mass (g)
	G	L ₁	
R3455 032 04	M6	8	7.5

Reducer M8 x 1

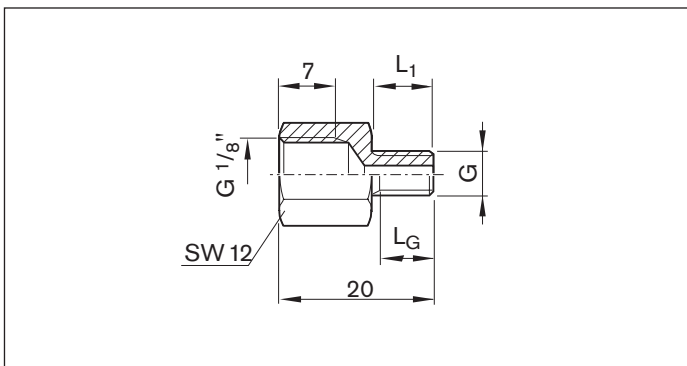

Part numbers	Dimensions (mm)			Mass (g)
	G	L ₁	L _G	
R3455 030 51	M8x1	8	6.5	8.6

Extension pieces

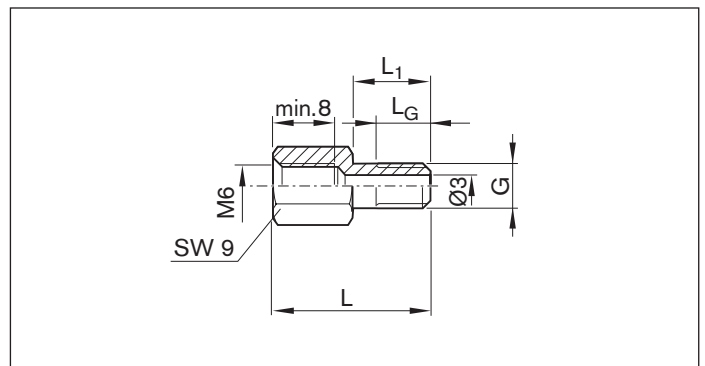

Part numbers	Dimensions (mm)				Mass (g)
	G	L	L ₁	L _G	
R3455 033 04 ¹⁾	M6	19.5	9.0	7.5	5.0
R3455 034 04 ²⁾	M6	20.5	10.0	8.0	5.5
R3455 035 04 ³⁾	M6	24.5	14.0	8.0	5.5
R3455 036 04 ⁴⁾	M6	25.5	15.0	8.0	6.0
R3455 037 04 ⁵⁾	M6	26.5	16.0	8.0	6.0

- 1) With scraper plate sizes 25 to 35
- 2) With scraper plate sizes 45 to 65
- 3) With FKM seal sizes 25 to 65
- 4) With FKM seal set sizes 25 to 35
- 5) With FKM seal set sizes 45 to 65

Lube Connections

Connectors

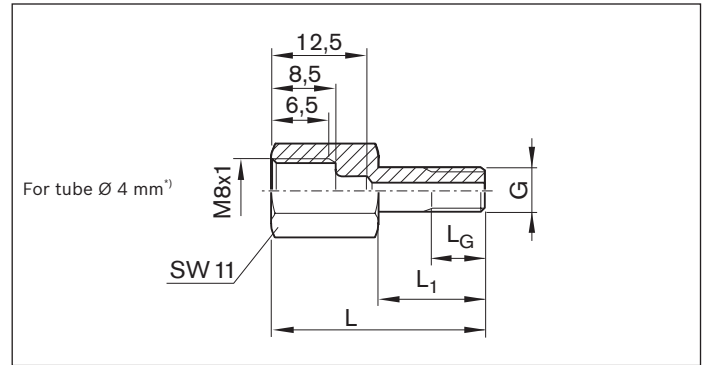
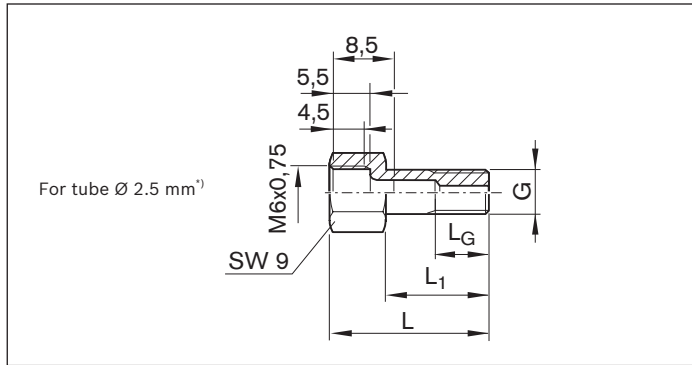

Part numbers	Dimensions (mm)				Mass (g)
	G	L	L ₁	L _G	
R3455 030 38 ¹⁾	M6	15.5	8.0	6.5	4.0
R3455 038 04 ²⁾	M6	16.5	9.0	7.5	5.0
R3455 039 04 ³⁾	M6	17.5	10.0	8.0	5.5
R3455 040 04 ⁴⁾	M6	21.5	14.0	8.0	5.5
R3455 041 04 ⁵⁾	M6	22.5	15.0	8.0	6.0
R3455 042 04 ⁶⁾	M6	23.5	16.0	8.0	6.0

Part numbers	Dimensions (mm)				Mass (g)
	G	L	L ₁	L _G	
R3455 030 37 ¹⁾	M6	22.0	8.0	6.5	9.0
R3455 043 04 ²⁾	M6	23.0	9.0	7.5	9.5
R3455 044 04 ³⁾	M6	24.0	10.0	8.0	10.0
R3455 045 04 ⁴⁾	M6	28.0	14.0	8.0	10.5
R3455 046 04 ⁵⁾	M6	29.0	15.0	8.0	10.5
R3455 030 52 ⁶⁾	M6	30.0	16.0	8.0	11.0

Swivel fittings

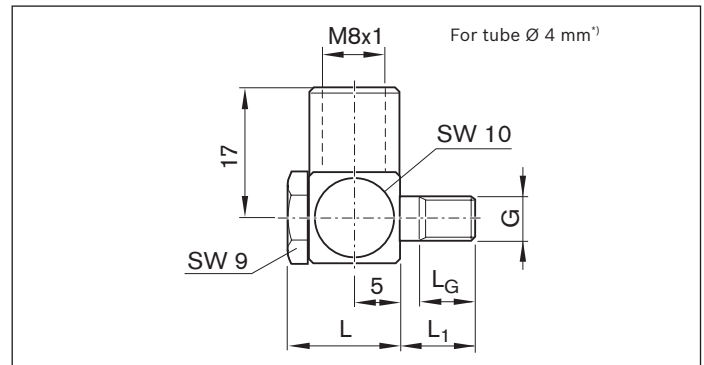
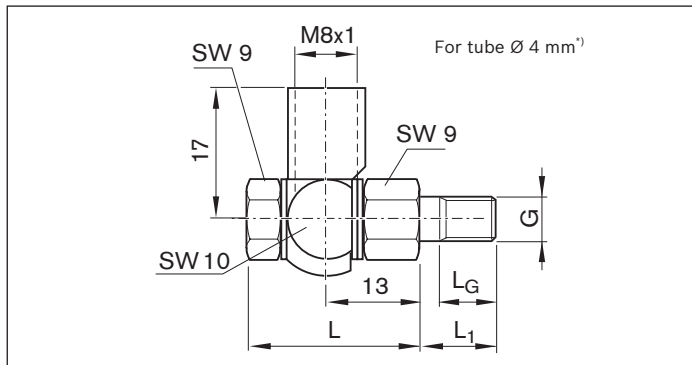

Part numbers	Dimensions (mm)				Mass (g)
	G	L	L ₁	L _G	
R3417 018 09 ¹⁾	M6	22	8.0	6.5	17.0
R3417 059 09 ²⁾	M6	22	9.0	7.5	17.0
R3417 060 09 ³⁾	M6	22	10.0	8.0	17.5
R3417 061 09 ⁴⁾	M6	22	14.0	8.0	19.0
R3417 062 09 ⁵⁾	M6	22	15.0	8.0	19.5
R3417 063 09 ⁶⁾	M6	22	16.0	8.0	20.0

Part numbers	Dimensions (mm)				Mass (g)
	G	L	L ₁	L _G	
R3417 047 09 ¹⁾	M6	12	8.0	8.0	10.0
R3417 064 09 ²⁾	M6	12	9.0	7.5	10.0
R3417 065 09 ³⁾	M6	12	10.0	8.0	10.5
R3417 066 09 ⁴⁾	M6	12	14.0	8.0	10.5
R3417 067 09 ⁵⁾	M6	12	15.0	8.0	11.0
R3417 068 09 ⁶⁾	M6	12	18.0	8.0	12.0

- 1) Lube fitting at the side and end face (without connection elements)
- 2) With scraper plate sizes 25 to 35
- 3) With scraper plate sizes 35 to 65
- 4) With FKM seal sizes 25 to 65
- 5) With FKM seal set sizes 25 to 35
- 6) With FKM seal set sizes 45 to 65

^{*)} For connections as per DIN 3854 and DIN 3862 (solderless tube fittings)

Tube connectors
Tube materials

- ▶ Copper
- ▶ Brass
- ▶ PU
- ▶ Nylon

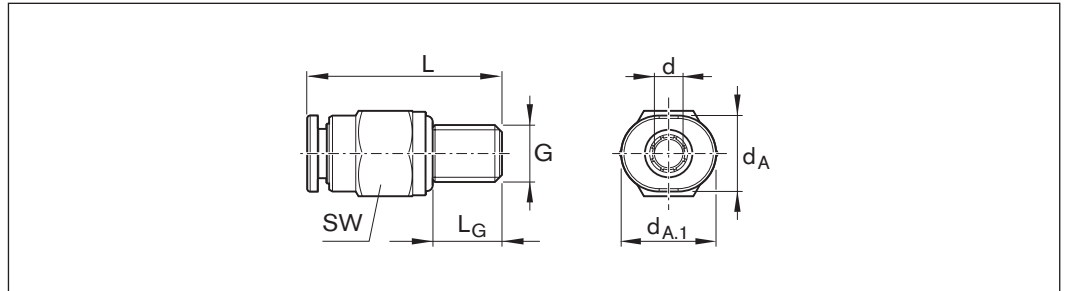
Straight connectors

Part numbers	Dimensions (mm)							Mass (g)
	d_A	$d_{A,1}$	$d^{1)}$	G	L	L_G	SW ³⁾	
R3417 035 09	8.5	10	4	M6	20.5	8	9	4.6
R3417 036 09	10.0	12	6	M6	21.5	8	10	4.8

1) Tube diameter

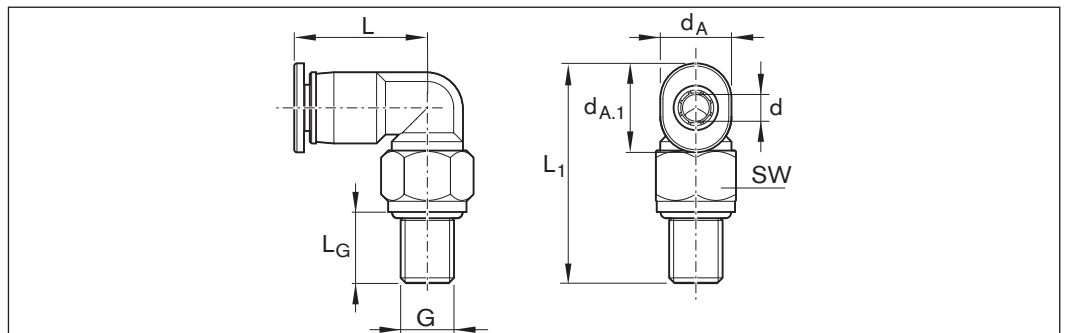
Angled socket connector, rotatable¹⁾

Part numbers	Dimensions (mm)							Mass (g)	
	d_A	$d_{A,1}$	$d^{2)}$	G	L	L_1	L_G		SW ³⁾
R3417 038 09	8.0	10	4	M6	14.95	24.7	8	9	5.1
R3417 039 09	10.5	12	6	M6	15.90	24.9	8	9	6.1

1) Maximum lubricating pressure: 30 bar (exerting slow pressure with manual grease gun)

2) Tube diameter

3) SW = WAF (width across flats)

O-rings

Part numbers	$d_1 \times d_2$ mm	Mass (g)
R3411 108 01	5 x 1.5	0.04
R3411 122 01	7 x 1.5	0.06
R3411 018 01	12 x 1.5	0.09
R3411 145 01	15 x 2.5	0.34

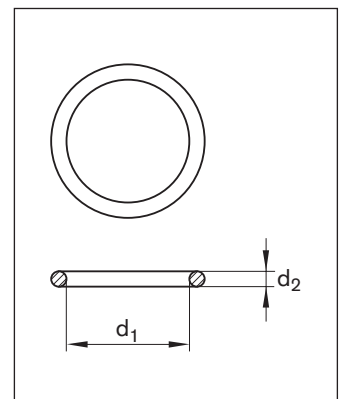

Overview of Accessories for Roller Guide Rails

Mounting runner block

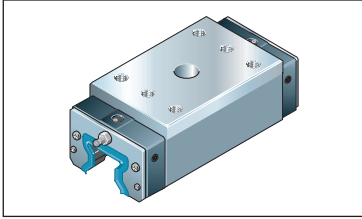

Plastic plugs



Cover strip



Steel plugs



Mounting tools for cover strip

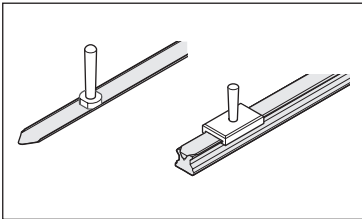

Mounting tool for steel plugs

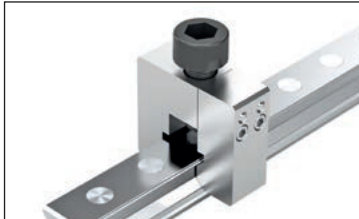

Protective end cap



Adjusting shafts

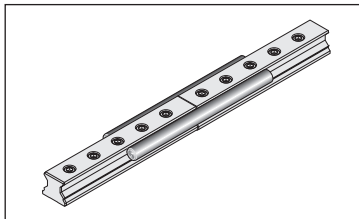

Strip clamp



Wedge profile

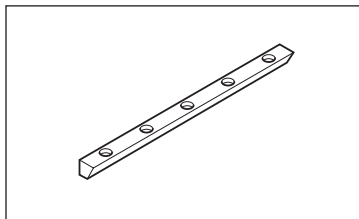

Mounting Runner Block

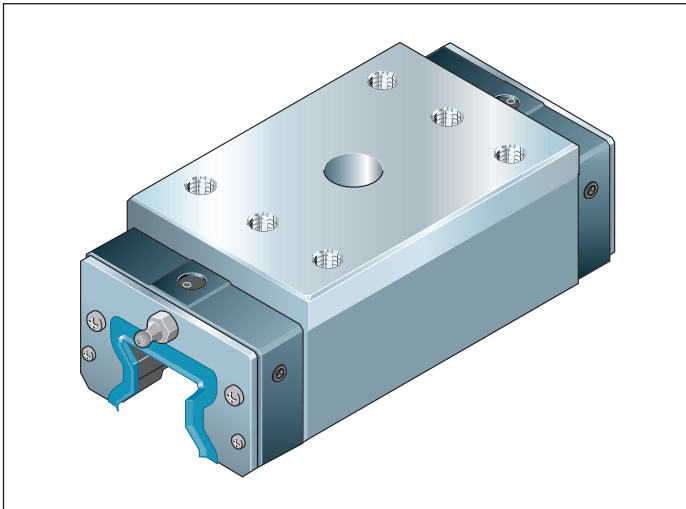

Mounting runner block SLH R1829 slimline, long, high

Mounting aid for parallel alignment of standard roller guide rails

Size	Part numbers for preload class C3
25	R1829 220 27
30 ^{*)}	
35	R1829 320 39
45	R1829 420 53
55	R1829 520 14
65	R1829 620 04

Mounting with mounting runner block

Note

Hole D serves both as key hole and screw hole. The central hole D in the mounting runner block allows precise measurement of the relative rail position. The rail mounting screws can also be driven down through this hole.

Aligning the rails

1. Align and mount the first roller guide rail using a graduated straightedge.
2. Set up a mounting bridge with dial gauge between the roller runner blocks.
3. Move both runner blocks in parallel until hole D in the mounting runner block is positioned precisely above a mounting hole in the rail.
4. Align the roller guide rail manually until the dial gauge shows the correct dimension.
5. Then screw down the roller guide rail through hole D in the mounting runner block.

Size	Dimensions ¹⁾ (mm)				Mass (kg)
	A	B ₁	B ₃	D	
25	48	81.5	115	19	0.8
30 ^{*)}					
35	70	103.6	145	25	1.9
45	86	134.0	183	27	4.0
55	100	162.1	216	27	6.0
65	126	194.0	264	30	11.8

^{*)} In preparation

1) For all other dimensions, see Roller Runner Blocks SLH R1824 ... 10

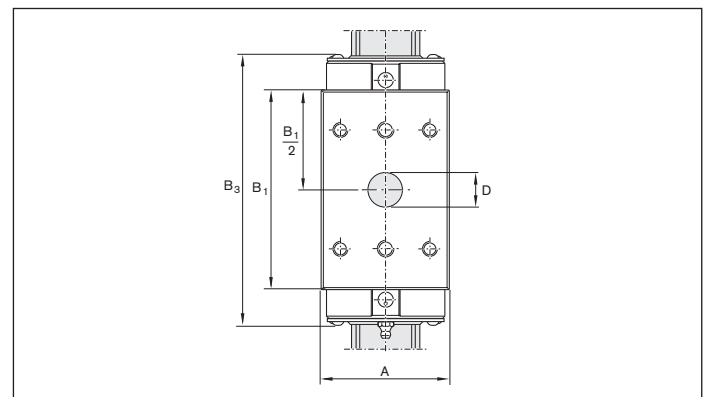
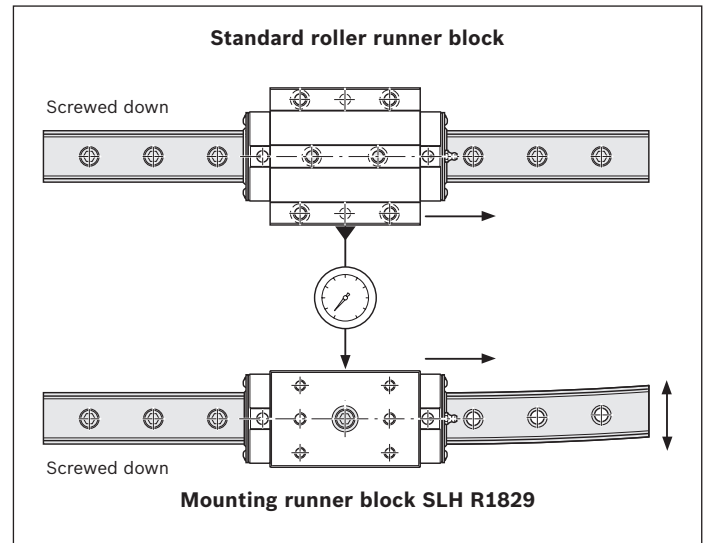

Cover Strip

Notes on cover strip

For detailed information, see “Mounting Instructions for the Cover Strip.”

Advantages

The cover strip is easy to clip on and remove.

- ▶ This considerably facilitates and speeds up the mounting process.
- ▶ The cover strip can be mounted and removed several times.

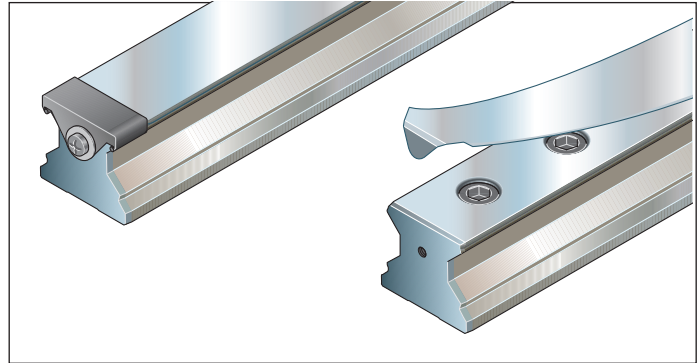

Versions and functions

A Snap-fit cover strip (standard)

- ▶ The cover strip is clipped on before the roller runner blocks are mounted and fits tightly.

B Sliding-fit cover strip

- ▶ For mounting or replacing a cover strip when the roller runner blocks or adjoining structure cannot be removed.
- ▶ A section of the snap-fit cover strip is very slightly widened and can then be easily slid under the roller runner blocks.

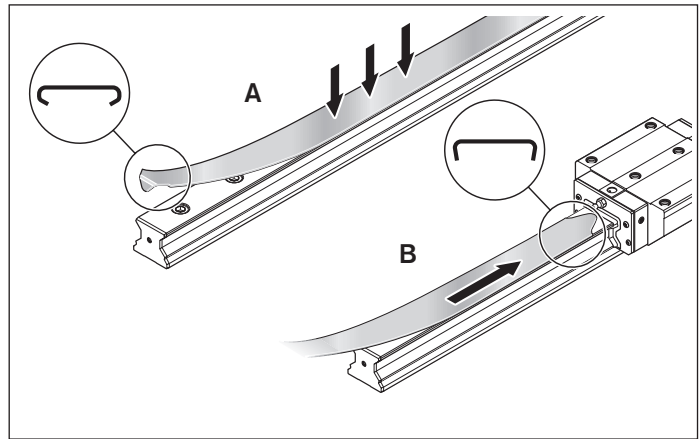

A special expanding tool can be used to create the sliding fit after a cover strip has been installed.

The main advantage is that the length L_s of the sliding fit can be optimized to suit the installation conditions. Please read the detailed mounting instructions!

For part numbers, see the following pages.

- ▲ The cover strip is a precision-machined part that must be handled with great care. It must on no account be bent.

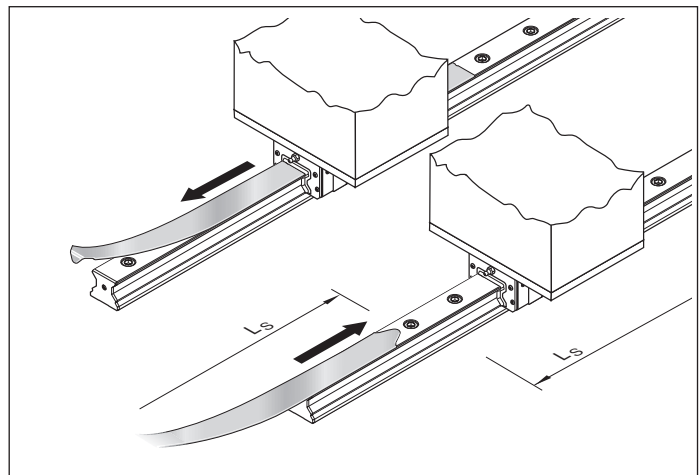

- ▲ Do not allow the roller runner blocks to travel right to the rail end!
The seals on the roller runner blocks could be damaged by the tapered edges of the cover strip.

- ▶ Maintain a minimum distance of L_{min} from the rail end.

Size	L (mm)
25-30	approx. 10.0
35-65	approx. 12.0
55/85	approx. 13.0
65/100	approx. 12.5
100	approx. 12.0
125	approx. 21.5

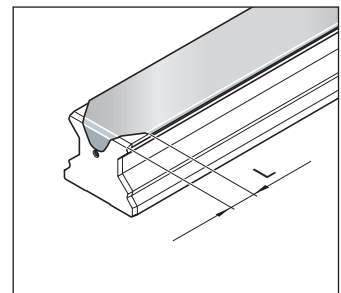

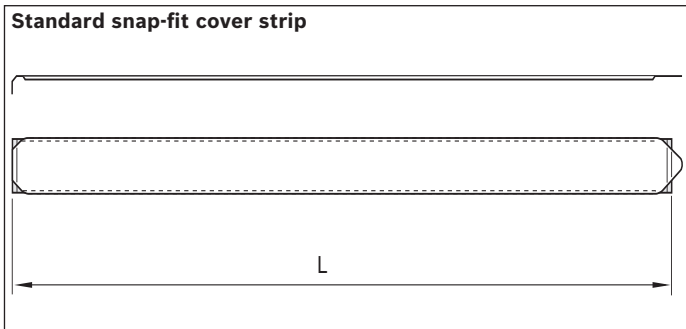

Size	Standard snap-fit cover strip Part number, length (mm)	Mass (g/m)
25	R1619 230 00, ...	32
30	R1619 730 00, ...	40
35	R1619 330 20, ...	80
45	R1619 430 20, ...	100
55	R1619 530 20, ...	120
65	R1619 630 20, ...	140
55/85	R1810 532 20, ...	190
65/100	R1810 632 20, ...	220
100	R1810 231 20, ...	200
125	R1810 331 20, ...	270

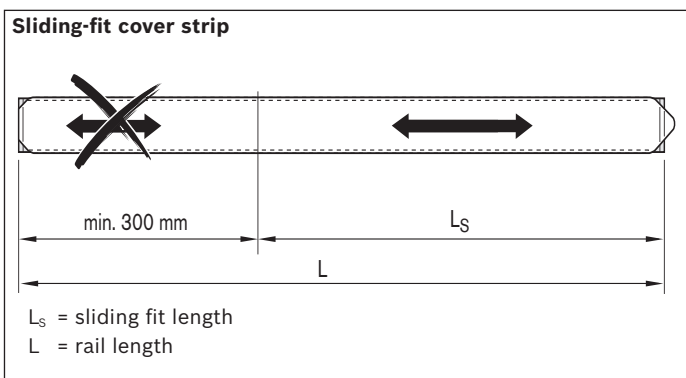

Size	Sliding-fit cover strip Part number, length (mm)	Mass (g/m)
25	R1619 230 10, ...	25
30	R1619 730 10, ...	40
35	R1619 330 30, ...	80
45	R1619 430 30, ...	100
55	R1619 530 30, ...	120
65	R1619 630 30, ...	140
55/85	R1810 532 30, ...	190
65/100	R1810 632 30, ...	220
100	R1810 231 30, ...	200
125	R1810 331 30, ...	270

Cover strip, separate

For initial mounting, as spare part or as replacement part

Note

A matching cover strip (sliding or snap fit) can be supplied for each roller guide rail length (see previous page).

Ordering example

Standard snap-fit cover strip

- ▶ Roller guide rail size 35
- ▶ Rail length $L = 2696$ mm

Ordering data

Part number, length L (mm)

R1619 330 20, 2696 mm

Ordering example

Sliding-fit cover strip

- ▶ Roller guide rail size 35
- ▶ Rail length $L = 2696$ mm
- ▶ Sliding fit length
 $L_s = 1200$ mm

Ordering data

Part number, length L (mm)

Sliding fit length L_s (mm)

R1619 330 30, 2696, 1200 mm

Detailed information about how to order and mount cover strips is contained in our “Mounting Instructions for the Cover Strip.”

Mounting Tools for Cover Strip

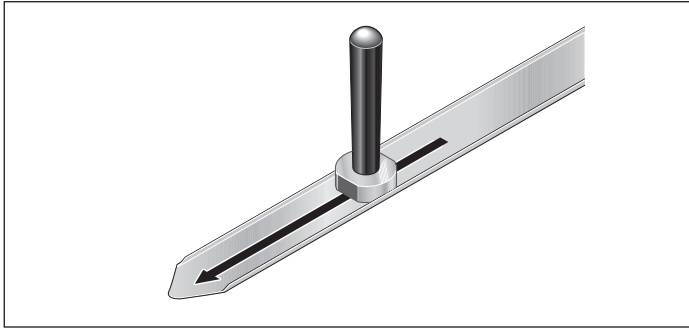

Expanding tool

For creating a sliding fit in the cover strip

Note

Detailed information about how to produce and mount sliding-fit cover strips is contained in our “Mounting Instructions for the Cover Strip.”

Size	Part numbers	Mass (kg)
25	R1619 215 10	0.08
30	R1619 715 10	0.10
35	R1619 315 30	0.10
45	R1619 415 30	0.13
55	R1619 515 30	0.21
65	R1619 615 30	0.27
55/85	R1810 592 30	on request
65/100	R1810 692 30	
100	R1810 291 30	
125	R1810 391 30	

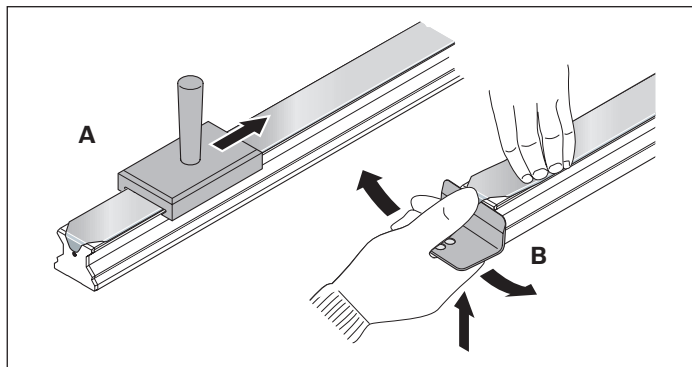

Cover strip mounting kit

Mounting tool and lifting plate

Notes

The kit comprises a mounting tool (A) for clipping on the cover strip and a lifting plate (B) for removing the cover strip.

For detailed information, see “Mounting Instructions for the Cover Strip.”

Size	Part numbers	Mass (kg)
25	R1619 210 70	0.17
30	R1619 710 50	0.20
35	R1619 310 50	0.21
45	R1619 410 50	0.20
55	R1619 510 50	0.21
65	R1619 610 50	0.28
55/85	R1810 592 53	on request
65/100	R1810 692 53	
100	R1810 291 53	
125	R1810 391 53	

Parts for Securing the Cover Strip

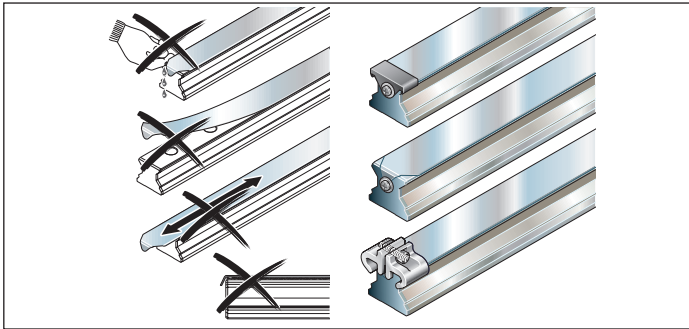

Parts for securing the cover strip

Rexroth recommends securing the cover strip with:

- ▶ Protective end caps
- ▶ Screws and washers
- ▶ Strip clamps (see the following page)

For other means of securing the cover strip, see “Mounting Instructions for the Cover Strip.”

Protective end caps

Size	Single plug		Bulk pack		Set (2 pieces per unit with screws)	
	Part numbers (without screws)	Mass (g)	Part number/quantity (without screws)	Mass (kg)	Part numbers (unit)	Mass (g)
25	R1619 239 00	1.0	R1619 239 01 / 1000	1.3	R1619 239 20	7
30	R1619 730 10	1.7	R1619 739 01 / 1000	1.7	R1619 739 20	8
35	R1619 339 10	2.0	R1619 339 01 / 1000	2.5	R1619 339 30	10
45	R1619 439 00	4.0	R1619 439 01 / 700	2.6	R1619 439 20	13
55	R1619 539 00	4.0	R1619 539 01 / 500	2.1	R1619 539 20	20
65	R1619 639 00	6.0	R1619 639 01 / 300	1.7	R1619 639 20	20

Screws and washers

Size	Screws (1200 pieces per unit)		Washers (1200 pieces per unit)	
	Part numbers (unit)	Mass (kg)	Part numbers (unit)	Mass (kg)
25	R3427 046 05	1.8	R3448 026 01	0.92
30	R3427 046 05	1.8	R3448 024 01	1.30
35	R3427 046 05	1.8	R3448 024 01	1.30
45	R3427 046 05	1.8	R3448 024 01	1.30
55	R3427 046 05	1.8	R3448 027 01	2.90
65	R3427 046 05	1.8	R3448 027 01	2.90
55/85	R3427 046 05	1.8	R3448 027 01	2.90
65/100	R3427 046 05	1.8	R3448 027 01	2.90
100	R3427 046 05	1.8	R3448 027 01	2.90
125	R3427 046 05	1.8	R3448 027 01	2.90

Parts for Securing the Cover Strip

Strip clamps

Size	Set (2 pieces per unit)		Bulk pack (100 pieces per unit)	
	Part numbers (unit)	Mass (g)	Part numbers (unit)	Mass (kg)
25	R1619 239 50	14	R1619 239 60	1.4
30	R1619 739 50	22	R1619 739 60	2.2
35	R1619 339 50	38	R1619 339 60	3.8
45	R1619 439 50	56	R1619 439 60	5.6
55	R1619 539 50	62	R1619 539 60	6.2
65	R1619 639 50	84	R1619 639 60	8.4

Plastic Mounting Hole Plugs

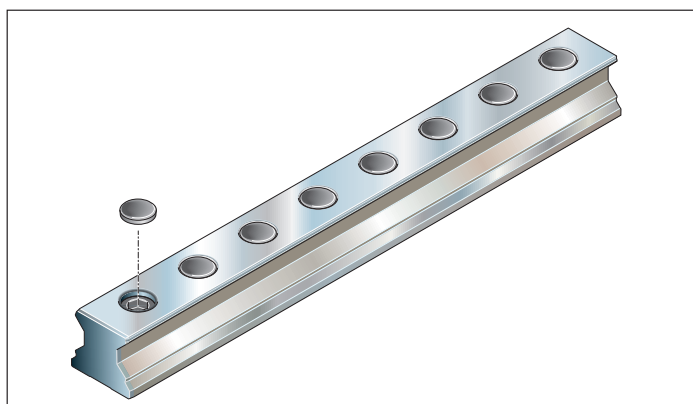

Notes for mounting

- For details on how to mount the plastic plugs, see “Mounting Instructions for Roller Rail Systems.”

Part numbers plastic plugs

Size	Single plastic cap		Bulk pack	
	Part numbers	Mass (g)	Part numbers/pieces	Mass/packing (kg)
25	R1605 200 80	0.3	R1605 200 80 / 5000	1.2
30/35	R1605 300 80	0.6	R1605 300 80 / 2000	1.2
45	R1605 400 80	1.0	R1605 400 80 / 1000	1.0
55	R1605 500 80	1.7	R1605 500 80 / 500	1.7
65	R1605 600 80	2.1	–	–

Steel Mounting Hole Plugs

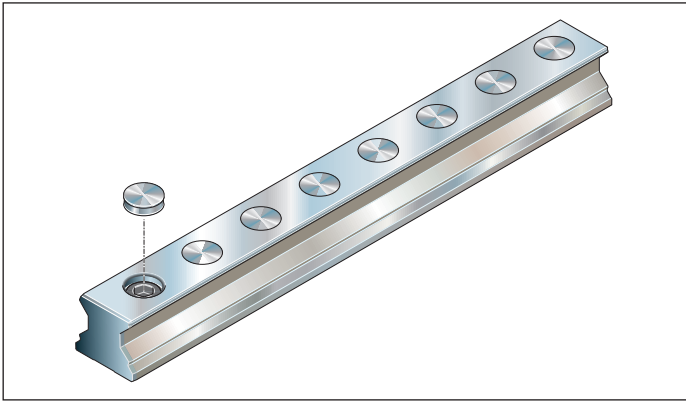

Notes

- ▶ Steel mounting hole plugs are not supplied with the roller guide rails.
- ▶ Order the mounting tool along with the plugs!
- ▶ For details on how to mount the steel plugs, see “Mounting Instructions for Roller Rail Systems.”

Part numbers steel plugs

Size	Single plug made of machining steel		Single plug, Resist NR II ¹⁾	
	Part numbers	Mass (g)	Part numbers	Mass (g)
25	R1606 200 75	2	–	–
30/35	R1606 300 75	3	R1606 300 78	3
45	R1606 400 75	6	R1606 400 78	6
55	R1606 500 75	8	R1606 500 78	8
65	R1606 600 75	9	R1606 600 78	9
100	R1836 200 75	23	–	–

1) Made from corrosion-resistant steel 1.4305

Mounting Tool for Steel Mounting Hole Plugs

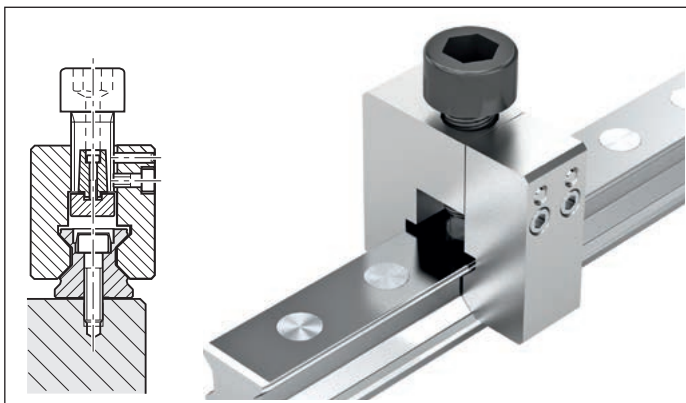

Note

- ▶ The two-piece mounting tool is suitable for mounting hole plugs to a screwed down roller guide rail (mounting instructions included).

Part numbers mounting tool

Size	Part numbers	Mass (kg)
25 ¹⁾	R1619 210 20	0.37
30 ¹⁾	R1619 710 30	0,37
35	R1619 310 30	0.57
45	R1619 410 30	0.85
55	R1619 510 30	1.50
65	R1619 610 30	1.85
100	R1810 251 30	2,80

*) In preparation

1) one-piece

Adjusting Shafts

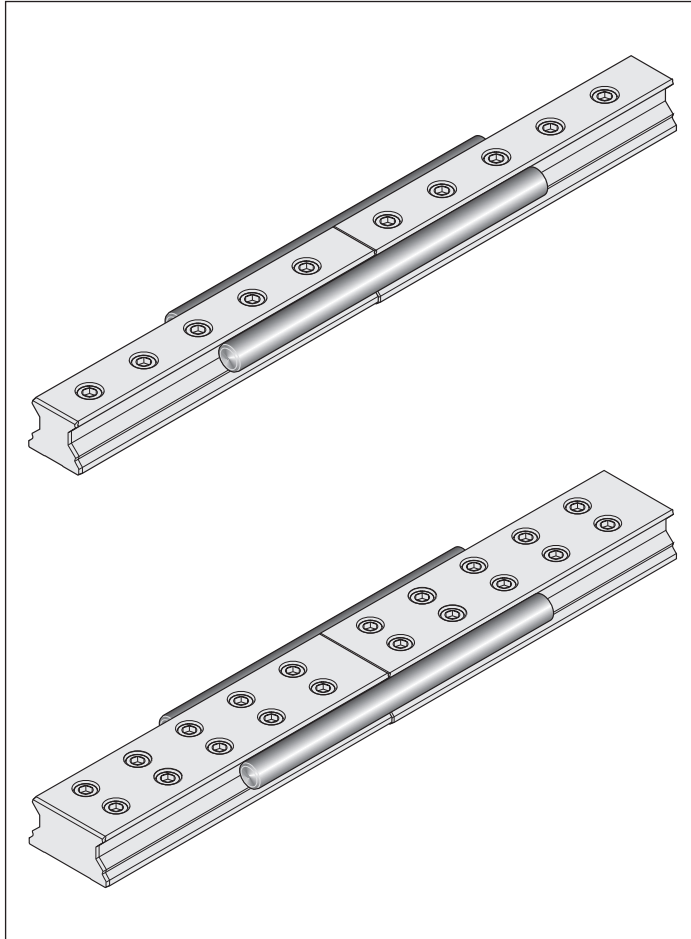

Adjusting shafts

Mounting aid for composite roller guide rails

Notes

Adjusting shafts are especially helpful when there is no reference edge.

Observe the “Mounting Instructions for Roller Rail Systems.”

Note for ordering

Always order **two** adjusting shafts for mounting.

Size	Part numbers Adjusting shaft (single)	Dimensions (mm)		Mass (kg)
		Shaft dia.	Length	
35	R1810 390 01	20	160	0.4
45	R1810 490 01	25	200	0.8
55	R1810 590 01	30	250	1.4
65	R1810 690 01	35	300	2.3
55/85	R1810 590 01	30	250	1.4
65/100	R1810 690 01	35	300	2.3
100	R1810 291 01	75	400	13.9
125	R1810 391 01	80	600	23.7

Wedge Profile

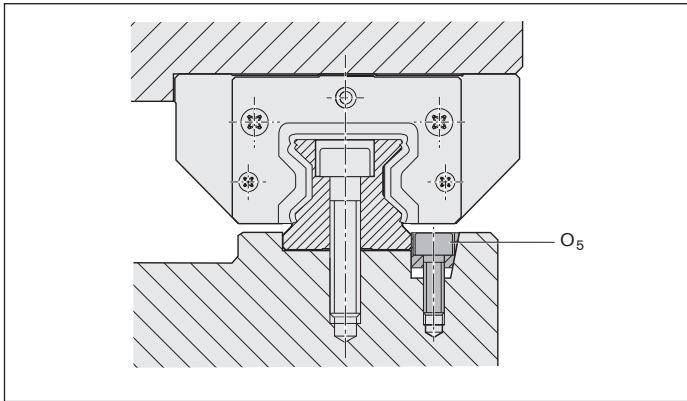

Wedge profile

Mounting aid for lateral retention of roller guide rails

- ▶ Material: steel
- ▶ Version: black finished

Observe the “Mounting Instructions for Roller Rail Systems.”

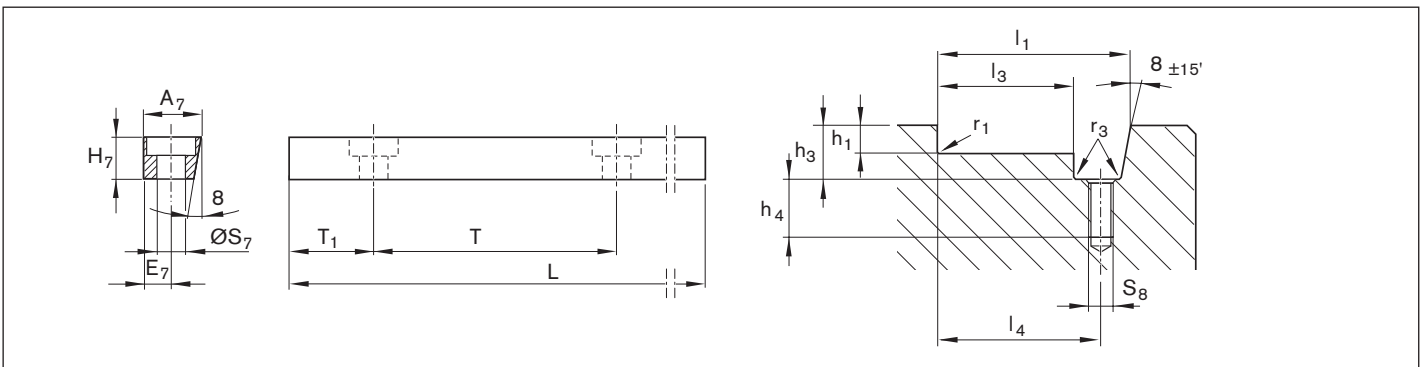

Wedge profile

Size	Part numbers	Dimensions (mm)								Mass (kg)
		A ₇	E ₇	H ₇	L	O ₅ ¹⁾	s ₇	T	T ₁	
25/30/35	R1619 200 01	12.0	6	10	957	M5x20	6.0	60	28.5	0.8
45/55/65	R1619 400 01	19.0	9	16	942	M8x25	9.0	105	51.0	2.0
100²⁾	R1810 291 02	34.0	16	23	938	M12x35	13.5	105	49	5.3
125	R1810 391 02	47.5	23	30	954	M16x45	17.5	120	57.0	9.5

1) Screw O₅ as per DIN 6912

2) Size 100 on request

Wedge profile groove

Size	Dimensions (mm)								
	h ₁ ^{-0.2}	h ₃ ⁺¹	h ₄ ⁺²	l ₁ ^{±0.05}	l ₃ ^{-0.1}	l ₄ ^{±0.1}	r ₁ max	r ₃ max	S ₈
25	4.5	12.5	15	35.1	22.9	29	0.8	0.5	M5
30^{*)}									
35	5.0	12.5	15	46.1	33.9	40	0.8	0.5	M5
45	7.0	19.0	16	64.1	44.9	54	0.8	0.5	M8
55	9.0	19.0	16	72.1	52.9	62	1.2	0.5	M8
65	9.0	19.0	16	82.1	62.9	72	1.2	0.5	M8
100	12.0	26.0	20	134.0	99.9	116	1.8	1.0	M12
125	20.0	34.0	29	172.6	124.9	148	1.8	1.0	M16

*) In preparation

End Seal

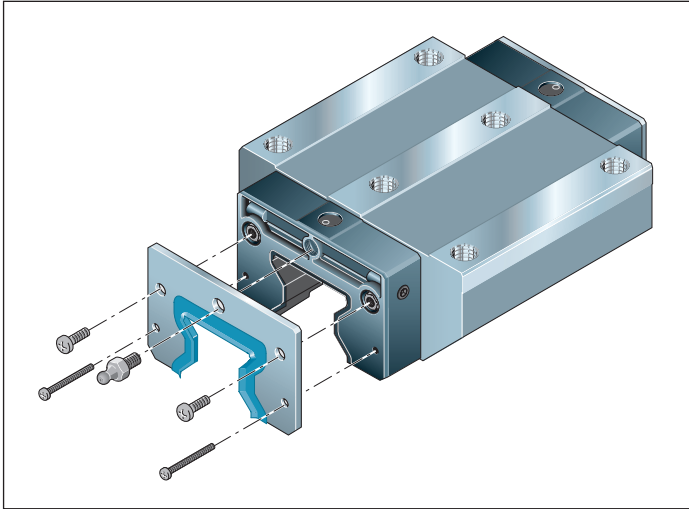

End seal

On RSHP already integrated (replacement only for generation 1 roller runner blocks)

- ▶ Material: corrosion-resistant spring steel to EN 10088 with polymer seal
- ▶ Version: bright

Notes for mounting

Comes complete with mounting screws.

- ▶ Dispose of the old screws.

For detailed information on mounting, see “Mounting Instructions for Roller Rail Systems.”

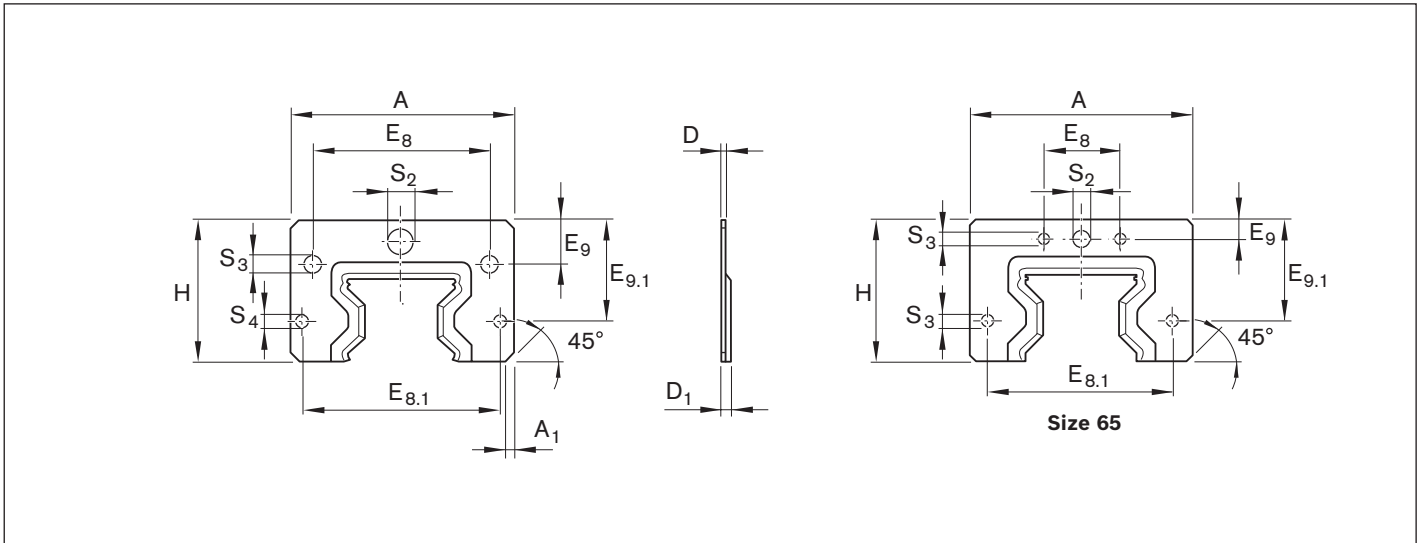

Size	Part numbers Set	Dimensions (mm)												Mass (g)
		A	A ₁	D	D ₁	E ₈	E _{8.1}	E ₉	E _{9.1}	H	S ₂	S ₃	S ₄	
55/85	R1810 512 00	122.5	2	2.0	5.3	40	113.6	10.0	50	66.2	7	6.0	4.0	82
65/100	R1810 612 00	156.0	4	2.0	5.0	72	143.0	8.3	54	74.5	7	5.0	5.0	120
65 (FXS)	R1810 610 00	119.0	3	2.0	5.0	35	106.0	8.3	54	74.5	7	5.0	5.0	108
100	R1810 211 00	181.0	2	2.5	5.5	130	162.6	28.4	61	104.0	9	6.0	6.0	280
125	R1810 311 00	230.0	5	3.0	6.0	205	205.0	38.0	90	133.0	9	6.5	6.5	530

Set of End Caps with End Seals

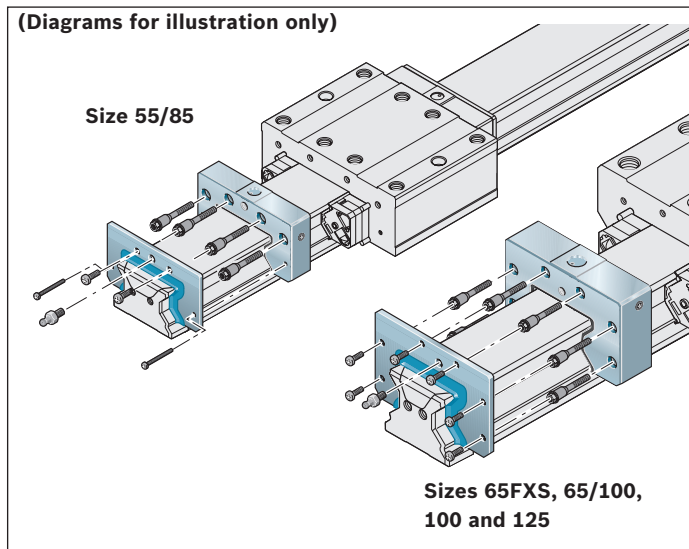

Set for wide roller runner blocks and heavy duty roller runner blocks

For replacement as part of roller runner block servicing

Notes

Comes complete with mounting screws.

- ▶ Dispose of the old screws.

For more details, see “Mounting Instructions for Roller Rail Systems.”

Size	Part numbers for set of end caps with end seals to match		Mass of set with end caps made from	
	Wide roller runner blocks	Heavy duty roller runner blocks	Plastic (kg)	Aluminum (kg)
55/85	R1810 592 60	–	–	0.30
65/100	R1810 692 60	–	–	0.65
65 (FXS)	–	R1810 690 10	0.26	–
100	–	R1810 291 10	0.61	–
125	–	R1810 391 60	–	2.30

Transport and Mounting Arbor

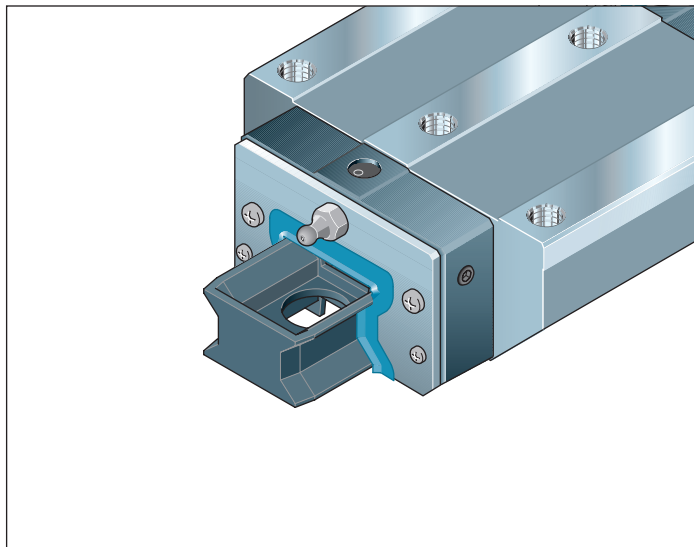

Transport and mounting arbor for roller runner blocks

For shipping and as a mounting aid

- Material: plastic

Notes

The roller runner block simply slides off its arbor and onto the rail.

Please refer to the “Mounting Instructions” section.

- ⚠ The roller runner block must remain on the arbor until it is slid onto the roller guide rail! Otherwise, rollers may be lost!

Size	Normal	Mass (g)	Long	Mass (g)
	Part numbers		Part numbers	
25	R1651 202 89	3.8	R1653 202 89	4.2
30	R1651 702 89	7.5	R1653 702 89	9.1
35	R1651 302 89	8.7	R1653 302 89	10.2
45	R1651 402 89	17.2	R1653 402 89	20.5
55	R1653 502 89	32.8	R1653 502 89	32.8
65	R1853 600 91	40.7	R1853 600 91	40.7
65 (FXS)	–	–	R1854 600 91	68.0
55/85	–	–	R1871 500 81	367.0
65/100	–	–	R1871 600 81	663.0
100	R1861 200 91	154.0	R1863 200 91	197.0
125	R1861 300 81	1888.0	R1863 300 81	2600.0

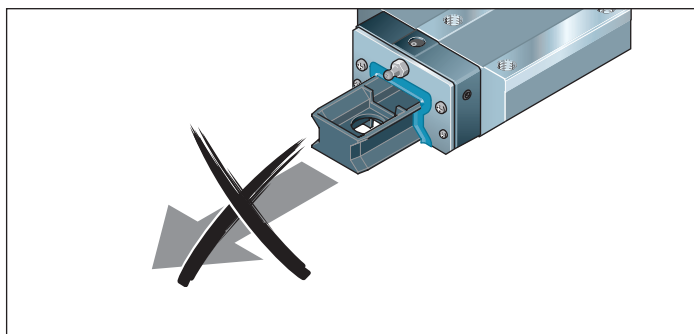

Hydraulic Clamping and Braking Units

Product Description

Application areas

Clamping

- ▶ During installation work and while machine is stopped, with power when using KBH
- ▶ Braking of heavy handling systems
- ▶ Clamping of machine tables in heavy duty machining centers

Braking

- ▶ Auxiliary brake for linear motors
- ▶ Braking of heavy handling systems

Characteristic features

- ▶ Very high axial holding forces
- ▶ Dynamic and static stabilization in the axis travel direction
- ▶ Heavy duty brake
- ▶ **⚠** Follow the safety notes for clamping and braking units.

Further highlights

- ▶ Up to 1 million clamping cycles
- ▶ Up to 2,000 emergency braking operations
- ▶ Threaded ports on both sides for connection of hydraulic circuit
- ▶ Solid, rigid steel housing, catalytically nickel-plated
- ▶ High positioning accuracy
- ▶ Release pressure 150 bar
- ▶ Integrated all-round sealing
- ▶ Special pressure diaphragm for high functional reliability without pressure losses or leakage
- ▶ Brake shoes with integral contour-locking, large-surface contact profiles for maximum axial stiffness
- ▶ Super heavy duty model

Special features of KBH:

- ▶ Low oil displacement volume
- ▶ Compact design, compatible with DIN 645
- ▶ 10 million clamping cycles (B10d value)

Function principle

Hydraulic pressure: 50 - 150 bar

Clamping and braking by pressure application

The large-surface clamping profiles are pressed directly against the free surfaces of the roller guide rail by the piston-type action of a hydraulic oil circuit.

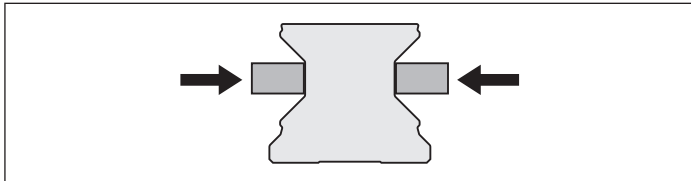

KBH, FLS

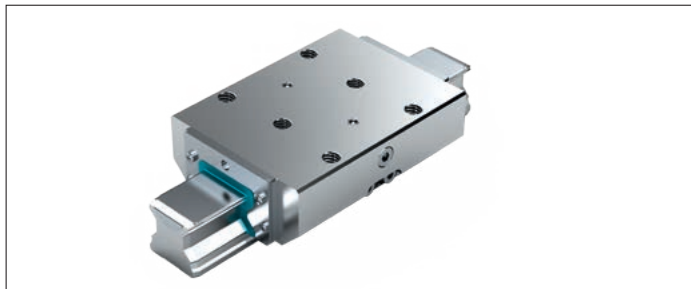

Hydraulic pressure: 0 bar

Release by spring action

A preloaded return spring provides quick release.

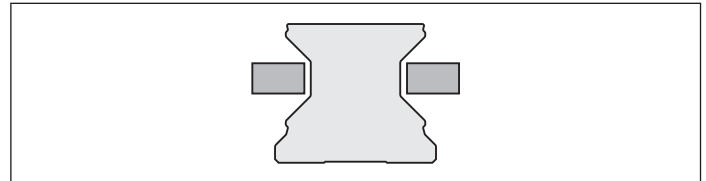

KBH, SLS

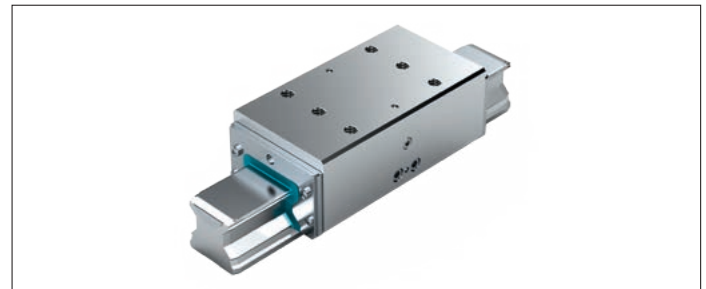

Additional information

Hydraulic ports

The hydraulic clamping units are pre-filled with HLP 46 in the factory. There is a hydraulic port on both sides. One port is sufficient for the application of pressure. During venting pay particular attention to the fixed and flexible hydraulic lines, as air bubbles can cause damage to the sealing elements.

Adjoining structure, mounting the clamping units

To avoid adverse effects, e.g. continuous rubbing against the linear guide, the adjoining structure must be designed so it is stiff in relation to its load and requirements. If the clamping units are not fitted straight, contact may occur along with wear and therefore damage to the linear guide.

The factory pre-adjustment is tailored to the linear guide and is not allowed to be changed during mounting. For this purpose it is imperative the mounting instructions for the clamping and braking units, and the linear guides are followed.

Some spring-loaded elements are fitted with a transport and mounting arbor between the contact profiles.

This item is to be removed during mounting by applying pressure to the unit. On the removal of the pressure, the transport and mounting arbor or the related linear guide must be fitted between the contact profiles!

The clamping units do not provide any guiding function. It is therefore not possible to replace a runner block with a clamping unit. The ideal position for the clamping unit is between two runner blocks.

On the usage of several clamping units, they should be distributed evenly on both guide rails to achieve maximum rigidity of the overall structure.

Lubrication

Lubrication is not necessary on the usage of the stipulated medium.

Surface protection

All clamping unit housings are chemically nickel-plated and are therefore a certain degree of protection against rust.

Aluminum sections are chemically nickel-plated or hard coated depending on their requirements.

B10d value

The B10d value defines the number of cycles until 10% of the components have failed dangerously.

Hydraulic Clamping and Braking Units KBH FLS

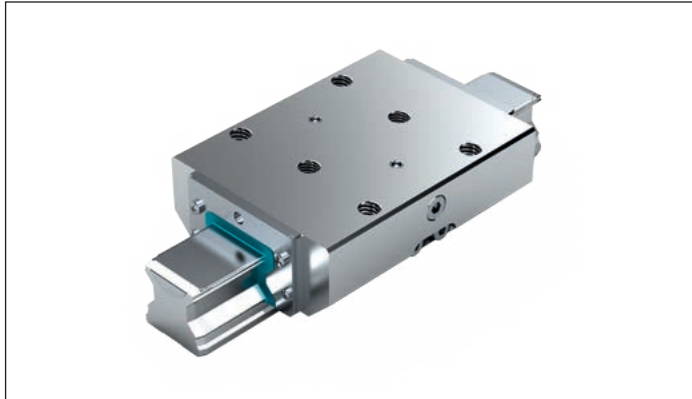

Note

Suitable for roller guide rails SNS.

Clamping and braking by pressure application

- ▶ Max. hydraulic operating pressure:
- ▶ Sizes 45 - 65: 150 bar
- ▶ Operating temperature range t: 0 - 70 °C

Lubrication notes

- ▶ First filling with hydraulic oil HLP 46
- ▶ If other oils are used, check the compatibility

⚠ Follow the safety notes for clamping and braking units.

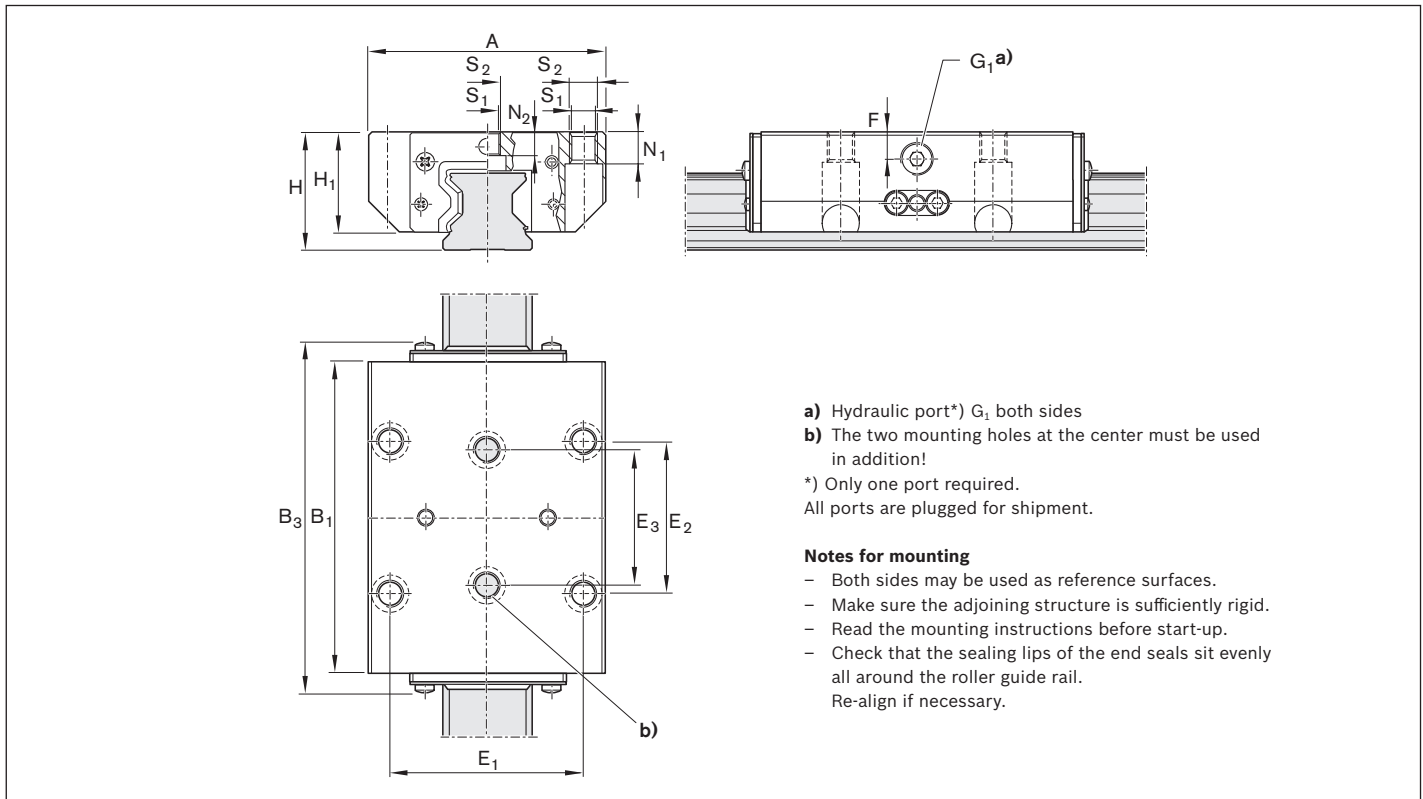

Part numbers and dimensions

Size	Part numbers	Holding force ¹⁾ (N)	Dimensions (mm)														Displacement volume ⁵⁾ (cm ³)	Mass (kg)
			A	B ₁	B ₃	H	H ₁	E ₁	E ₂	E ₃	F	G ₁	N ₁ ³⁾	N ₂ ⁴⁾	S ₁	S ₂		
45	R1810 440 21	7400 ²⁾	120	155.0	174.0	60	51.0	100	80	60	15	1/8"	15	13.5	10.5	M12	1.8	5.2
55	R1810 540 21	10200 ²⁾	140	184.0	205.0	70	58.0	116	95	70	16	1/8"	18	13.7	12.5	M14	2.4	8.4
65	R1810 640 21	22700 ²⁾	170	227.0	246.0	90	76.0	142	110	82	20	1/4"	23	21.5	14.5	M16	3.8	17.3

1) Testing is performed in the installed condition with a film of lubricating oil (ISO-VG 68).

2) At 150 bar

3) For mounting from below with ISO 4762

4) For mounting from below with DIN 7984

5) Per clamping cycle

Hydraulic Clamping and Braking Units KBH SLH

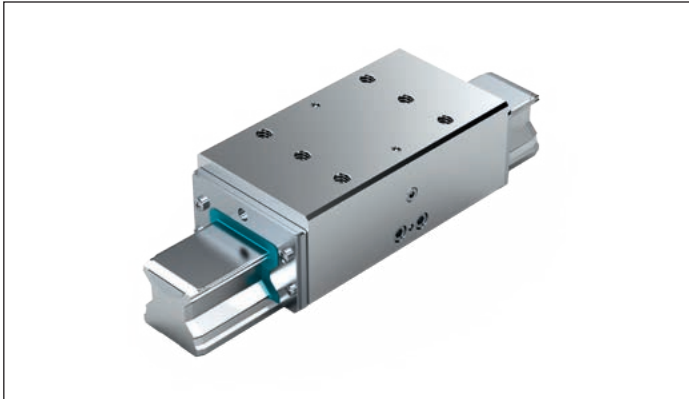

Note

Suitable for roller guide rails SNS.

Clamping and braking by pressure application

- ▶ Max. hydraulic operating pressure:
- ▶ Size 45: 150 bar
- ▶ Operating temperature range t: 0 - 70 °C

Lubrication notes

- ▶ First filling with hydraulic oil HLP 46
- ▶ If other oils are used, check the compatibility

⚠ Follow the safety notes for clamping and braking units.

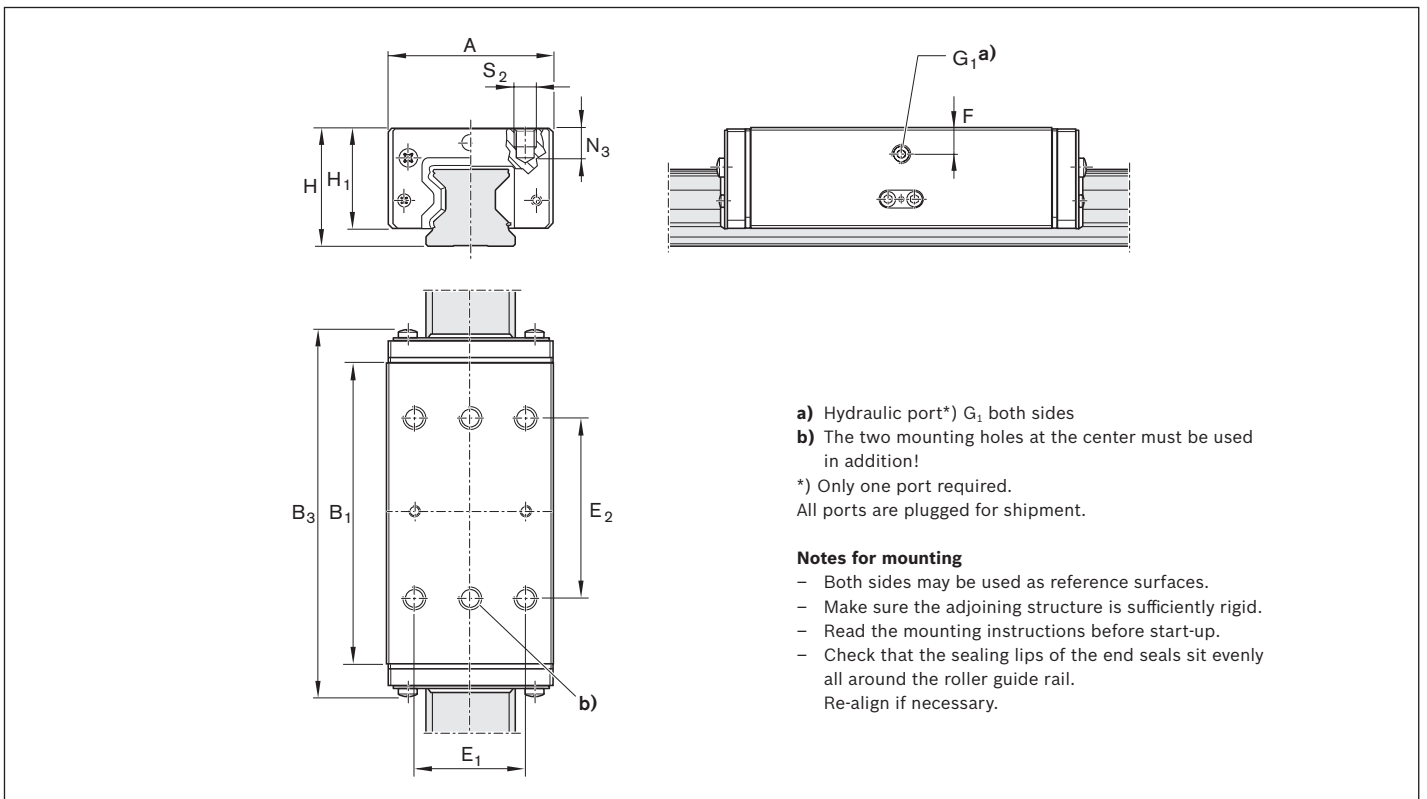

a) Hydraulic port*) G₁ both sides

b) The two mounting holes at the center must be used in addition!

*) Only one port required.

All ports are plugged for shipment.

Notes for mounting

- Both sides may be used as reference surfaces.
 - Make sure the adjoining structure is sufficiently rigid.
 - Read the mounting instructions before start-up.
 - Check that the sealing lips of the end seals sit evenly all around the roller guide rail.
- Re-align if necessary.

Part numbers and dimensions

Size	Part numbers	Holding force ¹⁾ (N)	Dimensions (mm)											Displacement volume ³⁾ (cm ³)	Mass (kg)
			A	B ₁	B ₃	H	H ₁	E ₁	E ₂	F	G ₁	N ₂	S ₂		
45	R1810 440 22	7400 ²⁾	86	155	166	70	61	60	80	24	1/8"	18	M10	1.8	5.2

1) Testing is performed in the installed condition with a film of lubricating oil (ISO-VG 68).

2) At 150 bar

3) Per clamping cycle

Safety Notes on Clamping and Braking Units

General safety notes

- ⚠ When working with clamping units, always follow all applicable mechanical and electrical accident prevention regulations (e.g. UVV, VDE) and safety procedures!
- ⚠ The clamping units do not provide any guiding function. It is therefore not possible to replace a runner block with a clamping unit. The ideal position for the clamping unit is between two runner blocks. On the usage of several clamping units, they should be distributed evenly on both guide rails to achieve maximum rigidity of the overall structure.
- ⚠ For hydraulic clamping and braking units, the return pressure in the tank line must be lower than 1.5 bar!
- ⚠ Consider the response times of the clamping and braking units!
- ⚠ The clamping unit is not intended for securing suspended loads!
- ⚠ Do not remove the cover of the safety clamping unit – spring under tension!
- ⚠ The transport safety arbor may only be removed when:
 - the hydraulic port has been pressurized with the operating pressure according to instructions.
 - The air port has been pressurized with compressed air to at least 4.5 (MBPS) or 5.5 bar (UBPS, MKS) according to instructions.
- ⚠ The clamping unit may only be depressurized when the appropriate roller guide rail or transport safety arbor is in position between the contact profiles!
- ⚠ The use of clamping and braking units is not permitted on roller guide rails with integrated measuring systems!

Additional notes for clamping and braking units

- ⚠ The clamping and braking units are suitable for usage in safety-critical applications for braking and clamping. The safe function of the entire system in which the clamping and braking units are used is primarily defined by the controller for this system. The technical design of this system and the controller is to be undertaken by the manufacturer of the higher level system, assembly, plant or machine. During this process the safety-related requirements for functional safety are to be observed.

Additional notes for clamping units

- ⚠ The unit may not be used as a braking unit! For use only when the axis is at a standstill!
- ⚠ Pressure may only be applied when the unit is properly mounted on the roller guide rail!

Hydraulic Clamping Units Product Description

Application areas

- ▶ Clamping of heavy handling systems
- ▶ Clamping of machine tables in heavy duty machining centers

Characteristic features

- ▶ Very high axial holding forces
- ▶ Compact design, compatible with DIN 645
- ▶ Dynamic and static stabilization in the axis travel direction

⚠ Follow the safety notes for clamping and braking units.

Further highlights

- ▶ Threaded ports on both sides for connection of hydraulic circuit
- ▶ Solid, rigid steel housing, catalytically nickel-plated
- ▶ High positioning accuracy
- ▶ Steplessly adjustable pressure from 50 - 150 bar
- ▶ Integrated all-round sealing
- ▶ Special pressure diaphragm for high functional reliability without pressure losses or leakage
- ▶ Integrated contour-locking, large-surface contact profiles for maximum axial stiffness

Special features of KWH:

- ▶ 10 million clamping cycles (B10d value)

Function principle

Hydraulic pressure: 50 - 150 bar

Clamping and braking by pressure application

The large-surface clamping profiles are pressed directly against the free surfaces of the roller guide rail by the piston-type action of a hydraulic oil circuit.

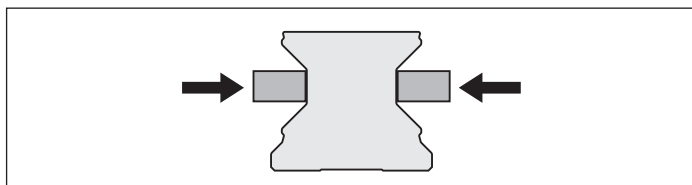

Hydraulic pressure: 0 bar

Release by spring action

A preloaded return spring provides quick release.

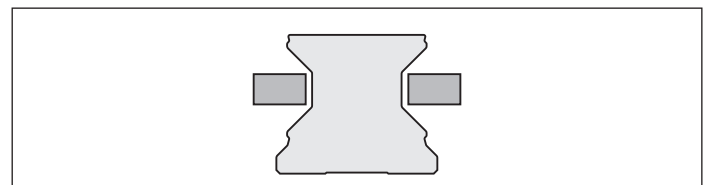

KWH, FLS

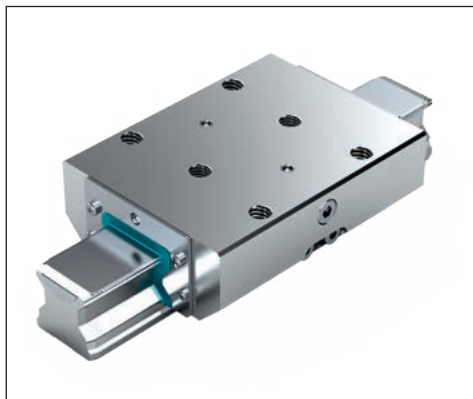

KWH, SLS

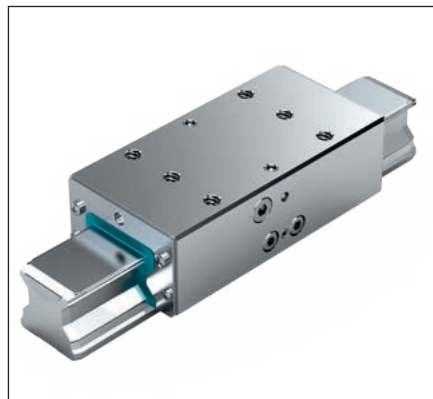

KWH, SLH

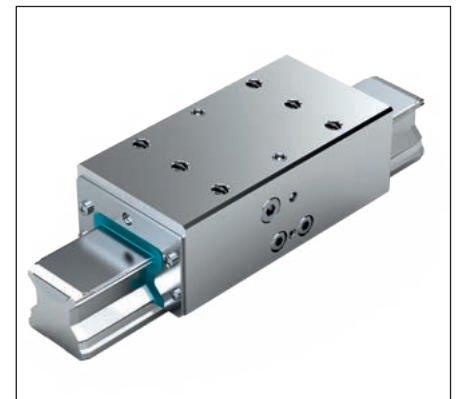

Technical Data and Calculations

Normal forces and holding forces

Measured values for hydraulic clamping unit KWH, FLS – flanged, long, standard height, sizes 25 - 65

Max. operating pressure hydraulic:

- ▶ Sizes 25 - 30: 100 bar
- ▶ Sizes 35 - 65: 150 bar

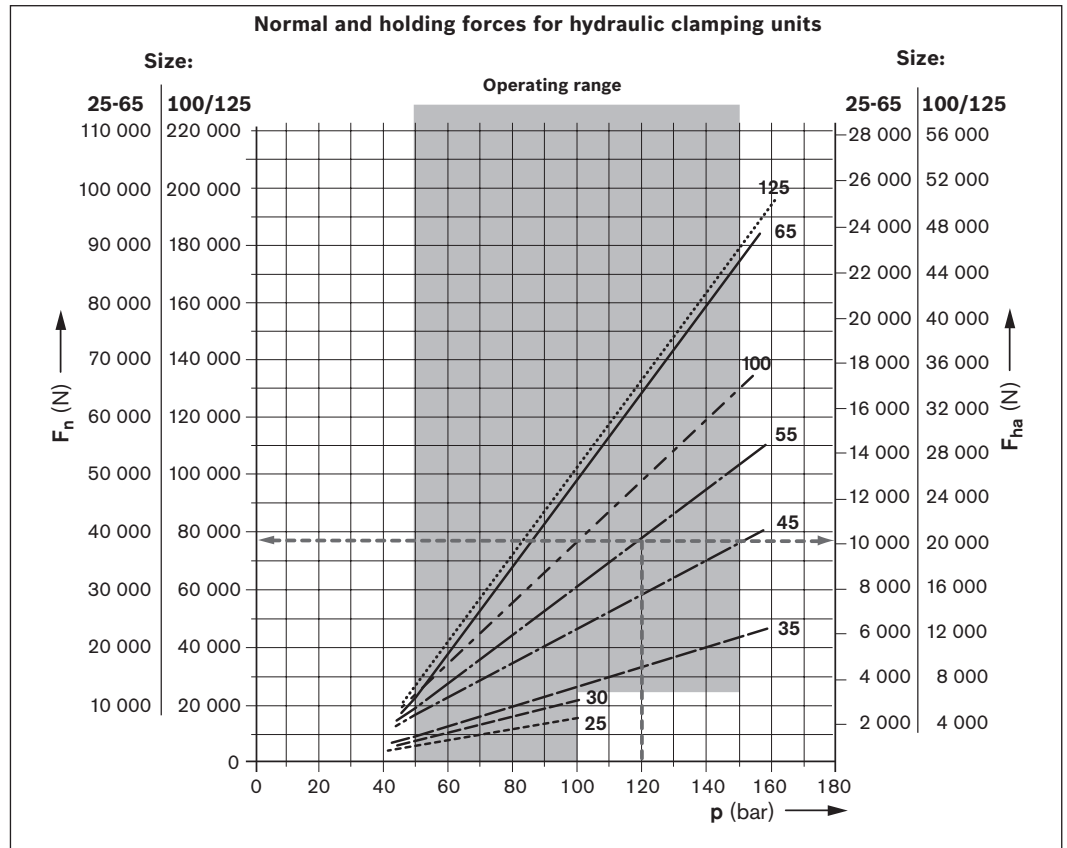

Calculation of holding force

Holding force for hydraulic clamping units

$$F_{ha} = F_n \cdot 2 \cdot \mu_0$$

Normal force (measures): F_n see diagram
 Stiction coefficient: $\mu_0 = 0.13$ (approx.) for steel/steel, oiled, referred to roller guide rail

Calculation example: Clamping unit KWH size 55

Pressure: $p = 120$ bar
 Normal force: $F_n = 38500$ N (see diagram)
 Holding force: $F_{ha} = 38500 \text{ N} \cdot 2 \cdot 0.13 = 10010$ N

Permissible holding force for hydraulic clamping units

$$F_{ha, perm} = F_{ha} / f_s$$

The safety factor f_s depends on:

- ▶ Vibrations
- ▶ Force surges
- ▶ Application-specific requirements, etc.

Example: Clamping unit KWH size 55

Holding force: $F_{ha} = 10010$ N (see calculation example)
 Safety factor: $f_s = 1.25$ (assumed)
 Permissible holding force: $F_{ha, perm} = 10010 \text{ N} / 1.25 \approx 8000$ N

- f_s = safety factor (-)
- F_{ha} = holding force (N)
- (at $\mu_0 = 0.13$)
- $F_{ha, perm}$ = permissible holding force (N)
- F_n = normal force (N)
- μ_0 = stiction coefficient (-)
- p = pressure (bar)

Hydraulic Clamping Units KWH FLS

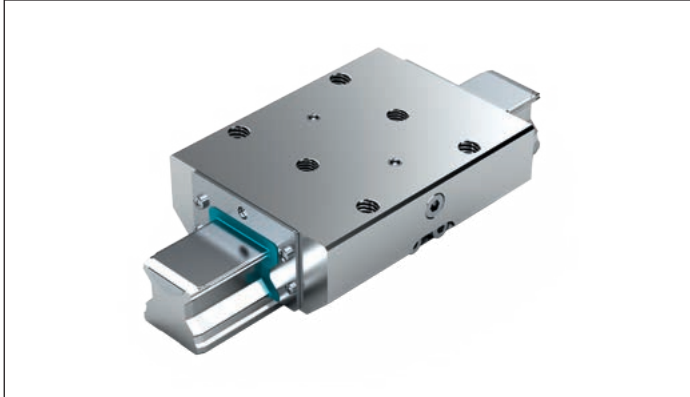

Note

Suitable for roller guide rails SNS.

Clamping and braking by pressure application

- ▶ Max. hydraulic operating pressure:
- ▶ Size 25: 100 bar
- ▶ Sizes 35 - 125: 150 bar
- ▶ Operating temperature range t: 0 - 70 °C

Lubrication notes

- ▶ First filling with hydraulic oil HLP 46
- ▶ If other oils are used, check the compatibility

⚠ Follow the safety notes for clamping and braking units.

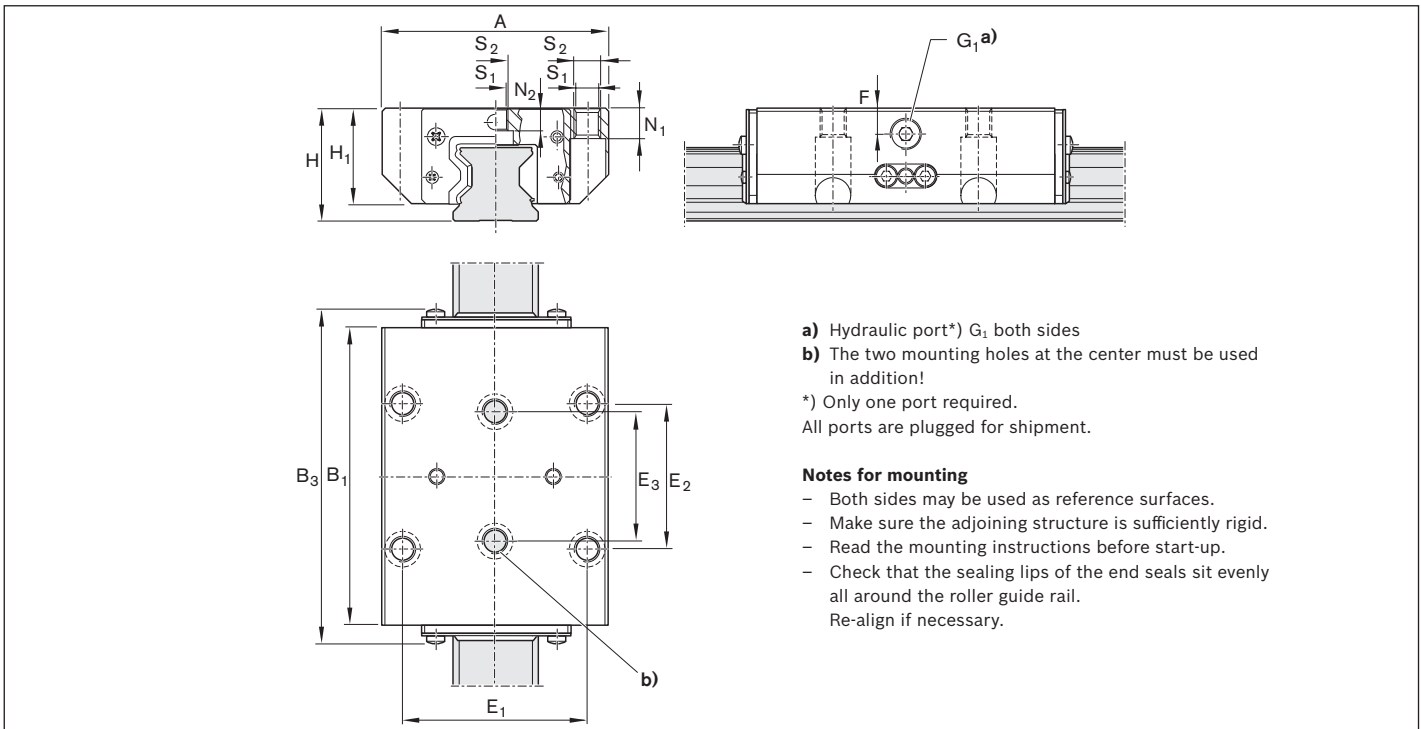

- a) Hydraulic port*) G₁ both sides
 - b) The two mounting holes at the center must be used in addition!
 - *) Only one port required.
- All ports are plugged for shipment.

Notes for mounting

- Both sides may be used as reference surfaces.
 - Make sure the adjoining structure is sufficiently rigid.
 - Read the mounting instructions before start-up.
 - Check that the sealing lips of the end seals sit evenly all around the roller guide rail.
- Re-align if necessary.

Part numbers and dimensions

Size	Part numbers	Holding force ¹⁾ (N)	Dimensions (mm)														Displacement volume ⁶⁾ (cm ³)	Mass (kg)
			A	B ₁	B ₃	H	H ₁	E ₁	E ₂	E ₃	F	G ₁	N ₁ ⁴⁾	N ₂ ⁵⁾	S ₁	S ₂		
25	R1810 242 11	2 200 ²⁾	70	92.0	99.3	36	30.0	57	45	40	9.5	1/8"	9	7.3	6.8	M8	0.6	1.22
35	R1810 342 11	5 700 ³⁾	100	120.5	128.0	48	41.0	82	62	52	12.0	1/8"	12	11.0	8.6	M10	1.1	2.69
45	R1810 442 11	9 900 ³⁾	120	155.0	166.0	60	51.0	100	80	60	15.0	1/8"	15	13.5	10.5	M12	1.8	5.32
55	R1810 542 11	13 700 ³⁾	140	184.0	197.0	70	58.0	116	95	70	16.0	1/8"	18	13.7	12.5	M14	2.4	8.40
65	R1810 642 11	22 700 ³⁾	170	227.0	238.0	90	76.0	142	110	82	20.0	1/4"	23	21.5	14.5	M16	3.8	17.30
100	R1810 243 11	34 000 ³⁾	250	200.0	222.6	120	105.0	200	150	150	20.0	1/4"	30	17.5	17.5	M20	5.0	29.1
125	R1810 343 11	46 000 ³⁾	320	227.0	246.0	160	135.0	270	102.5	102.5	50.0	1/4"	45	29.0	24.0	M27	7.6	53.7

1) Testing is performed in the installed condition with a film of lubricating oil (ISO-VG 68). For permissible holding force see technical data and calculations.

2) At 100 bar

3) At 150 bar

4) For mounting from below with ISO 4762

5) For mounting from below with DIN 7984

6) Per clamping cycle

Hydraulic Clamping Units KWH SLS

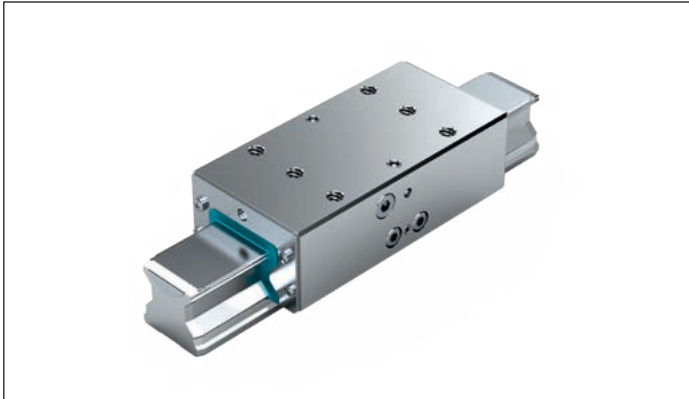

Note

Suitable for roller guide rails SNS.

Clamping and braking by pressure application

- ▶ Max. hydraulic operating pressure:
- ▶ Size 65: 150 bar
- ▶ Operating temperature range t: 0 - 70 °C

Lubrication notes

- ▶ First filling with hydraulic oil HLP 46
- ▶ If other oils are used, check the compatibility

⚠ Follow the safety notes for clamping and braking units.

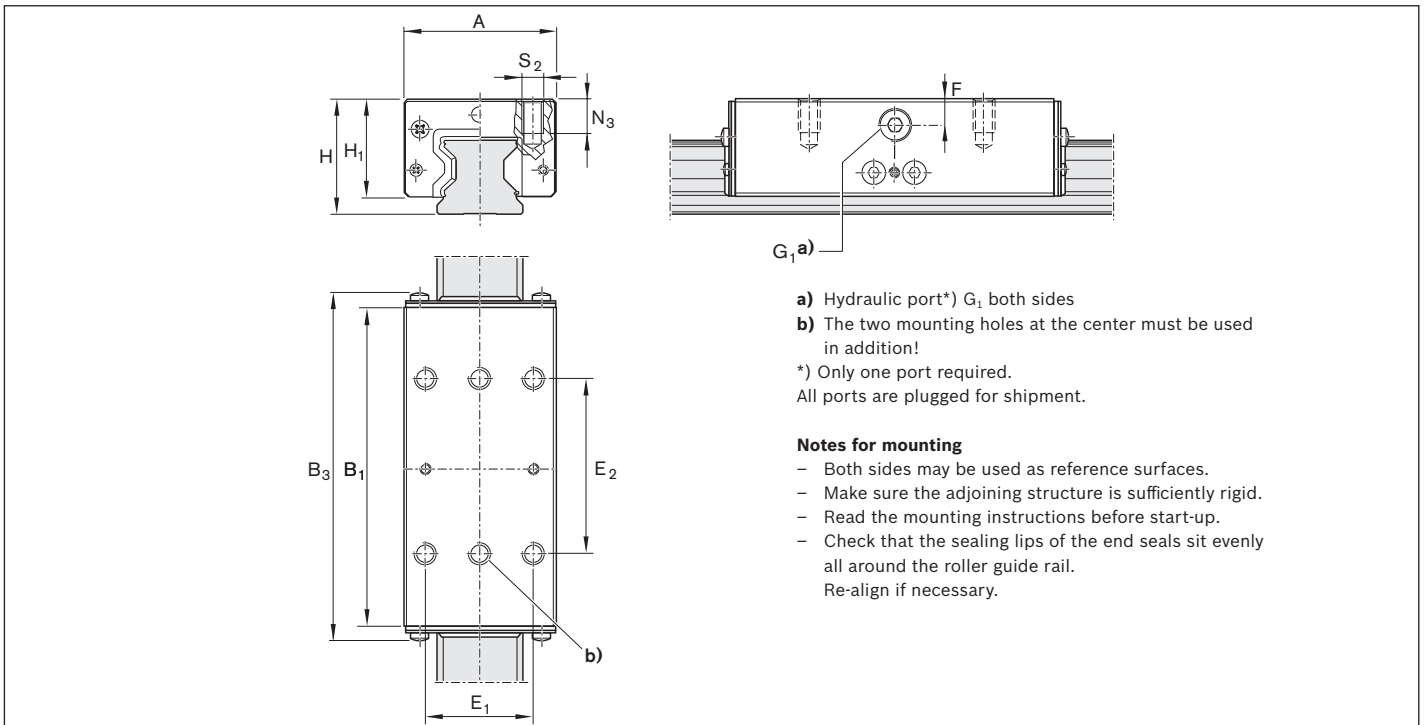

a) Hydraulic port*) G₁ both sides

b) The two mounting holes at the center must be used in addition!

*) Only one port required.
All ports are plugged for shipment.

Notes for mounting

- Both sides may be used as reference surfaces.
- Make sure the adjoining structure is sufficiently rigid.
- Read the mounting instructions before start-up.
- Check that the sealing lips of the end seals sit evenly all around the roller guide rail.
Re-align if necessary.

Part numbers and dimensions

Size	Part numbers	Holding force ¹⁾ (N)	Dimensions (mm)											Displacement volume ³⁾ (cm ³)	Mass (kg)
			A	B ₁	B ₃	H	H ₁	E ₁	E ₂	F	G ₁	N ₃	S ₂		
65	R1810 642 51	22700 ²⁾	126	227.0	238.0	90	76.0	76	120	20	1/4"	21	M16	3.8	15.4

1) Testing is performed in the installed condition with a film of lubricating oil (ISO-VG 68). For permissible holding force see technical data and calculations.

2) At 150 bar

3) Per clamping cycle

Hydraulic Clamping Units KWH SLH

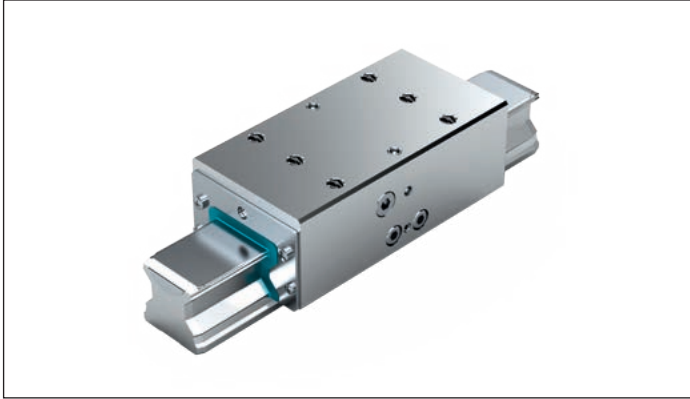

Note

Suitable for roller guide rails SNS.

Clamping and braking by pressure application

- ▶ Max. hydraulic operating pressure:
- ▶ Sizes 25 - 35: 100 bar
- ▶ Sizes 45 - 55: 150 bar
- ▶ Operating temperature range t: 0 - 70 °C

Lubrication notes

- ▶ First filling with hydraulic oil HLP 46
- ▶ If other oils are used, check the compatibility

⚠ Follow the safety notes for clamping and braking units.

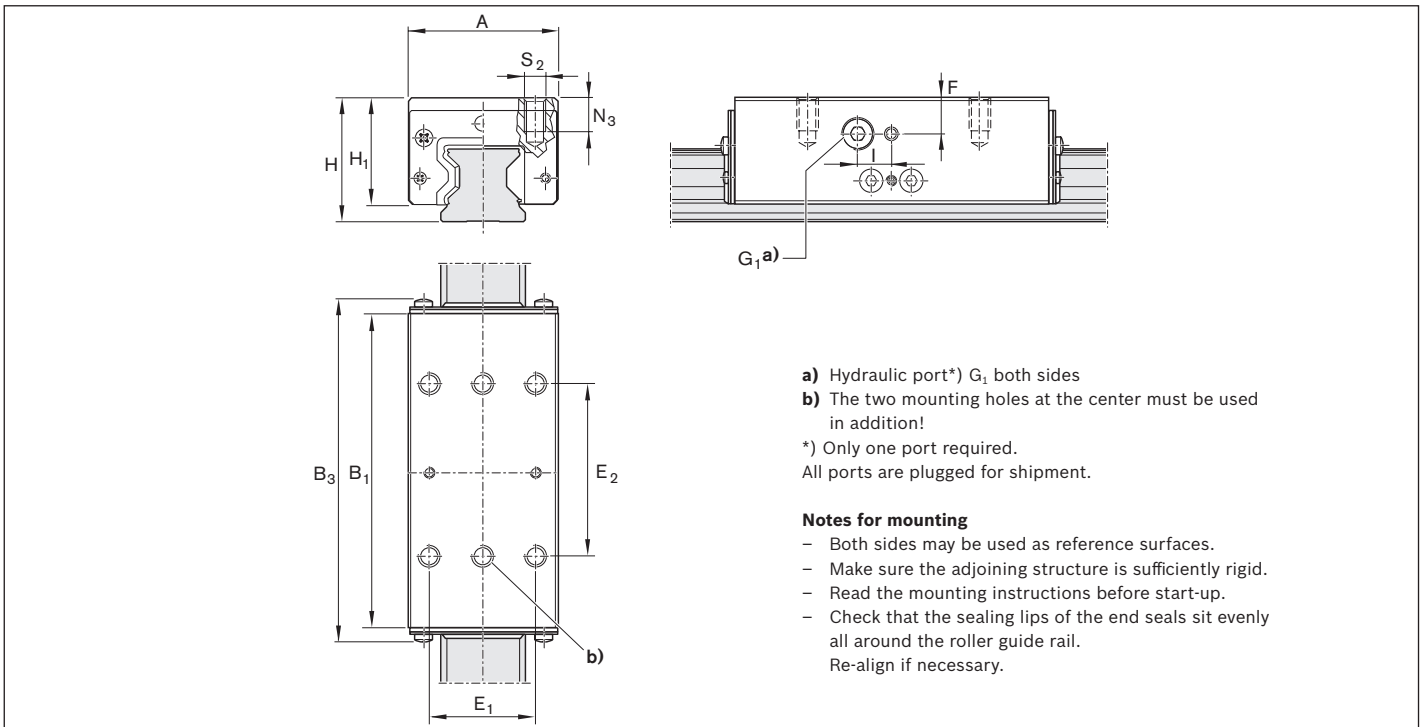

Part numbers and dimensions

Size	Part numbers	Holding force ¹⁾ (N)	Dimensions (mm)												Displacement volume ⁴⁾ (cm ³)	Mass (kg)
			A	B ₁	B ₃	H	H ₁	E ₁	E ₂	F	G ₁	i	N ₃	S ₂		
25	R1810 242 31	1 600 ²⁾	48	92.0	99.3	40	33.5	35	50	12	1/8"	10	12	M6	0.6	1.10
35	R1810 342 31	3 500 ²⁾	70	120.5	129.9	55	48.0	50	72	18	1/8"	-	13	M8	1.1	2.46
45	R1810 442 31	9 900 ³⁾	86	155.0	166.0	70	61.0	60	80	24	1/8"	-	18	M10	1.8	4.95
55	R1810 542 31	13 700 ³⁾	100	184.0	197.0	80	68.0	75	95	26	1/8"	-	19	M12	2.4	7.90

1) Testing is performed in the installed condition with a film of lubricating oil (ISO-VG 68). For permissible holding force see technical data and calculations.

2) At 100 bar

3) At 150 bar

4) Per clamping cycle

Pneumatic Clamping and Braking Units Product Description

Application areas

Clamping

- ▶ In the event of a pressure drop
- ▶ During installation work and while machine is stopped, without power
- ▶ Clamping of axes in machining centers
- ▶ Clamping of Z-axes in rest positions

Braking

- ▶ In the event of a power failure
- ▶ In the event of a pressure drop
- ▶ Reinforcing the E-Stop function
- ▶ Auxiliary brake for linear motors

Characteristic features

- ▶ Clamping and braking by spring energy accumulator
- ▶ Integrated contour-locking contact profiles for maximum axial and horizontal stiffness, providing excellent braking action
- ▶ Dynamic and static stabilization in the axis travel direction

Special feature of MBPS/UBPS:

- ▶ 5 million clamping cycles (B10d value)

⚠ Follow the safety notes for clamping and braking units.

Function principle

Air pressure: 0 bar

Clamping and braking by spring action

In the event of a pressure drop, braking or clamping is achieved by a dual-action tapered slide valve mechanism with two spring assemblies (spring energy accumulators). An integrated quick venting valve ensures fast response.

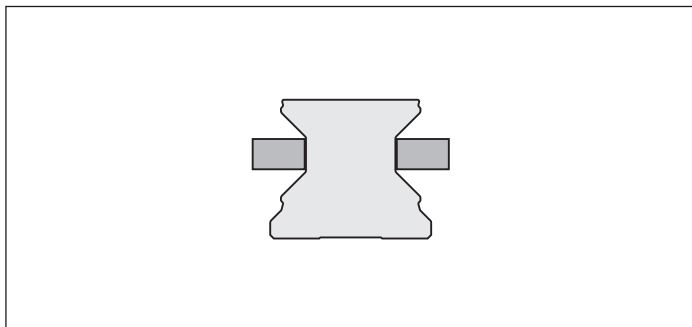

Air pressure: 4.5 - 8 bar (MBPS)

5.5 - 8 bar (UBPS)

Release by air pressure

The clamping profiles are held apart by compressed air.

- ▶ Allows free movement

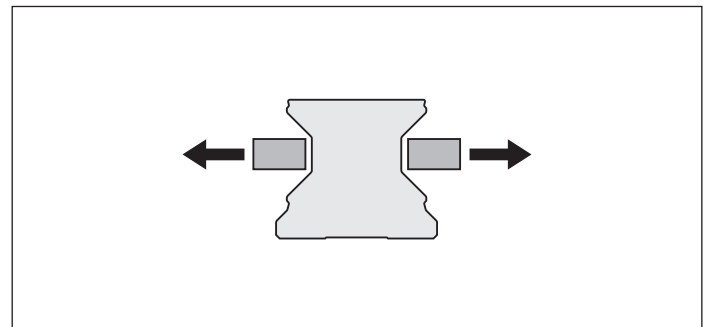

Further highlights

- ▶ Up to 1 million clamping cycles
- ▶ Up to 2,000 emergency braking operations
- ▶ Integrated all-round sealing
- ▶ High continuous performance
- ▶ High positioning accuracy
- ▶ Tapered valve mechanism
- ▶ Solid, rigid steel housing, catalytically nickel-plated
- ▶ Low air consumption
- ▶ Zero maintenance

Special features of MBPS:

- ▶ Clamping and braking unit in compact, short design
- ▶ Add-ons with three pistons connected in series combined with strong springs result in holding forces up to 3,800 N at just 4.5 bar release pressure
- ▶ 5 million clamping cycles (B10d value)¹⁾

Special features of UBPS:

- ▶ Very high axial holding forces up to 7,700 N at 5.5 bar release pressure due to strong spring energy accumulators
- ▶ Holding force can be increased to 9,200 N through additional pressurization with compressed air at the air-plus port
- ▶ Extremely low air consumption
- ▶ Compact design, compatible with DIN 645
- ▶ 5 million clamping cycles (B10d value)¹⁾

1) B10d value is not achieved on air-plus port

MBPS

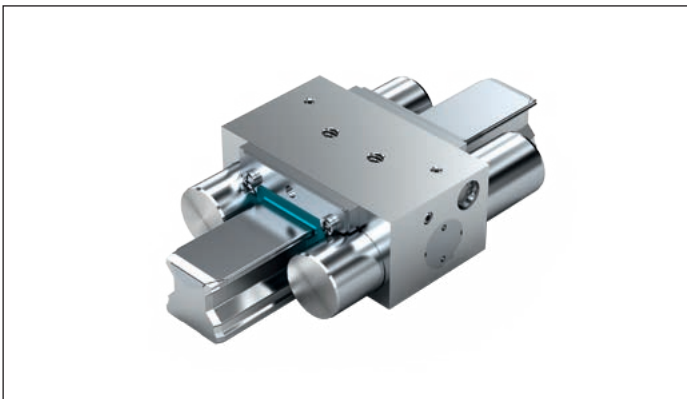

UBPS

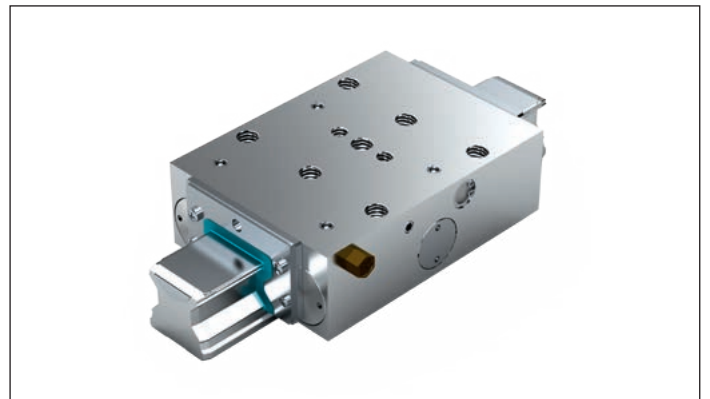

Pneumatic Clamping and Braking Units MBPS

R1810 .40 31

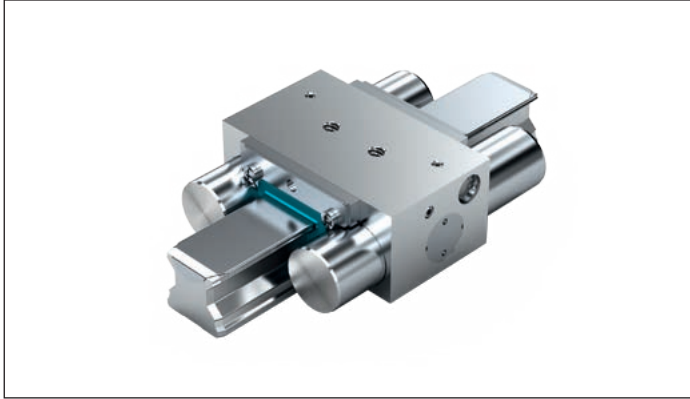

Note

- ▶ Suitable for roller guide rails SNS.

Pressureless clamping and braking (spring energy)

- ▶ Release pressure min. 4.5 bar
- ▶ Max. pneumatic operating pressure: 8 bar
- ▶ Operating temperature range t: 0 - 70 °C

Notes for mounting

- ▶ Make sure the adjoining structure is sufficiently rigid.
- ▶ Use only filtered air. The specified filter mesh size is 25 µm.
- ▶ Read the mounting instructions before start-up.
- ▶ Check that the sealing lips of the end seals sit evenly all around the roller guide rail. Re-align if necessary.

⚠ Follow the safety notes for clamping and braking units.

Circuitry for standard air port

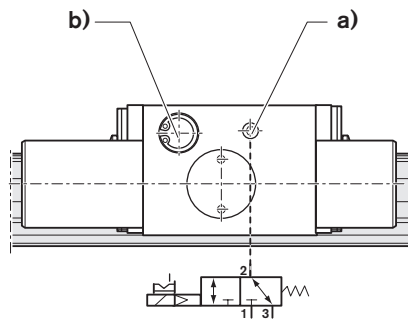

- 1 Air port
- 2 Operating ports
- 3 Venting

Technical data

Size	Part numbers	Holding force Spring energy ¹⁾ (N)	Air consumption (normalized) Air port (dm ³ /Hub)	Mass (kg)
25	R1810 240 31	1 300	0.048	1.0
30 ^{*)}				
35	R1810 340 31	2 600	0.093	1.9
45	R1810 440 31	3 800	0.099	2.3
55	R1810 540 31	4 700	0.244	3.7

^{*)} In preparation

¹⁾ Holding force achieved by spring energy. Testing is performed in the installed condition with a film of lubricating oil (ISO-VG 68).

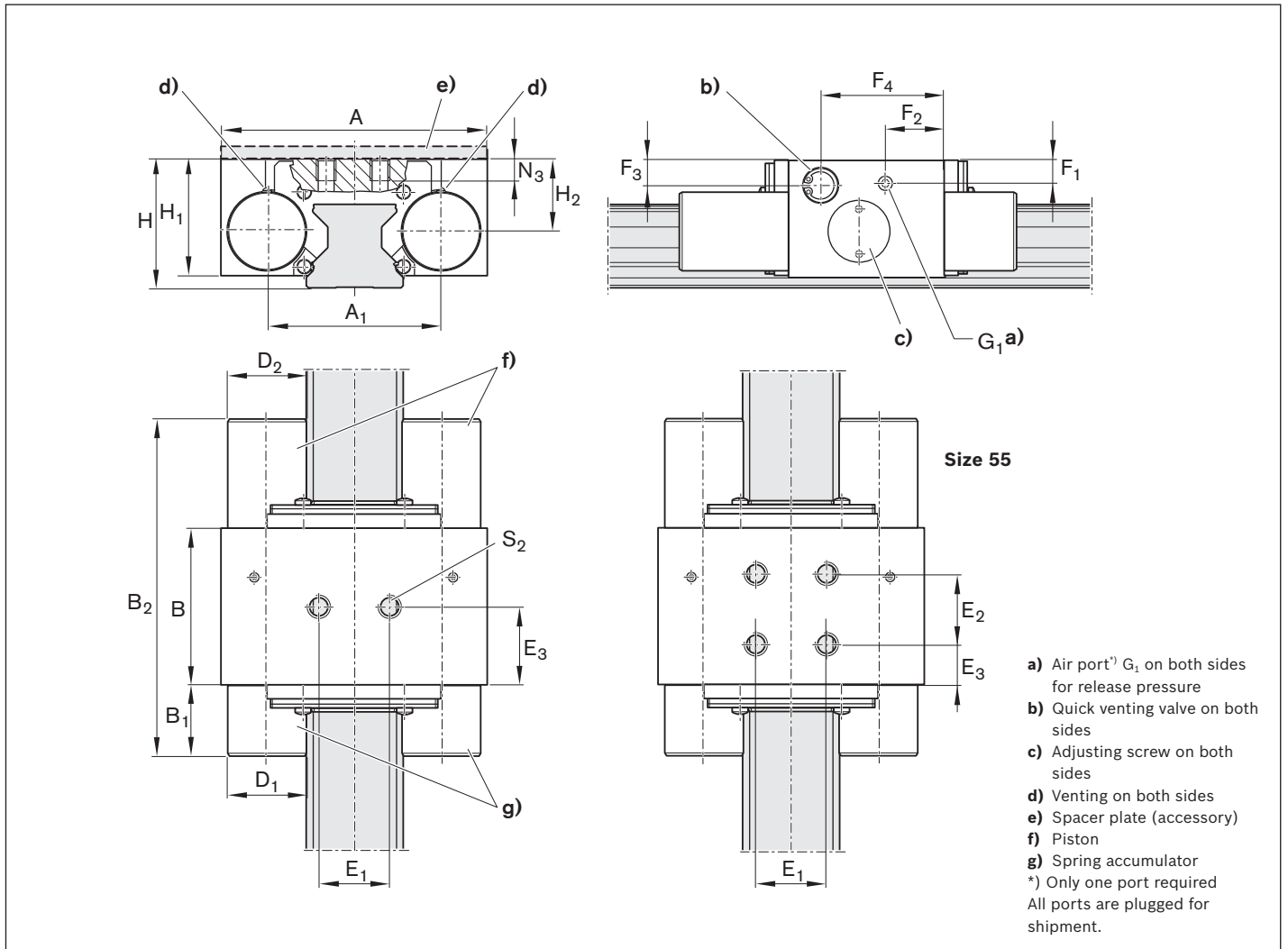
Dimensions (mm)

Size	A	A ₁	B	B ₁	B _{2 max}	D ₁	D ₂	E ₁	E ₂	E ₃
25	75	49.0	44	20.2	95.7	22	22	20	-	22.0
30^{*)}										
35	100	68.0	46	27.7	106.2	28	28	24	-	24.5
45	120	78.8	49	32.2	113.7	30	30	26	-	24.5
55	140	97.0	62	41.0	145.0	39	39	38	38	12.0

Size	F ₁	F ₂	F ₃	F ₄	G ₁	H	H _{1¹⁾}	H ₂	N ₃	S ₂
25	6.5	16.5	7.0	34.7	M5	36	32.5	20.0	8	M6
30^{*)}										
35	9.0	19.0	9.5	38.0	G1/8"	48	42.0	26.5	10	M8
45	15.0	31.1	12.2	41.6	G1/8"	60	52.0	35.5	15	M10
55	11.0	23.0	11.0	40.0	M5	70	59.0	38.0	18	M10

*) In preparation

1) For roller runner block .H. (High), a spacer plate is needed.

Pneumatic Clamping and Braking Units UBPS

R1810 .40 51

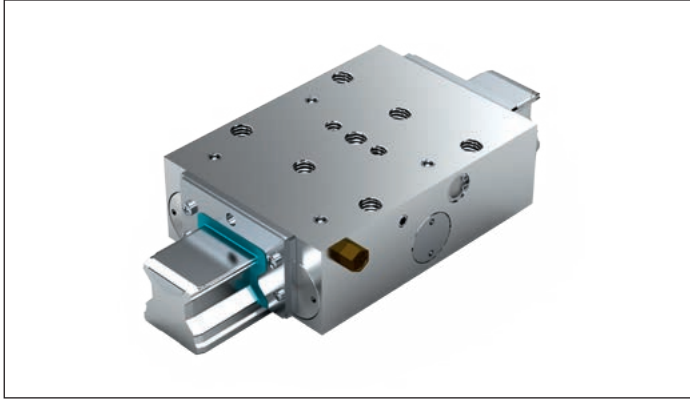

Very high axial holding forces due to three pistons connected in series combined with strong spring energy accumulator; increased holding force thanks to additional pressure through the air-plus port

Note

- ▶ Suitable for roller guide rails SNS.

Pressureless clamping and braking (spring energy)

- ▶ Release pressure min. 5.5 bar
- ▶ Max. pneumatic operating pressure: 8 bar
- ▶ Operating temperature range t: 0 - 70 °C

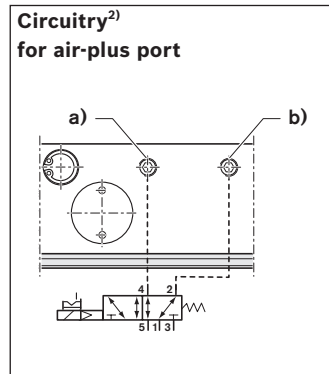
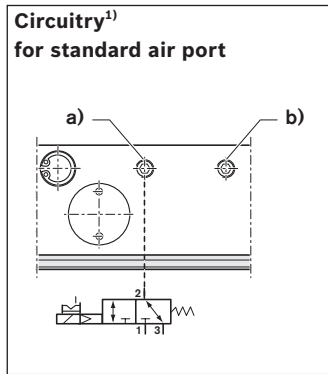

- 1 Air port
- 2 4 Operating ports
- 3 5 Venting

Notes for mounting

- ▶ Both sides may be used as reference surfaces.
- ▶ Make sure the adjoining structure is sufficiently rigid.
- ▶ Use only filtered air.
The specified filter mesh size is 25 µm.
- ▶ Read the mounting instructions before start-up.
- ▶ Check that the sealing lips of the end seals sit evenly all around the roller guide rail. Re-align if necessary.

⚠ Follow the safety notes for clamping and braking units.

Technical data

Size	Part numbers	Spring energy holding force ¹⁾		Air consumption (normalized)		Mass (kg)
		Air port (N)	with air-plus port (N)	Air port (dm ³ /Hub)	Air-plus port (dm ³ /Hub)	
25	R1810 240 51	1 850	2 650	0.080	0.165	1.20
30 ^{*)}						
35	R1810 340 51	2 800	3 800	0.139	0.303	2.25
45	R1810 440 51	5 200	7 600	0.153	0.483	6.20
55	R1810 540 51	7 700	9 200	0.554	0.952	9.40

^{*)} In preparation

- 1) Holding force achieved by spring energy. Testing is performed in the installed condition with a film of lubricating oil (ISO-VG 68).
- 2) Increased holding force through additional pressurization with 6.0 bar compressed air at the air-plus port. Switching via 5/2 or 5/3-way directional control valve.

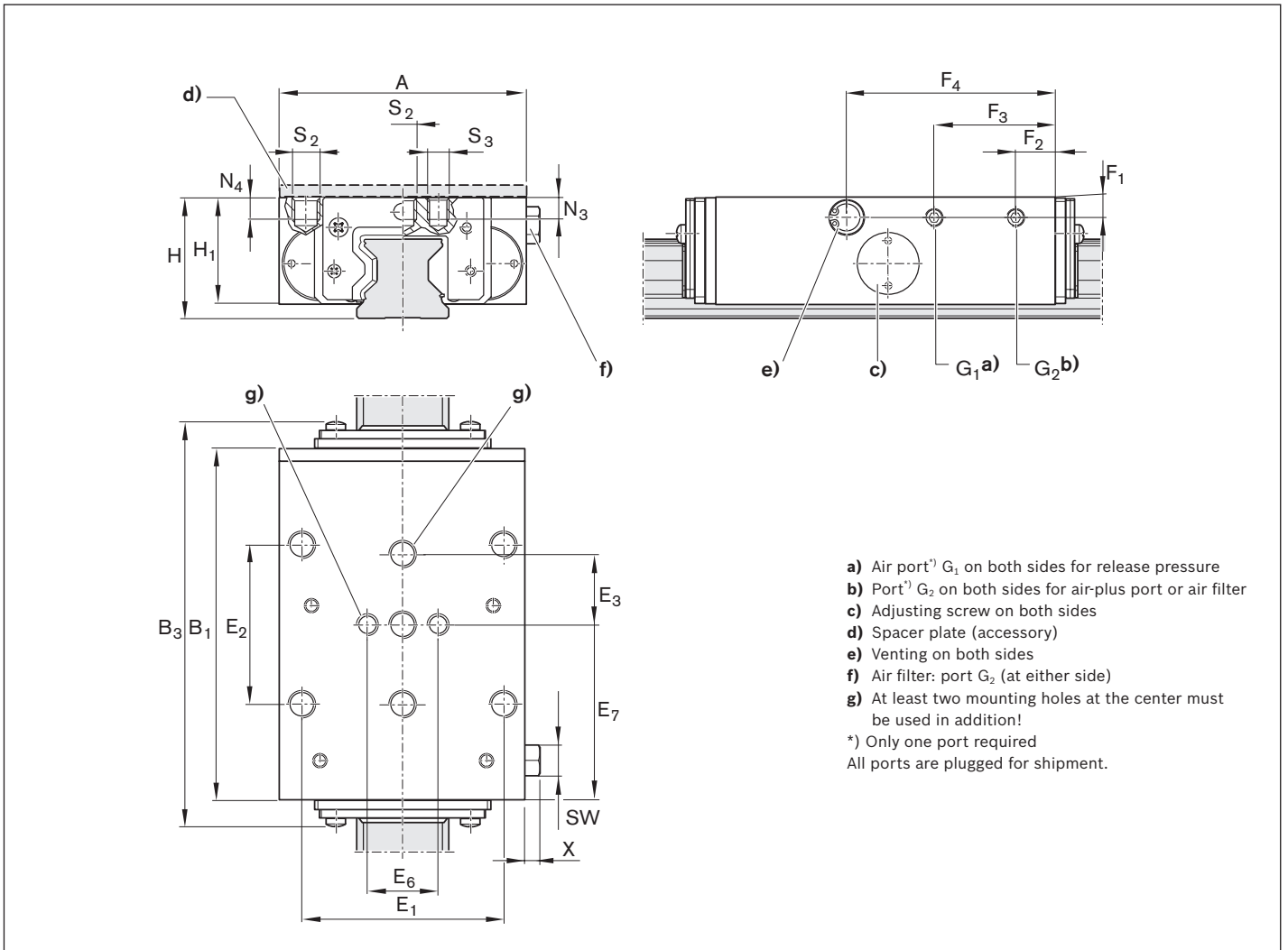
Dimensions (mm)

Size	A	B ₁	B _{3 max}	E ₁	E ₂	E ₃	E ₆	E ₇	F ₁	F ₂	F ₃	F ₄
25	70	99	112.3	57	45	20	20	49.5	6.5	11.0	34.3	59.0
30^{*)}												
35	100	109	124.8	82	62	26	24	54.5	8.0	11.0	40.8	66.5
45	120	199	218.4	100	80	30	-	99.5	12.0	32.0	167.0	106.5
55	140	197	215.8	116	95	35	-	98.5	13.0	32.0	165.0	103.5

Size	G ₁	G ₂	H	H ₁ ¹⁾	N ₃	N ₄	S ₂	S ₃	X	SW ²⁾
25	M5	M5	36	31	7	7	M8	M6	5.5	Ø8, SW7
30^{*)}										
35	G1/8"	G1/8"	48	42	10	10	M10	M8	6.5	Ø15, SW13
45	G1/8"	G1/8"	60	52	-	12	M12	-	6.5	Ø15, SW13
55	G1/8"	G1/8"	70	60	-	14	M14	-	6.5	Ø15, SW13

*) In preparation

1) For roller runner block .H. (High), a spacer plate is needed.

2) SW = WAF (width across flats)

Pneumatic Clamping Units Product Description

Application areas

Clamping

- ▶ Pneumatic clamping of machine axes
- ▶ Table crossbars in the woodworking industry
- ▶ Positioning of hoists

⚠ Follow the safety notes for clamping and braking units.

Characteristic features

- ▶ High axial holding forces within a very short span
- ▶ Dynamic and static stabilization in the axis travel direction

Function principle MK

Air pressure: 4.0 - 8 bar

Clamping by air pressure

In the MK, the clamping profiles are pressed against the web surfaces of the roller guide rail by pneumatic pressure acting through a dual-action tapered slide valve mechanism.

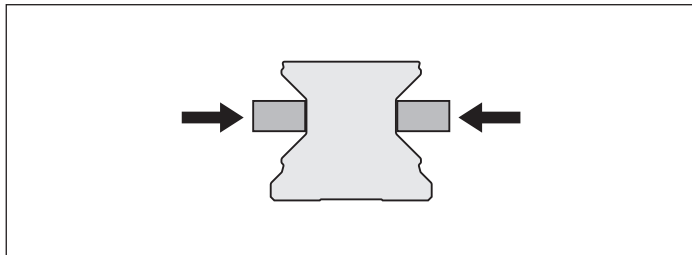

Air pressure: 0 bar

Release by spring action

A preloaded return spring provides quick release.

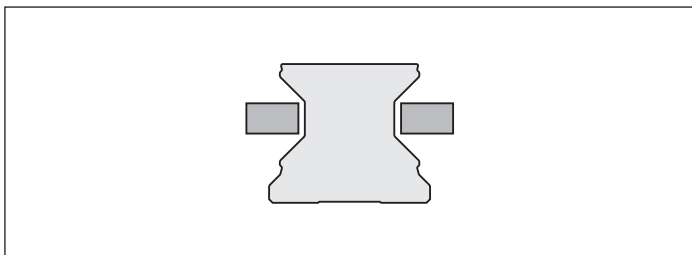

Function principle MKS

Air pressure: 0 bar

Clamping by spring action

In the event of a pressure drop, the MKS clamps via a dual-action tapered slide valve mechanism with two spring assemblies (spring energy accumulators). An integrated quick venting valve ensures fast response.

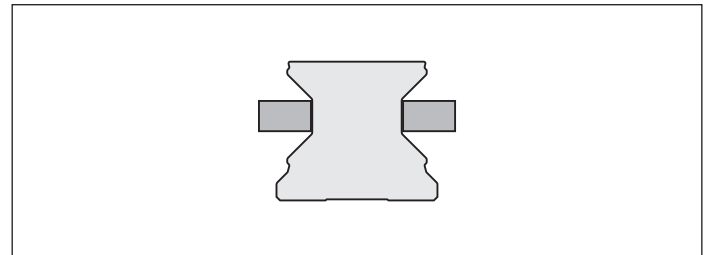

Air pressure: 5.5 - 8 bar

Release by air pressure

The clamping profiles are held apart by compressed air.

- ▶ Allows free movement

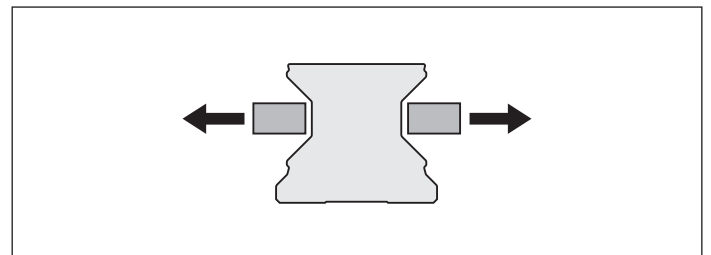

Further highlights

- ▶ Easy mounting
- ▶ Steel housing, catalytically nickel-plated
- ▶ High axial and horizontal stiffness
- ▶ Precise positioning

Special features of MK:

- ▶ Clamping by pressure (pneumatic) applied by a dual-action tapered slide valve mechanism
- ▶ Steplessly adjustable pressure from 4 - 8 bar
- ▶ Quick release
- ▶ 5 million clamping cycles (B10d value)

Special features of MKS:

- ▶ Pressureless clamping (by spring energy) via the dual-action tapered slide valve mechanism with two spring assemblies
- ▶ Release pressure 5.5 bar (pneumatic)
- ▶ Increased holding force through air-plus port
- ▶ 5 million clamping cycles (B10d value)*)

*) B10d value is not achieved on air-plus port

MK

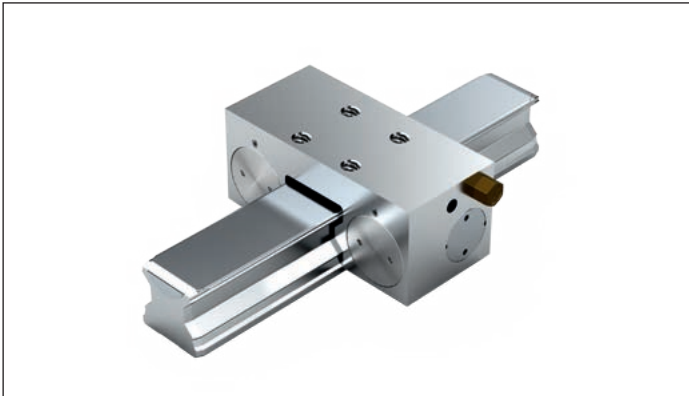

MKS

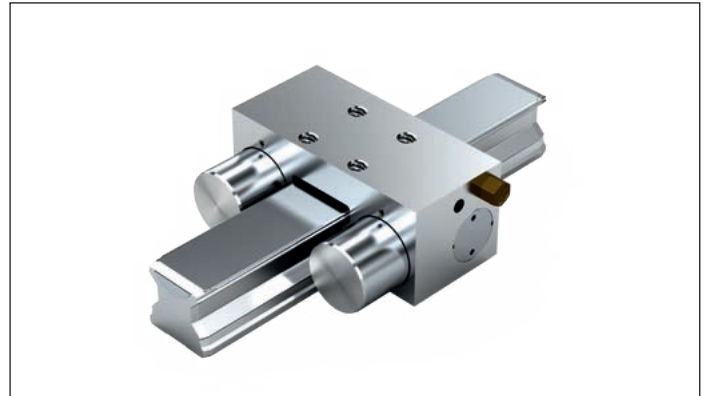

Pneumatic Clamping Units MK

R1810 .42 60



Note

- ▶ Suitable for roller guide rails SNS.

Clamping by pressure application

- ▶ Max. pneumatic operating pressure: 8 bar
- ▶ Operating temperature range t: 0 - 70 °C

Notes for mounting

- ▶ Make sure the adjoining structure is sufficiently rigid.
- ▶ Use only filtered air. The specified filter mesh size is 25 µm.
- ▶ Read the mounting instructions before start-up.

⚠ Follow the safety notes for clamping and braking units.

Circuitry for standard air port

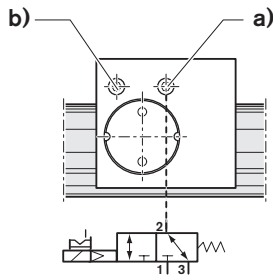

- 1 Air port
- 2 Operating ports
- 3 Venting

Technical data

Size	Part numbers	Pneumatic holding force ¹⁾ (N)	Air consumption (normalized) (dm ³ /stroke) Air port	Mass (kg)
25	R1810 242 60	1 200	0.021	0.45
30 ^{*)}				
35	R1810 342 60	2 000	0.031	0.88
45	R1810 442 60	2 250	0.041	1.70
55	R1810 542 60	2 250	0.041	1.95
65	R1810 642 60	2 250	0.041	2.68

^{*)} In preparation

¹⁾ Holding force at 6 bar. Testing is performed in the installed condition with a film of lubricating oil (ISO-VG 68).

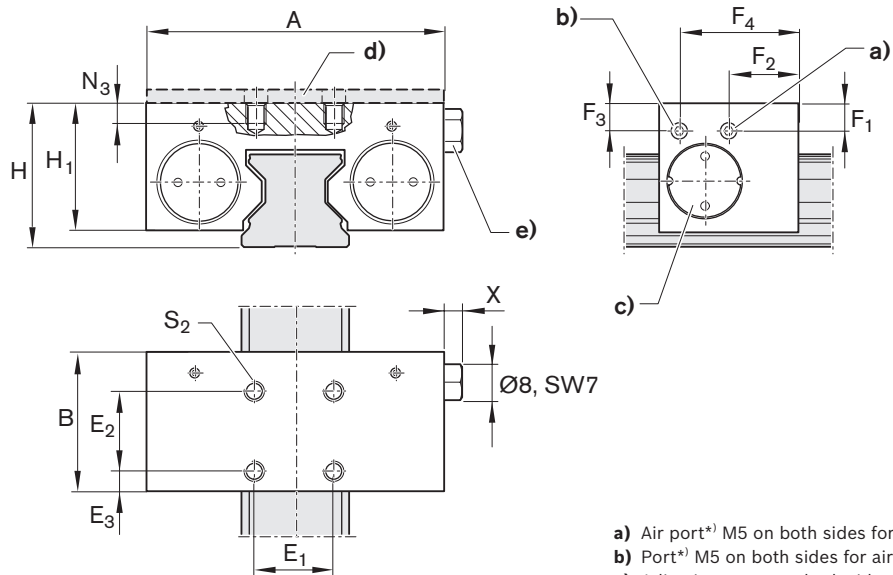

- a)** Air port^{*)} M5 on both sides for release pressure
b) Port^{*)} M5 on both sides for air filter
c) Adjusting screw on both sides
d) Spacer plate (accessory) for MK
e) Air filter: port M5 (at either side)
 *) Only one port required
 All ports are plugged for shipment.

Dimensions (mm)

Size	A	B	E ₁	E ₂	E ₃	F ₁	F ₂	F ₃	F ₄	H	H ₁ ¹⁾	N ₃	S ₂	X
25	75	35	20	20	5.0	6.5	17.5	6.5	30.0	36	32.5	8.0	M6	5.5
30^{*)}														
35	100	39	24	24	7.5	11.0	14.5	12.0	24.5	48	44.0	10.0	M8	5.5
45	120	49	26	26	11.5	14.5	19.5	14.5	29.5	60	52.0	15.0	M10	5.5
55	128	49	30	30	9.5	17.0	19.5	17.0	29.5	70	57.0	15.0	M10	5.5
65	138	49	30	30	9.5	14.5	19.5	14.5	29.5	90	73.5	20.0	M10	5.5

^{*)} In preparation

1) For roller runner block .H. (High), a spacer plate is needed.

Pneumatic Clamping Units MKS R1810 .40 60



Note

- ▶ Suitable for roller guide rails SNS.

Clamps without pressurization (spring energy)

- ▶ Release pressure min. 5.5 bar
- ▶ Max. pneumatic operating pressure: 8 bar
- ▶ Operating temperature range t: 0 - 70 °C

Notes for mounting

- ▶ Make sure the adjoining structure is sufficiently rigid.
- ▶ Use only filtered air. The specified filter mesh size is 25 µm.
- ▶ Read the mounting instructions before start-up.

⚠ Follow the safety notes for clamping and braking units.

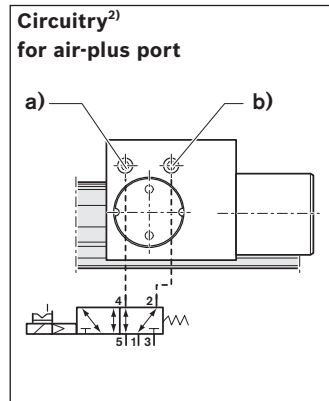
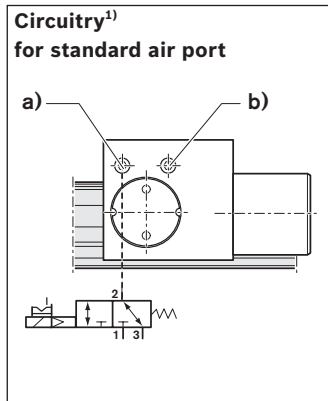

- 1 Air port
- 2 4 Operating ports
- 3 5 Venting

Technical data

Size	Part numbers	Spring energy holding force ¹⁾ (N)		Air consumption (normalized) (dm ³ /stroke)		Mass (kg)
		Air port	with air-plus port ²⁾	Air port	Air-plus port	
25	R1810 240 60	750	1 500	0.021	0.068	0.50
30 ^{*)}						
35	R1810 340 60	1 250	3 250	0.031	0.129	1.00
45	R1810 440 60	1 450	3 300	0.041	0.175	1.84
55	R1810 540 60	1 450	3 300	0.041	0.175	2.08
65	R1810 640 60	1 450	3 300	0.041	0.175	2.86

^{*)} In preparation

- 1) Holding force achieved by spring energy. Testing is performed in the installed condition with a film of lubricating oil (ISO-VG 68).
- 2) Increased holding force through additional pressurization with 6.0 bar compressed air at the air-plus port. Switching via 5/2 or 5/3-way directional control valve.

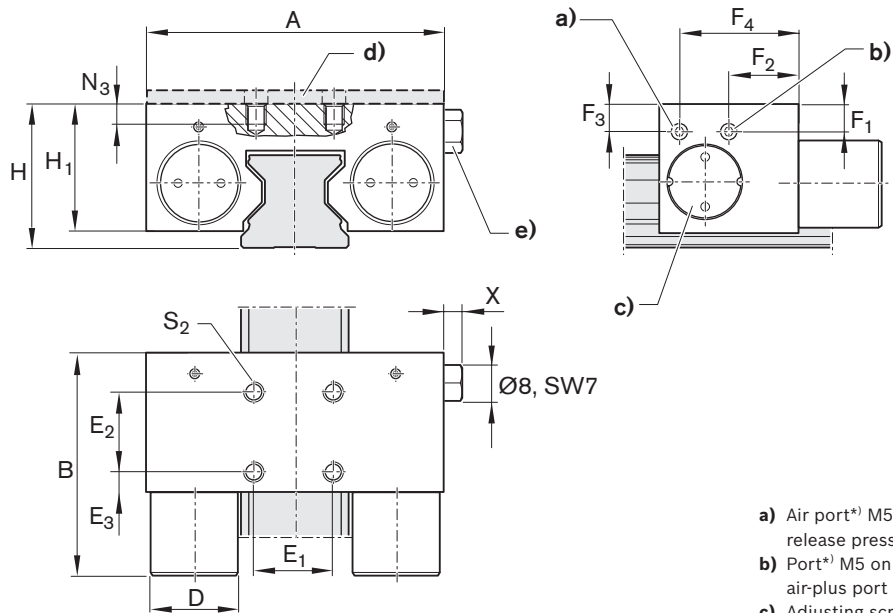

- a) Air port*) M5 on both sides for release pressure
 - b) Port*) M5 on both sides for air-plus port or air filter
 - c) Adjusting screw on both sides
 - d) Spacer plate (accessory) for MKS
 - e) Air filter: port M5 (at either side)
- *) Only one port required
All ports are plugged for shipment.

Dimensions (mm)

Size	A	A ₁	B	B _{1 max}	D	E ₁	E ₂	E ₃	F ₁	F ₂	F ₃	F ₄	H	H ₁ ¹⁾	H ₂	N ₃	S ₂	X
25	75	49.0	35	57.3	22	20	20	5.0	6.5	30.0	6.5	17.5	36	32.5	20.0	8.0	M6	5.5
30 *)																		
35	100	68.0	39	67.5	28	24	24	7.5	12.0	24.5	11.0	14.5	48	44.0	28.0	10.0	M8	5.5
45	120	78.8	49	82.5	30	26	26	11.5	14.5	29.5	14.5	19.5	60	52.0	35.5	15.0	M10	5.5
55	128	86.8	49	82.5	30	30	30	9.5	17.0	29.5	17.0	19.5	70	57.0	40.0	15.0	M10	5.5
65	138	96.8	49	82.5	30	30	30	9.5	14.5	29.5	14.5	19.5	90	73.5	55.0	20.0	M10	5.5

*) In preparation

1) For roller runner block .H. (High), a spacer plate is needed.

Manual Clamping Units, Spacer Plates

Product Description

Manual clamping units

Application areas

- ▶ Table crossbars and slides
- ▶ Width adjustment
- ▶ Mechanical stops
- ▶ Positioning on optical instruments and measuring tables

Characteristic features

- ▶ Simple, reliable construction in compact design
- ▶ Manually operated clamping unit without auxiliary power

Special feature of HK:

- ▶ 500,000 clamping cycles (B10d value)

⚠ Follow the safety notes for clamping and braking units.

Function principle HK

Pressure applied by hand lever

Clamping by manual pressure

The clamping profiles are pressed against the web surfaces of the roller guide rail by the action of the hand lever.

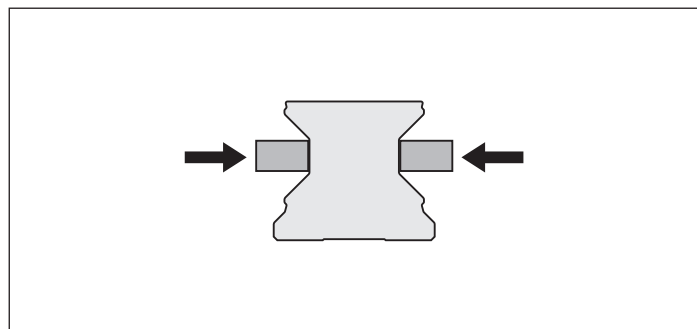

Release by disengaging the hand lever

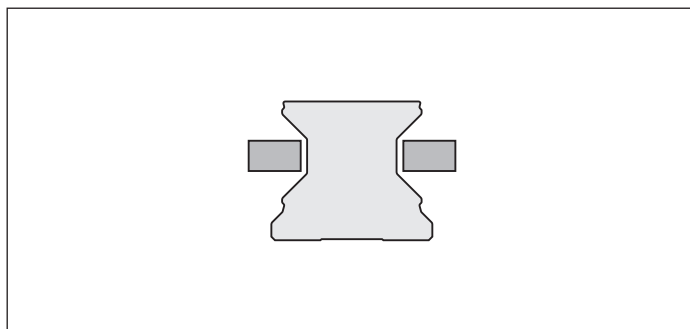

Further highlights

- ▶ Freely adjustable hand lever
- ▶ Symmetrical force application to roller guide rail via floating contact profile
- ▶ Precise positioning
- ▶ Holding forces up to 2,000 N

Manual clamping unit HK

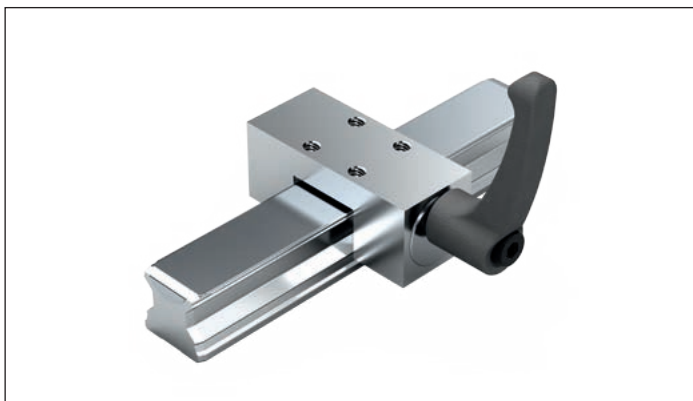

Spacer plates

Suitable for installation with roller runner block high SNH R1821 and SLH R1824

For clamping units MK, MKS and HK



Manual Clamping Unit HK

R1619 .42 82

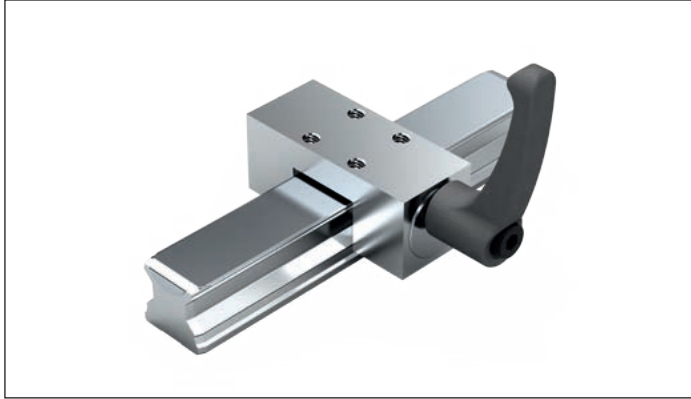

Note

Suitable for roller guide rails SNS.

Manual clamping

- ▶ Operating temperature range t: 0 - 70 °C

Notes for mounting

- ▶ Make sure the adjoining structure is sufficiently rigid.
- ▶ Read the mounting instructions before start-up.

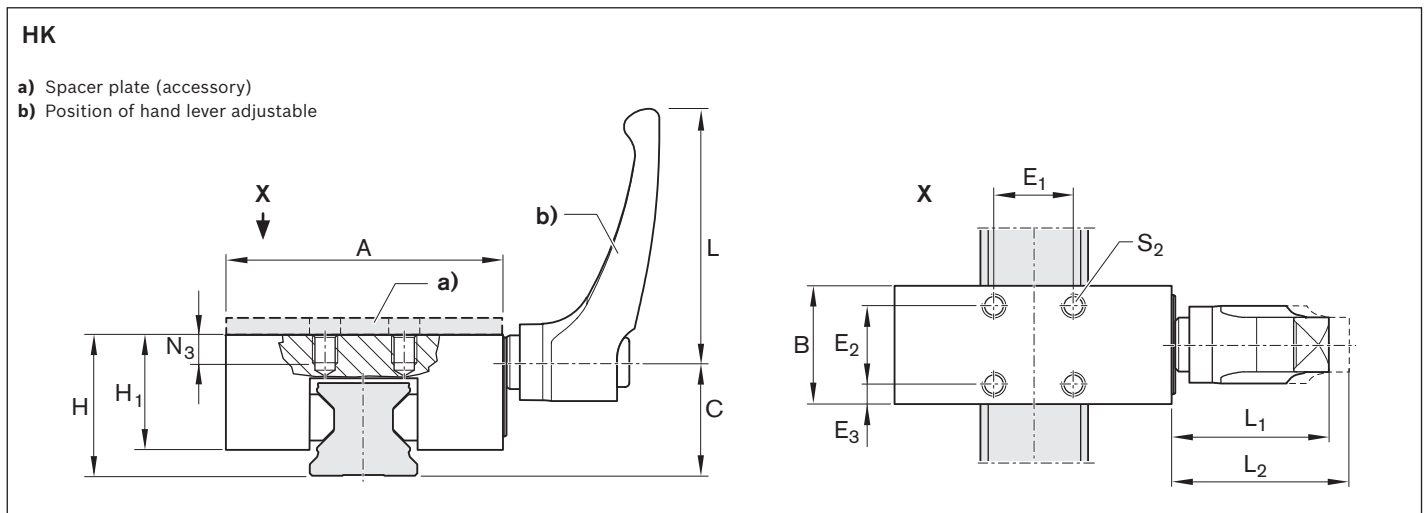

Size	Part numbers	Holding force ¹⁾ (N)	Tightening torque (Nm)
25	R1619 242 82	1 200	7
30	R1619 742 82	2 000	15
35	R1619 342 82	2 000	15
45	R1619 442 82	2 000	15
55	R1619 542 82	2 000	22
65	R1619 642 82	2 000	22

Size	Dimensions (mm)													Mass (kg)
	A	B	C	E ₁	E ₂	E ₃	H	H ₁ ³⁾	L	L ₁	L ₂ ²⁾	N ₃	S ₂	
25	70	30	29.3	20	20	5.0	36	29	64	38.5	41.5	7	M6	0.43
30	90	39	34.0	22	22	8.5	42	33	78	46.5	50.5	8	M6	0.82
35	100	39	38.0	24	24	7.5	48	41	78	46.5	50.5	10	M8	1.08
45	120	44	47.0	26	26	9.0	60	48	78	46.5	50.5	14	M10	1.64
55	140	49	56.5	30	30	9.5	70	51	95	56.5	61.5	14	M14	1.71
65	160	64	69.5	35	35	14.5	90	66	95	56.5	61.5	20	M16	2.84

1) Testing is performed in the installed condition with a film of lubricating oil (ISO-VG 68).

2) Hand lever disengaged

3) For roller runner block .H. (High), a spacer plate is needed.

Spacer Plate for MK, MKS, HK

Note

Suitable for installation with roller runner block high SNH R1821 and SLH R1824.

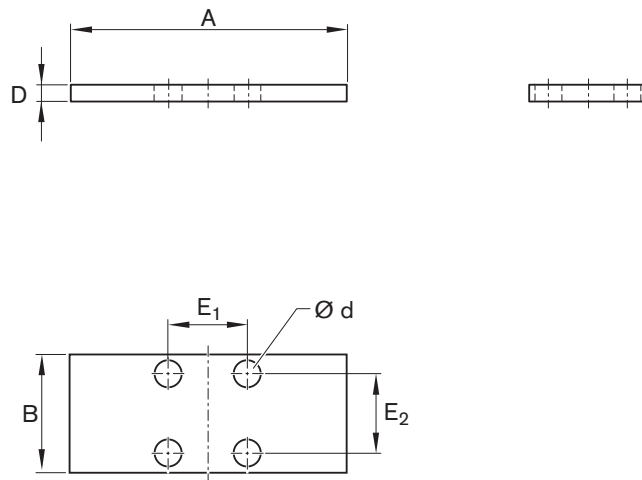
Spacer plate

R1619 .40 65
Suitable for clamping units:

- ▶ R1810 .42 60 (MK)
- ▶ R1810 .40 60 (MKS)

Part numbers and dimensions

Size	Part numbers	Dimensions (mm)						Mass (kg)
		A	B	D	d	E ₁	E ₂	
25	R1619 240 65	75	35	4	6.5	20	20	0.078
30	R1619 740 65	90	39	3	8.5	22	22	0.077
35	R1619 340 65	100	39	7	8.5	24	24	0.202
45	R1619 440 65	120	49	10	10.5	26	26	0.434
55	R1619 540 65	128	49	10	10.5	30	30	0.465

R1619 .42 .5
Suitable for clamping units:

- ▶ R1619 .42 82 (HK)

Part numbers and dimensions

Size	Part numbers	Dimensions (mm)						Mass (kg)
		A	B	D	d	E ₁	E ₂	
25	R1619 242 85	70	30	4	6.5	20	20	0.062
30	R1619 742 85	90	39	3	6.5	22	22	0.080
35	R1619 340 65	100	39	7	8.5	24	24	0.202
45	R1619 442 85	120	44	10	10.5	26	26	0.387
55	R1619 542 85	140	49	10	14.5	30	30	0.511

General Mounting Instructions

General notes

The following installation notes apply to all Roller Rail Systems.

Rexroth Roller Rail Systems are high-grade quality products. Particular care must be taken during transportation and subsequent mounting. The same care must be taken with cover strips.

All steel parts are protected with anti-corrosion oil. It is not necessary to remove this oil, provided that the recommended lubricants are used.

⚠ In overhead mounting orientations (suspended top down) the roller runner block could possibly come away from the guide rail due to loss or breakage of rollers. Secure the roller runner block against falling!

Parallelism offset of the installed rails

Values measured at the guide rails and at the roller runner blocks

The parallelism offset P_1 causes a slight increase in preload on one side of the assembly.

As long as the values specified in the table are met, the effect of parallelism offsets on the service life can generally be neglected.

Preload classes

C1, C2, C3

Mounting with mounting runner block

The central hole D in the mounting runner block allows precise measurement of the relative rail position. The rail mounting screws can also be driven down through this hole.

Aligning the rails

1. Align and mount the first guide rail using a graduated straightedge.
2. Set up a mounting bridge with dial gauge between the roller runner blocks.
3. Move both roller runner blocks in parallel until hole D in the mounting runner block is positioned precisely above a mounting hole in the rail.
4. Align the guide rail manually until the dial gauge shows the correct dimension.
5. Then screw down the rail through hole D in the mounting runner block.

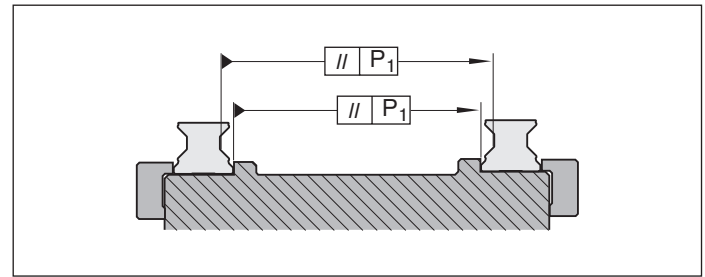

Roller rail system	Size	Parallelism offset P_1 (mm) for preload class	
		C2	C3
Standard	25	0.007	0.005
	30	0.009	0.006
	35	0.010	0.007
	45	0.012	0.009
	55	0.016	0.011
	65	0.022	0.016
Wide	55/85	0.016	0.011
	65/100	0.022	0.016
Heavy duty	65FXS	0.022	0.016
	100	0.029	0.022
	125	0.034	0.026

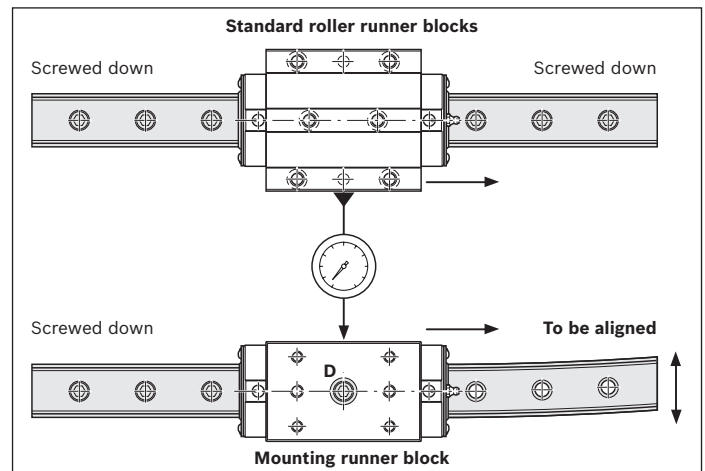

Vertical offset

Provided the vertical offset is kept within the stated tolerances for S_1 and S_2 , its influence on the service life is generally negligible.

Permissible vertical offset in the transverse direction S_1

The tolerance for dimension H, as given in the table with accuracy classes in the “General Product Description” section, must be deducted from the permissible vertical offset S_1 of the roller guide rails.

Permissible vertical offset in the longitudinal direction S_2

The tolerance “max. difference in dimensions H on the same rail”, as given in the table with accuracy classes in the “General Product Description” section, must be deducted from the permissible vertical offset S_2 of the roller runner blocks.

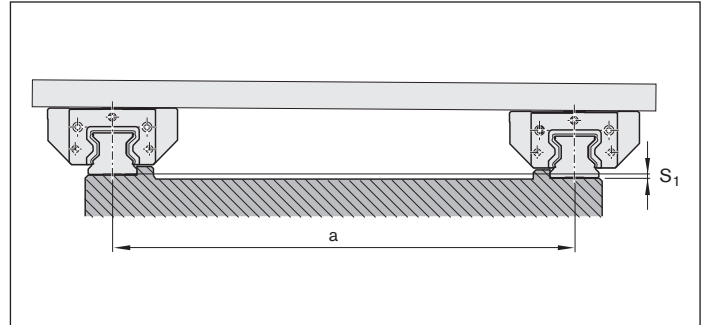

Calculation factor	for preload class	
	C2	C3
Y	$1.7 \cdot 10^{-4}$	$1.2 \cdot 10^{-4}$

$$S_1 = a \cdot Y$$

S_1 = permissible vertical offset of the guide rails (mm)
 a = distance between guide rails (mm)
 Y = calculation factor

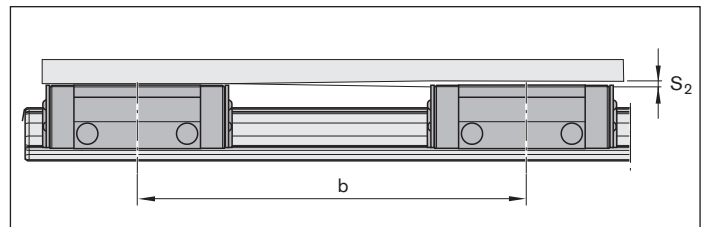

Calculation factor	for runner block length		
	Normal	Long	Extra long
X	$4.3 \cdot 10^{-5}$	$3.0 \cdot 10^{-5}$	$2.2 \cdot 10^{-5}$

$$S_2 = b \cdot X$$

S_2 = permissible vertical offset of the runner blocks (mm)
 b = distance between runner blocks (mm)
 X = calculation factor

Roller runner block normal

- ▶ Standard roller rail system FNS R1851, SNS R1822, SNH R1821
- ▶ Heavy duty roller rail system FNS R1861

Roller runner block long

- ▶ Standard roller rail system FLS R1853, SLH R1824, SLS R1823
- ▶ Wide roller rail system BLS R1872
- ▶ Heavy duty roller rail system FLS R1863

Roller runner block extra long

- ▶ Heavy duty roller rail system FLS R1854

General Mounting Instructions

Delivery of the roller guide rails

One-piece roller guide rails

Standard: One-piece roller guide rails with cover strip are shipped with the cover strip clipped on, both ends angled down and with protective end caps screwed on.

If required, roller guide rails can also be supplied with a separate cover strip.

Composite roller guide rails

The cover strip and protective end caps are supplied complete with screws and washers in a separate packing unit. The packing unit is marked with the same manufacturing job number as the labels on the roller guide rails.

The cover strips have one angled down and one straight end (strip tongue).

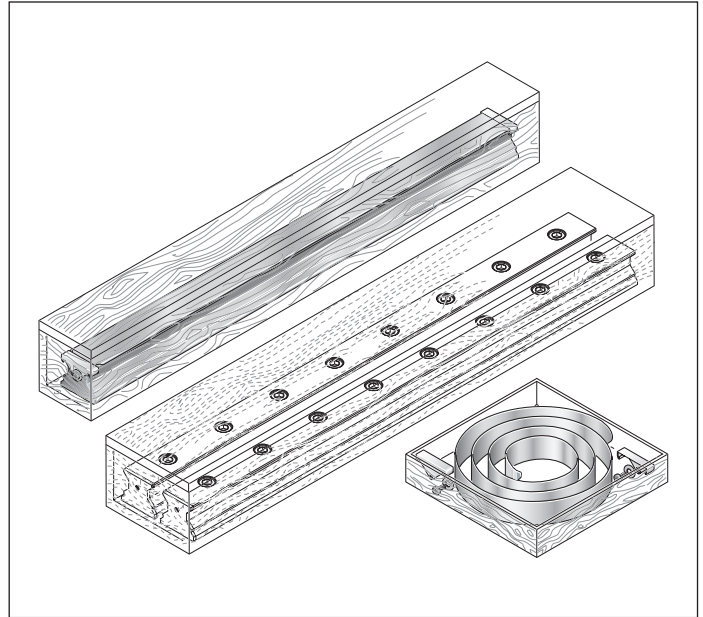

Composite roller guide rails

Matching sections of a composite roller guide rail are identified as such by a label on the packaging. All sections of the same rail have the same serial rail number. The numbering is marked on the top of the roller guide rail.

Note on cover strip

For composite roller guide rails, a one-piece cover strip to cover the total length L is supplied separately.

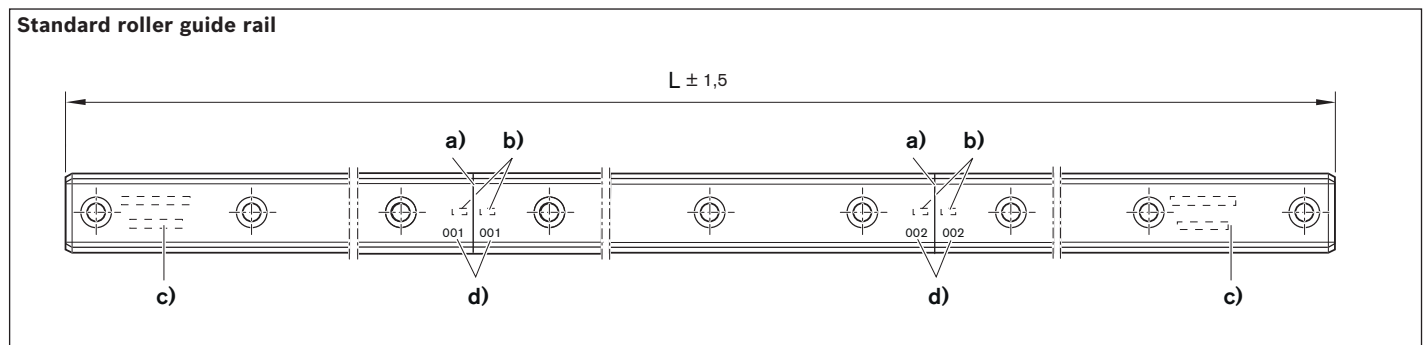

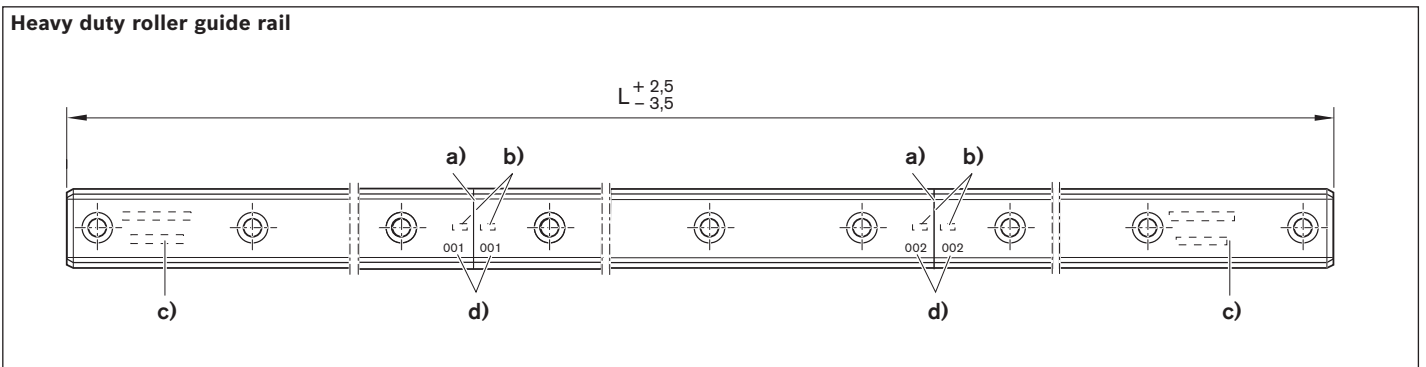
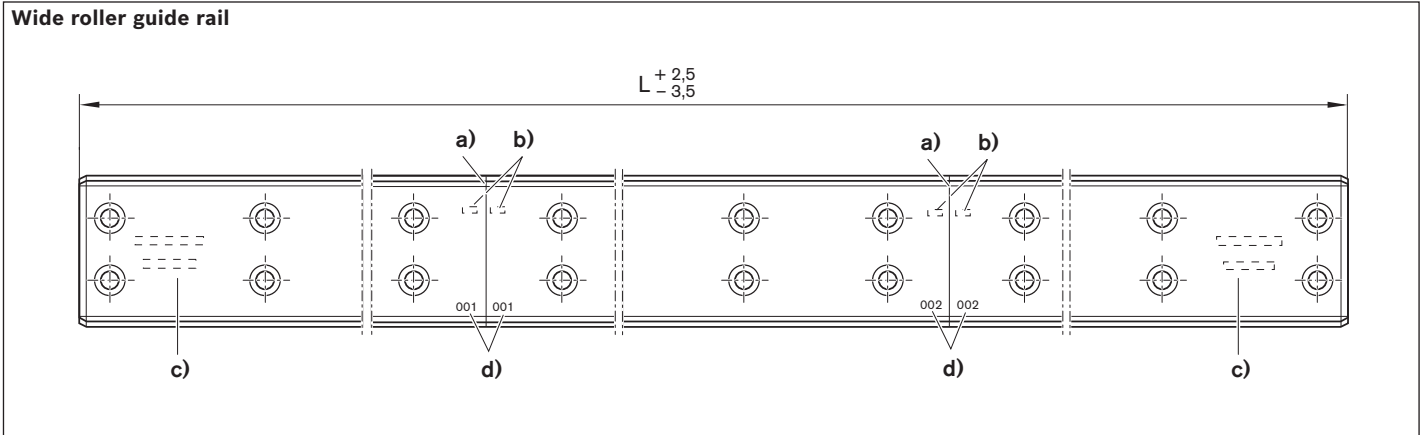

- a) Joint (sharp-edged, now also in hard chrome plated roller guide rails)
- b) Rail number
- c) Full rail identification on first and last sections
- d) Joint number

Note on adjoining structure

Permissible hole position tolerances on the mounting holes for the adjoining structure

Size	Hole position tolerance (mm)
25 - 35	∅ 0.2
45 - 100	∅ 0.3
125	∅ 0.6

Adjusting shaft

The sections of composite roller guide rails can be aligned with the aid of an adjusting shaft. For more detailed information see “Accessories” and “Mounting Instructions for Roller Rail Systems.”

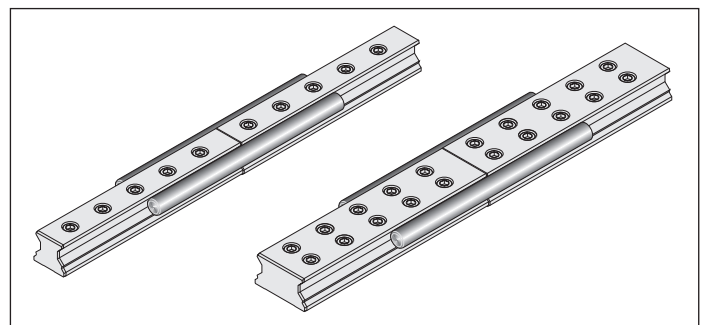

General Mounting Instructions

Mounting examples

Roller guide rails

Each roller guide rail has ground reference surfaces on both sides. These are not marked, since each roller guide rail can be mounted to the left or the right of a reference edge (1) for lateral retention.

Notes

- ▶ For roller guide rails without lateral retention, we recommend using a straightedge to make sure the rails are properly aligned and parallel during assembly (recommended limits for side load if no additional lateral retention is provided, see “Fastening”).
- ▶ Use a mounting runner block (see “General Mounting Instructions”).
- ▶ Install mounting hole plugs or a cover strip (see the relevant Mounting Instructions)!

- A** After mounting the roller guide rails, tap the plastic mounting hole plugs into the screw holes with the aid of a plastic pad until flush with the surface of the rail.
- B** To fit steel mounting hole plugs, always use the special mounting tool (see “Accessories”). Equalize any difference in height between roller guide rails. Only then can the roller runner blocks be mounted.
- C** For roller guide rails with cover strip, see “Notes on cover strip.”

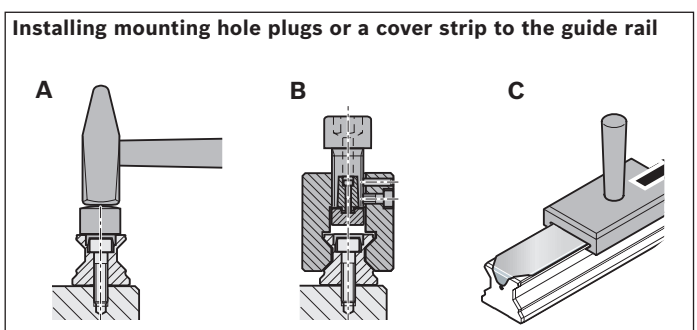
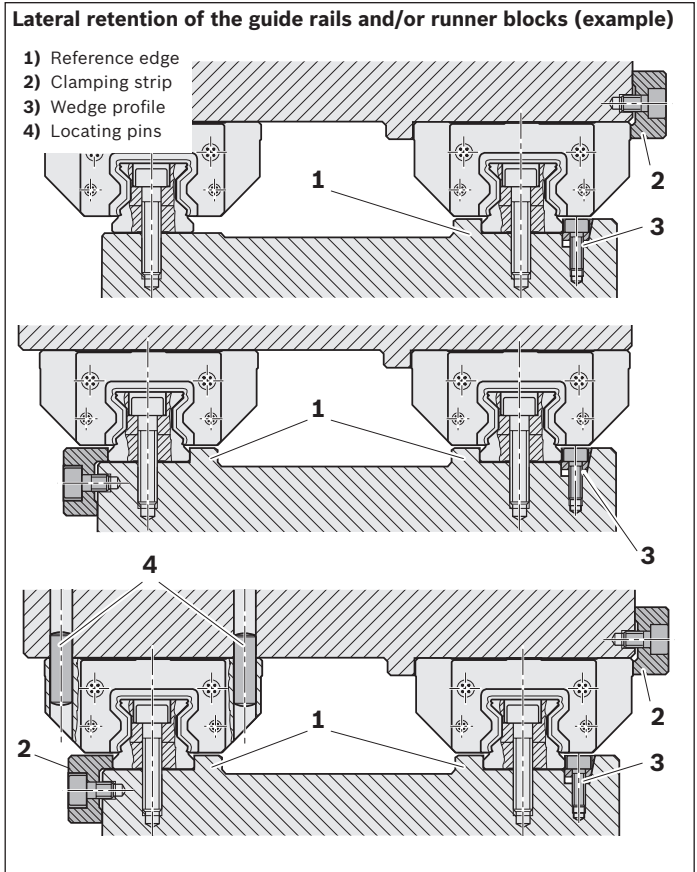

Roller runner blocks

Standard and heavy duty roller runner blocks have one ground reference edge (1) on each side, while wide roller runner blocks have two (total of four) (dimension V_1 in the dimension drawings).

- ⚠ Always fit steel mounting hole plugs before pushing on the roller runner blocks! Before mounting the runner block, oil or grease the sealing lips of the runner block and the bevel on the end face of the roller guide rail!
- ▶ After sliding the roller runner block onto the rail, check that it moves easily.
- ⚠ Then apply initial lubrication (see “Lubrication” section)!
- ▶ Detailed information on the mounting procedure can be found in “Mounting Instructions for Roller Rail Systems.”

- ⚠ The roller runner block must remain on the arbor (mounting aid) until it is slid onto the roller guide rail! Otherwise, rollers may be lost!

- ⚠ Use the arbor if the roller runner block is removed from the roller guide rail!
When not installed on the rails, the roller runner blocks should always be kept on the arbor!

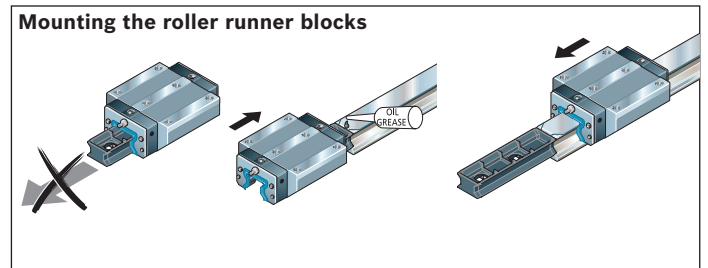

Fastening

Calculating threaded connections

The threaded connections in runner block and guide rail produce maximum traction forces $F_{0z \max}$, maximum static torsional moments $M_{0x \max}$ and maximum static side load $F_{0y \max}$ without stop strips that the linear guide can transfer. The maximum load on a profiled guide rail is defined not only by the static load-bearing capacity C_0 in accordance with ISO 14728 Part 2 and the static moments M_{t0} from the rolling contact, but also by the threaded connections.

As a rule runner blocks are fastened using 4 or 6 screws. Roller guide rails have one or two rows of threaded connections at regular intervals, whereby the screws located directly under the runner block are subject to the most stress. If the runner block and rail are fastened with screws in the same strength class, the connection between the rail and the mounting base (O_3) is critical to the maximum forces and moments that can be transferred.

The values in the table for strength class 8.8 are taken from DIN 637 (August 2013): Rolling bearings – Safety regulations for dimensioning and operation of profiled rail systems with recirculating rolling elements. Threaded connections with strength classes 10.9 and 12.9 are calculated based on the dimensions in the catalog (screw sizes, block lengths, clamping lengths, screw-in depths, bore diameters, rail hole distribution, rail width, etc.). Refer to VDI 2230 when recalculating other threaded connections. The maximum static traction force and maximum static torsional moment of a roller rail system are the product of the sum of the axial forces on the rail screws within the flow of forces. However, for the maximum static side load, the sum of the clamping forces on the rail screws within the flow of forces is crucial.

Input values:

- | | |
|---------------------------------------|------------------|
| – Friction coefficient in thread | $\mu_G = 0.125$ |
| – Friction coefficient on top surface | $\mu_K = 0.125$ |
| – Friction coefficient in joint | $\mu_T = 0.125$ |
| – Torque wrench tightening factor | $\alpha_A = 1.5$ |

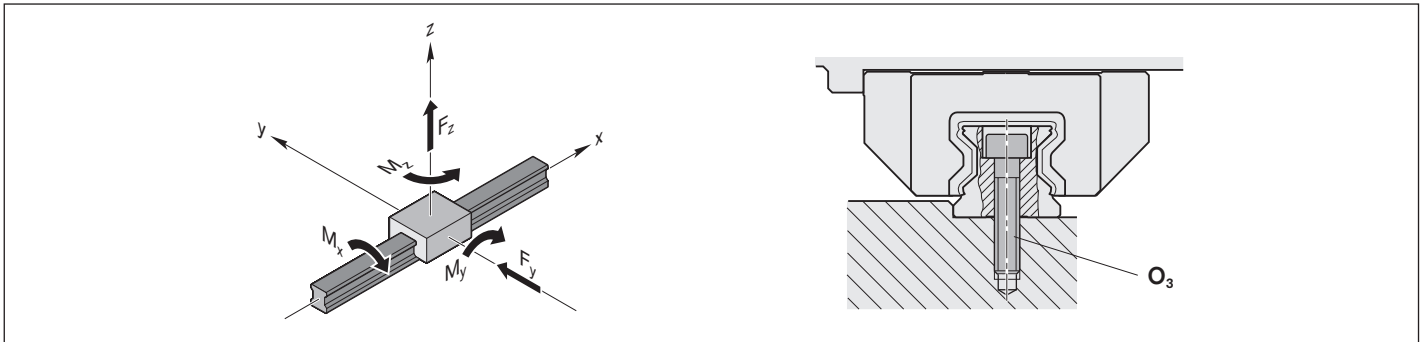

Maximum static traction forces and torsional moments on profiled rail systems (as per DIN 637)



The threaded connections in a profiled rail system can only transfer a limited traction force F_z or a limited torsional moment M_x . If these limit values are exceeded, the guide will lift off of the adjacent structure or the threaded connection will fail. The maximum values for a guide are the product of the maximum possible axial force on a threaded connection in the guide rail. The specified maximum static load should not be exceeded.

The table values are guidelines for the maximum static traction force $F_{0z \max}$ and torsional moments $M_{0x \max}$ that are only applicable when the following conditions are met:

- Screw sizes, screw quantity and connecting dimensions as listed in the catalog
- Same mounting screw strength class for blocks and rails
- Steel adjacent structure
- Traction force F_z or torsional moment M_x are static
- Traction force F_z and torsional moment M_x do not occur simultaneously
- No interaction with side load F_y or longitudinal moment M_y/M_z

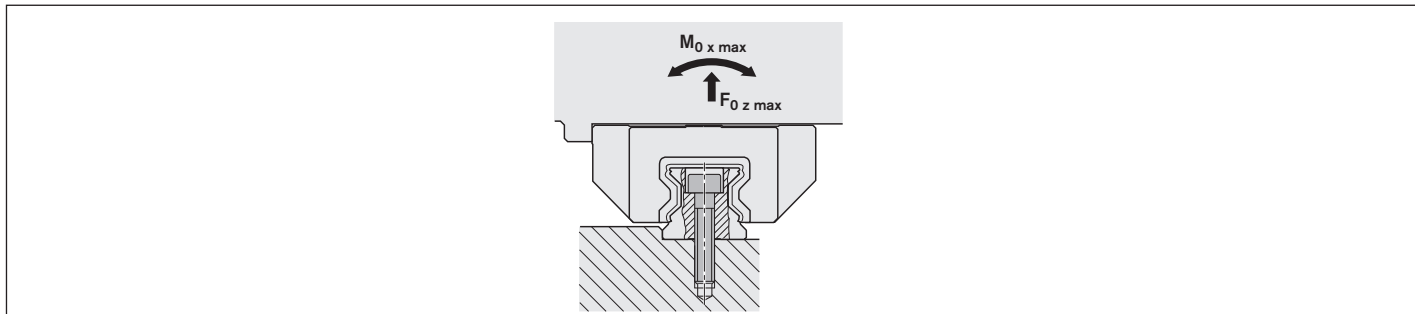
If these conditions are not met, recalculate the threaded connection in accordance with VDI 2230. If the applied loads are just below the limit values, Bosch Rexroth also recommends checking the threaded connections.

Roller rail systems

Size	Standard length 		Long 	
	$F_{0z \max}$ (N)	$M_{0x \max}$ (Nm)	$F_{0z \max}$ (N)	$M_{0x \max}$ (Nm)

Strength class 8.8 (as per DIN 637)

25	18 800	200	21 500	230
30 ^{*)}				
35	36 900	590	42 200	680
45	91 700	1 900	104 800	2 200
55	127 400	3 200	145 600	3 600
65	176 400	5 200	201 700	6 000
100	419 400	19 700	479 300	22 500
125	677 700	39 800	774 500	45 500
55/85			216 000	6 060
65/100			296 000	9 900

Strength class 10.9 (calculated with Rexroth roller rail system dimensions)

25	31700	330	36300	380
30 ^{*)}				
35	57000	910	65100	1040
45	140000	3000	159000	3430
55	193000	4820	220000	5510
65	267000	8010	305000	9150
100	612000	29700	699000	33900
125	980000	58800	1120000	67200
55/85			305000	8560
65/100			419000	14000

Strength class 12.9 (calculated with Rexroth roller rail system dimensions)

25	37900	400	43400	460
30 ^{*)}				
35	67800	1080	77500	1240
45	165000	3550	189000	4060
55	228000	5690	260000	6500
65	315000	9440	360000	10800
100	719000	34900	822000	39900
125	1151000	69100	1315000	78900
55/85			360000	10100
65/100			494000	16500

*) In preparation

Fastening

Maximum static side load without stop strips (as per DIN 637)

For a secure structure, Rexroth recommends using stop strips on the runner block and guide rail. If stop strips are not used on the runner block or the rail, then if a load is applied in the transverse direction the guide may slip. The clamping force on the threaded connection is too low as soon as the side loads in the table are exceeded.





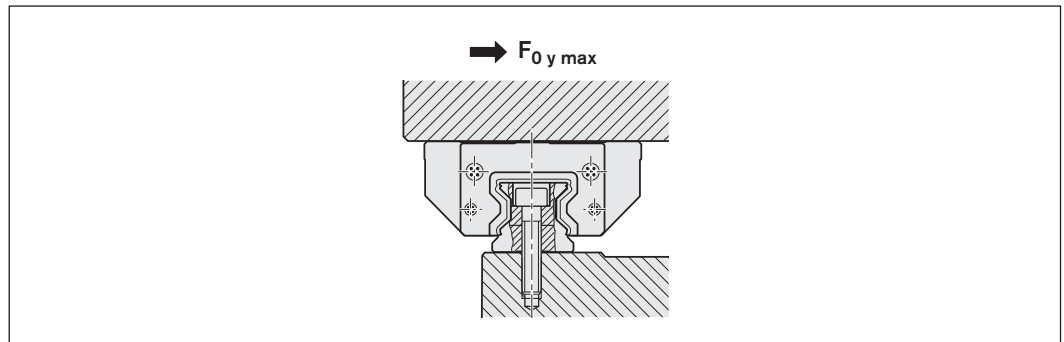

The table values are guidelines for the maximum static side loads $F_{0y \max}$ that are only applicable when the following conditions are met:

- Screw sizes, screw quantity and connecting dimensions as listed in the catalog
- Same mounting screw strength class for blocks and rails
- Steel adjacent structure
- No interaction with traction force F_z , torsional moments M_x or longitudinal moments M_y/M_z

If these conditions are not met, recalculate the threaded connection in accordance with VDI 2230. If the applied loads are just below the limit values, Bosch Rexroth also recommends checking the threaded connections.



Roller rail systems

Size	Strength class					
	8.8		10.9		12.9	
	Standard length	Long	Standard length	Long	Standard length	Long
						
	$F_{0y \max}$ (N)	$F_{0y \max}$ (N)	$F_{0y \max}$ (N)	$F_{0y \max}$ (N)	$F_{0y \max}$ (N)	$F_{0y \max}$ (N)
25	1400	1600	2230	2550	2660	3040
30^{*)}						
35	2800	3200	4210	4820	5010	5730
45	6900	7900	10000	11500	11900	13600
55	9600	10900	14000	16000	16500	18900
65	13200	15100	19400	22100	22800	26100
100	31500	36000	44200	50500	52000	59400
125	50800	58100	71200	81400	83700	95600
55/85		26400		37800		44600
65/100		42500		60800		71700

*) In preparation

Tightening torques for profiled rail systems (as per DIN 637)

The tightening torques for screw strength class 8.8 correspond to DIN 637. The tightening torques for screw strength classes 10.9 and 12.9 were calculated for the dimensions of a Rexroth roller rail system.

	Tightening torques M_A (Nm) for strength class		
	8.8	10.9	12.9
M6	10	15	17
M8	25	36	43
M10	49	71	83
M12	83	120	140
M14	130	190	230
M16	200	300	350
M20	410	590	690
M24	700	1000	1170
M27	1040	1480	1740
M30	1400	1990	2330

Fastening

Reference edges and corner radii

Combination examples

The combinations shown here are examples. Basically, any roller runner block may be combined with any of the roller guide rail types offered.

Mounting and lubrication

For details of roller runner block and roller guide rail mounting, see “General Mounting Instructions.”
 For initial and in-service lubrication, see “Lubrication.”
 Detailed information on the mounting procedure can be found in “Mounting Instructions for Roller Rail Systems.”

Standard roller rail systems

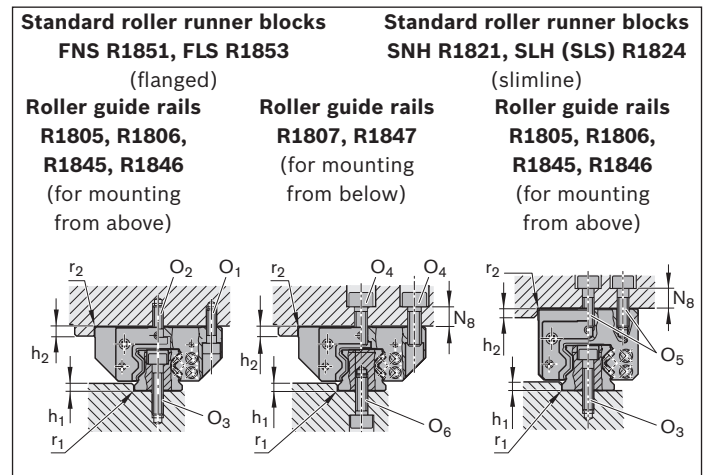

Size	Dimensions (mm)					
	$h_{1 \min}$	$h_{1 \max}^{1)}$	h_2	N_8	$r_{1 \max}$	$r_{2 \max}$
25	3.0	4.5	5	10	0.8	0.8
30 ^{*)}						
35	3.5	5.0	6	13	0.8	0.8
45	4.5	7.0	8	14	0.8	0.8
55	7.0	9.0	10	20	1.2	1.0
65	7.0	9.0	14	22	1.2	1.0

*) In preparation

1) When using clamping and braking units, please take account of the values H_1 .

Mounting screws

⚠ Always check the strength factor of the screws in the case of high lift-off loads!

Size	Screw sizes					
	Roller runner blocks				Roller guide rails	
	O_1	$O_2^{1)}$	$O_4^{1)2)}$	O_5	O_3	O_6
	ISO 4762 4 pcs	DIN 6912 2 pcs	ISO 4762 6 pcs	ISO 4762 6 pcs	ISO 4762	ISO 4762
25	M6x20	M6x16	M8x20	M6x18	M6x30	M6x20
30 ^{*)}						
35	M8x25	M8x20	M10x25	M8x25	M8x35	M8x25
45	M10x30	M10x25	M12x30	M10x30	M12x45	M12x30
55	M12x40	M12x30	M14x40	M12x35	M14x50	M14x40
65	M14x45	M14x35	M16x45	M16x40	M16x60	M16x45

*) In preparation

- For fixing of the roller runner block with 6 screws:
Tighten the middle screws (O_2 , O_4) to a tightening torque for strength class 8.8
- For fixing of the roller runner block from above with only 4 O_4 screws:
Permissible side load 1/3 lower, and lower rigidity

Locating pins

⚠ If the recommended limits for permissible side loads are exceeded, the roller runner block must be additionally fixed!

Possible pin types

- ▶ Taper pin (hardened) or
- ▶ Straight pin ISO 8734

Notes

Rough-drilled holes made for production reasons may exist at the recommended pin hole positions on the runner block centerline ($\varnothing < S_{10}$). These may be bored open to accommodate the locating pins.

If the locating pins have to be driven in at another point, dimension E_2 must not be exceeded in the longitudinal direction (for dimension E_2 , see the tables for the individual runner block types).

Observe dimensions E_1 and E_4 !

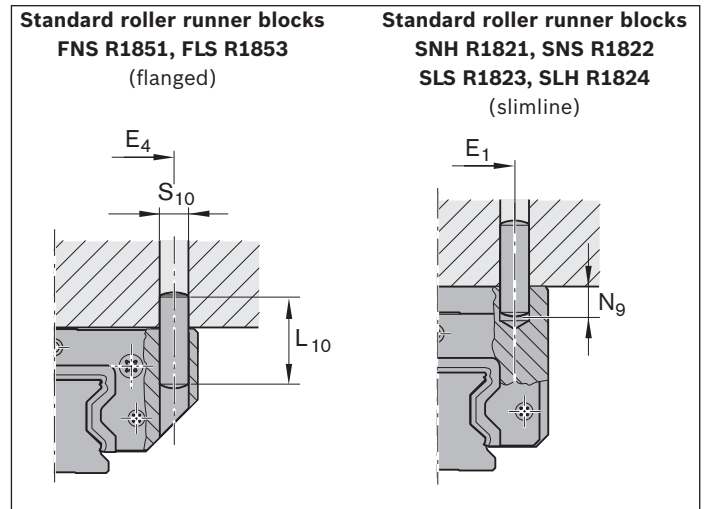

Size	Dimensions (mm)				
	E_1	E_4	$L_{10}^{1)}$	$N_{9 \max}$	$S_{10}^{1)}$
25	35	55	32	9	6
30 ^{*)}					
35	50	80	40	13	8
45	60	98	50	18	10
55	75	114	60	19	12
65	76	140	60	22	14

*) In preparation

1) Taper pin (hardened) or straight pin (ISO 8734)

Fastening

Reference edges and corner radii

Mounting and lubrication

For details of roller runner block and roller guide rail mounting, see “General Mounting Instructions.”

For initial and in-service lubrication, see “Lubrication.” Detailed information on the mounting procedure can be found in “Mounting Instructions for Roller Rail Systems.”

Wide roller rail systems

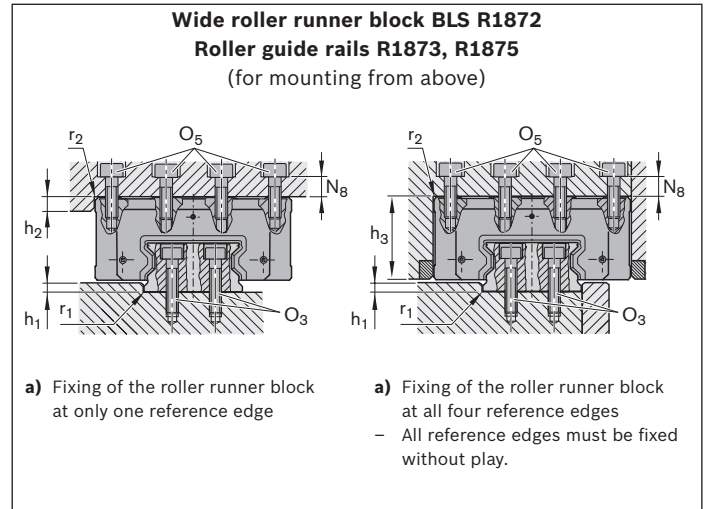

Size	Dimensions (mm)						
	$h_{1 \min}$	$h_{1 \max}$	h_2	h_3	N_8	$r_{1 \max}$	$r_{2 \max}$
55/85	7.0	9.0	10	84	14	1.2	1.0
65/100	7.0	9.0	14	66.5	20	1.2	1.0

Mounting screws

⚠ Always check the strength factor of the screws in the case of high lift-off loads!

Size	Screw sizes	
	Roller runner blocks	Roller guide rails
	O₅ ISO 4762 6 pcs	O₃ ISO 4762
55/85	M12x50	M12x30
65/100	M14x60	M14x35

Reference edges and corner radii

Mounting and lubrication

For details of roller runner block and roller guide rail mounting, see “General Mounting Instructions.”

To facilitate the mounting of heavy duty roller runner blocks on the rail, a mounting aid is available on request (see “Accessories”).

For initial and in-service lubrication, see “Lubrication.”

Detailed information on the mounting procedure can be found in “Mounting Instructions for Roller Rail Systems.”

Heavy-duty roller rail systems

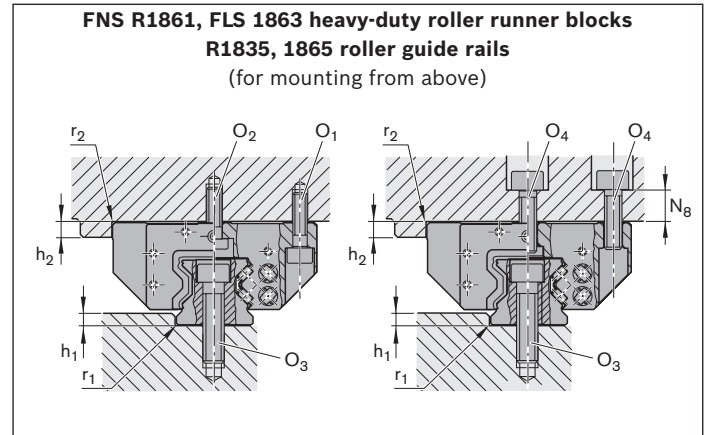

Size	Dimensions (mm)					
	$h_{1 \min}$	$h_{1 \max}$	h_2	N_8	$r_{1 \max}$	$r_{2 \max}$
100	10	14	18	30	1.8	1.3
125	15	20	23	40	1.8	1.8

Mounting screws

⚠ Always check the strength factor of the screws in the case of high lift-off loads!

Size	Screw sizes			
	Roller runner blocks			Roller guide rails
	O_1 ISO 4762 6 pcs	$O_2^{1)}$ DIN 6912 3 pcs	$O_4^{1) 2)}$ ISO 4762 9 pcs	O_3 ISO 4762
100	M16x60	M16x55	M20x60	M24x100
125	M24x85	M24x70	M27x80	M30x120

- 1) For fixing of the roller runner block with 9 screws:
Tighten the centerline screws O_2 or O_4 along the roller guide rail with the tightening torque for strength class 8.8
- 2) For fixing of the roller runner block from above with only 6 O_4 screws:
Permissible side load 1/3 lower, and lower rigidity

Lubrication Notes

- The service life of the roller rail systems crucially depends on the lubrication. For this purpose, the documentation, especially the chapter on lubrication, must be read and understood completely.
- The operator is responsible for the selection and adequate supply of an appropriate lubricant to the roller rail system. These instructions do not exempt the operator from the individual examination of the conformity and suitability of the lubricant for its application.
- For recommended lubricants, see the chapter “Notes on Dynalub”.
- Rexroth roller rail systems are delivered filled with an anti-corrosion agent (sufficient for mounting and start-up).
- Immediately after mounting the roller runner blocks (before start-up), make sure the system has sufficient initial lubrication (basic lubrication). All roller runner blocks are designed for both grease lubrication and for oil lubrication.

⚠ To safeguard the supply of lubricant the lube ports from the “Accessories” section are to be used. On the usage of different lube ports attention is to be paid to ensuring they are identical to Rexroth lube ports (M6 x 8).

⚠ If using a progressive lubrication system, with grease lubrication, please pay attention to the minimum dosing amount for relubrication stated in table 5.

⚠ We recommend carrying out initial lubrication separately using a grease gun before connecting to the central lubrication system.

If using a central lubrication system, you must make sure that all the pipes and elements are filled with lubricant and do not contain any air pockets until they are connected to the consumer (roller runner block).

The number of pulses results from the partial amounts and the piston distributor size.

▶ **With fluid grease lubrication according to table 5**

▶ **With oil lubrication according to table 8**

⚠ The seals on the roller runner block must be oiled or greased with the respective lubricant before installation.

⚠ If you use different lubricants from the ones stated, you may find that relubrication intervals are shorter and that performance decreases with short stroke and load ratio; in addition, chemical interactions can take place between the plastics, lubricants and the preservative agents. In addition, pumpability in single-line central lubrication systems must be guaranteed.

⚠ Pumping or storage tanks for the lubricant must be fitted with a stirrer to guarantee the flow of lubricant (to avoid funneling in the tank).

⚠ You must not use lubricants containing solid lubricating components (like graphite and MoS₂ for example)!

⚠ In the case of relubrication, it is not possible to change from grease to oil lubrication.

⚠ When applying metalworking fluids at the start or after a relatively long standstill, carry out two to five lubrication pulses in succession. When the system is in operation, 3 to 4 pulses per hour are recommended, irrespective of the distance traveled. If possible, carry out lubrication in one lubricating stroke. Carry out cleaning cycles (see “Maintenance”). The user alone is responsible for selecting suitable metalworking fluids. An unfavorable selection of metalworking fluids may lead to damage to the roller rail system. We recommend getting in touch with the manufacturer of the metalworking fluids. Bosch Rexroth accepts no liability. Lubricant and metalworking fluids must be coordinated.

⚠ In the case of environmental influences such as contamination, vibration, jolting, etc., we recommend shortening the relubrication intervals appropriately. Even under normal operating conditions, the system must be relubricated at the latest after 2 years due to aging of the grease.

- If your application involves more demanding environmental requirements (such as clean room, vacuum, food industry applications, increased exposure to fluids or aggressive media, extreme temperatures), please consult us. Each application must be considered on its own merits in order to choose the most appropriate lubricant. Be sure to have all the information concerning your application at hand when contacting us. Pay attention to the chapter “Maintenance”.
- Rexroth recommends piston distributors manufactured by SKF. These should be installed as close as possible to the lube ports of the roller runner blocks. Long lines and small line diameters should be avoided, and the lines should be laid on an upward slant. Install the lines at a gradient.
- Refer to the chapter entitled “Roller runner block accessories” for a selection of possible lube ports (in this connection, contact the manufacturer of your lubrication system too).
- If other consumers are connected to the single-line centralized lubrication system, the weakest link in the chain will determine the lubrication cycle time.

Note on load ratio

The load ratio F/C is the quotient of the equivalent dynamic load on the bearing F (making allowance for the preload C) divided by the dynamic load capacity C (see “General Technical Data and Calculations”).

Notes on Dynalub

 Pay attention to the assignment of the roller rail system.

Under conventional environmental conditions this ground-fiber, homogeneous grease is ideally suited for the lubrication of linear elements:

- ▶ With loads up to 50% C
- ▶ With short-stroke applications > 1 mm
- ▶ For the permissible speed range of roller rail systems

The product and safety data sheets can be found on our website at: www.boschrexroth.com.

Dynalub 510

Lubricating grease

Properties:

- ▶ Lithium-based, high-performance grease of NLGI grade 2 according to DIN 51818 (KP2K-20 according to DIN 51825)
- ▶ Good water resistance
- ▶ Corrosion protection
- ▶ Temperature range: -20 to $+80$ °C

Material numbers for Dynalub 510:

- ▶ R3416 037 00 (cartridge 400 g)
- ▶ R3416 035 00 (hobcock 25 kg)

Alternative greases:

- ▶ Castrol Longtime PD2 or Elkalub GLS 135/N2

Notes on lubricant oil

We recommend **Shell Tonna S3 M 220** or similar products with the following properties:

- ▶ Special demulsifying oil CLP or CGLP as per DIN 51517-3 for machine bed tracks and tool guides
- ▶ A blend of highly refined mineral oils and additives
- ▶ Can be used even when mixed with significant quantities of metalworking fluids

Dynalub 520

Liquid grease

Properties:

- ▶ Lithium-based, high-performance grease of NLGI grade 00 according to DIN 51818 (GP00K-20 according to DIN 51826)
- ▶ Good water resistance
- ▶ Corrosion protection
- ▶ Temperature range: -20 to $+80$ °C

Material numbers for Dynalub 520:

- ▶ R3416 043 00 (cartridge 400 g)
- ▶ R3416 042 00 (bucket 5 kg)

Alternative greases:

- ▶ Castrol Longtime PD00 or Elkalub GLS 135/N00

Lubrication of the RSHP

Lubrication using a grease gun or a progressive feeder system

⚠ Take note of “Lubrication Notes” section.

Lubricating grease

We recommend using **Dynalub 510**. For further information, see “Lubrication Notes” section.

Lube port end cap

L = left

R = right

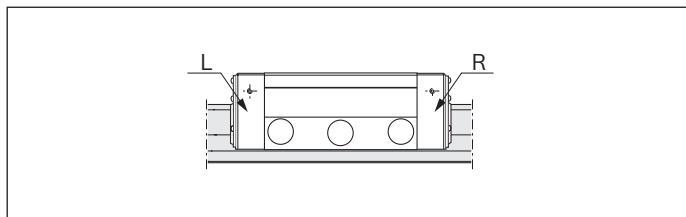

Initial lubrication of the roller runner blocks (basic lubrication)

Stroke $\geq 2 \cdot$ roller runner block length B_1 (normal stroke)

- For initial lubrication, mount one lube fitting per roller runner block, at either of the two end caps!

Initial lubrication is applied in three partial quantities as specified in Table 1:

1. Grease the roller runner block with the first partial quantity as per Table 1, pressing it in slowly with the help of a grease gun.
2. Slide the roller runner block back and forth over at least three times the block length for three full cycles.
3. Repeat steps 1. and 2. twice more.
4. Make sure there is a visible film of lubricant on the roller guide rail.

Stroke $< 2 \cdot$ roller runner block length B_1 (short stroke)

- Install and lubricate two lube fittings per roller runner block, one on each of the two end caps!

Initial lubrication is applied to each fitting in three partial quantities as specified in Table 1:

1. Grease each fitting on the roller runner block with the first partial quantity as per Table 1, pressing it in slowly with the help of a grease gun.
2. Slide the roller runner block back and forth over at least three times the block length for three full cycles.
3. Repeat steps 1. and 2. twice more.
4. Make sure there is a visible film of lubricant on the roller guide rail.

Size	Initial lubrication quantity		
	Normal stroke Partial quantity (cm ³)	Short stroke Partial quantity per port (cm ³)	
		L	R
25 ^{*)}			
30 ^{*)}			
35	0,9 (3x)	0,9 (3x)	0,9 (3x)
45	1,0 (3x)	1,0 (3x)	1,0 (3x)
55	2,5 (3x)	2,5 (3x)	2,5 (3x)
65	2,7 (3x)	2,7 (3x)	2,7 (3x)

Table 1

^{*)} Values in preparation

Relubrication of roller runner blocks

Stroke $\geq 2 \cdot$ roller runner block length B_1 (normal stroke)

- ▶ When the travel distance shown as the relubrication interval in Fig. 1 has been reached, apply the relubrication quantity as specified in Table 2.

Stroke $< 2 \cdot$ roller runner block length B_1 (short stroke)

- ▶ When the travel distance shown as the relubrication interval in Fig. 1 has been reached, apply the relubrication quantity as specified in Table 2.
- ▶ During each lubrication cycle the roller runner block should be traversed through a lubricating stroke of $3 \cdot$ roller runner block length B_1 . In any case, the lubricating stroke must be at least the length B_1 of the roller runner block.

Size	Relubrication quantity		
	Normal stroke (cm ³)	Short stroke per port (cm ³)	
		L	R
25*)			
30*)			
35	0.9	0.9	0.9
45	1.0	1.0	1.0
55	2,5	2,5	2,5
65	2,7	2,7	2,7

Table 2

*) Values in preparation

Lubrication cycle time calculations

$f_{kSS} = 1$ (no exposure to metalworking fluids)

$f_{kSS} = 5$ (exposure to metalworking fluids)

$$S_T = s \cdot \frac{1}{f_{kSS}}$$

Load-dependent relubrication intervals

The following conditions apply:

- ▶ Maximum speed: $v_{max} = 4$ m/s
- ▶ No exposure to metalworking fluids
- ▶ Standard seals
- ▶ Ambient temperature: $T = 10 - 40$ °C

Key to graphs

s = relubrication interval expressed as travel (km)
 C = dynamic load capacity (N)
 F = equivalent dynamic load (N)
 S_T = lubrication cycle for the application
 f_{kSS} = metalworking fluids correction factor

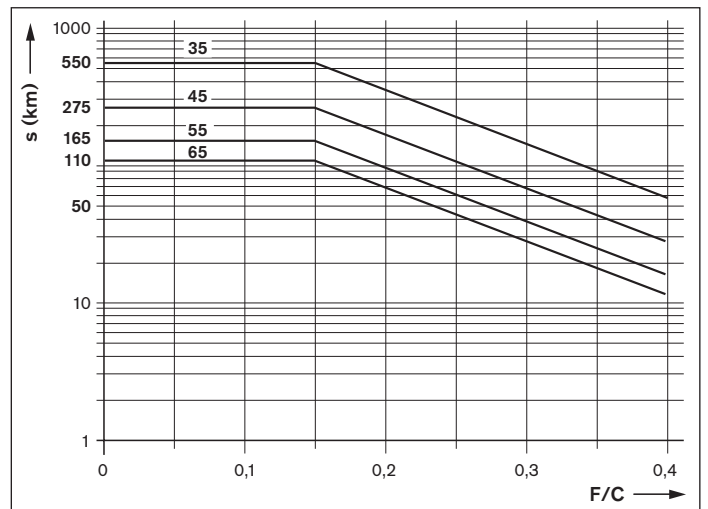

Fig. 1: Relubrication interval

Lubrication of the RSHP

Liquid grease lubrication (NLGI 00, with centralized lubrication system via piston distributor)

▲ Take note of “Lubrication Notes” section.

Liquid grease

We recommend using **Dynalub 520**. For further information, see “Lubrication Notes” section.

Lube port end cap

L = left, R = right

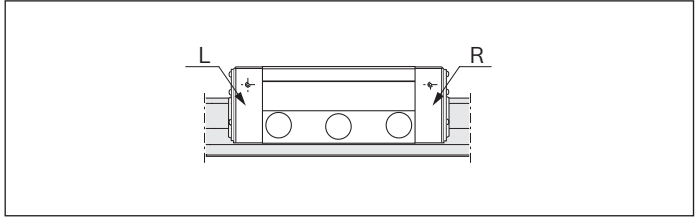

Initial lubrication of the roller runner blocks (basic lubrication)

We recommend applying initial lubrication with a manual grease gun before connecting the equipment to the centralized lubrication system. If initial lubrication is nevertheless carried out via the centralized lubrication system, it is essential that all lines and piston distributors should be filled. The pulse count can then be calculated from the partial quantities according to Table 3 and the piston distributor size according to Table 5.

Stroke $\geq 2 \cdot$ roller runner block length B_1 (normal stroke)

► For initial lubrication, mount one lube fitting per roller runner block, at either of the two end caps!

Initial lubrication is applied in three partial quantities as specified in Table 3:

1. Grease the roller runner block with the first partial quantity as per Table 3, pressing it in slowly with the help of a grease gun.
2. Slide the roller runner block back and forth over at least three times the block length for three full cycles.
3. Repeat steps 1. and 2. twice more.
4. Make sure there is a visible film of lubricant on the roller guide rail.

Stroke $< 2 \cdot$ roller runner block length B_1 (short stroke)

► Install and lubricate two lube fittings per roller runner block, one on each of the two end caps!

Initial lubrication is applied to each fitting in three partial quantities as specified in Table 3:

1. Grease each fitting on the roller runner block with the first partial quantity as per Table 3, pressing it in slowly with the help of a grease gun.
2. Slide the roller runner block back and forth over at least three times the block length for three full cycles.
3. Repeat steps 1. and 2. twice more.
4. Make sure there is a visible film of lubricant on the roller guide rail.

Size	Initial lubrication quantity		
	Normal stroke Partial quantity (cm ³)	Short stroke Partial quantity per port (cm ³)	
		L	R
25 ^{*)}			
30 ^{*)}			
35	0.9 (3x)	0.9 (3x)	0.9 (3x)
45	1.0 (3x)	1.0 (3x)	1.0 (3x)
55	2,5 (3x)	2,5 (3x)	2,5 (3x)
65	2,7 (3X)	2,7 (3X)	2,7 (3X)

Table 3

^{*)} Values in preparation

Relubrication of roller runner blocks

Stroke $\geq 2 \cdot$ roller runner block length B_1 (normal stroke)

- ▶ Apply the minimum quantity according to Table 4 to the lube port until the relubrication interval as specified (in Fig. 2) has been reached.

Stroke $< 2 \cdot$ roller runner block length B_1 (short stroke)

- ▶ Apply the minimum quantity according to Table 4 per lube port until the relubrication interval as specified (in Fig. 2) has been reached. Calculate the required pulse count and lubricant cycle time in the same way as for relubrication (normal stroke).
- ▶ During each lubrication cycle the roller runner block should be traversed through a lubricating stroke of $3 \cdot$ roller runner block length B_1 . In any case, the lubricating stroke must be at least the length B_1 of the roller runner block.

Notes: The required pulse count is the quotient (as a whole number) of the minimum relubrication quantity according to Table 4 and the selected piston distributor size according to Table 5. The smallest permissible piston distributor size is independent of the mounting orientation. The lubricant cycle time as per Formula 1 can then be obtained by dividing the relubrication interval (according to Fig. 2) by the calculated pulse count (see design calculation example).

Lubrication cycle time calculations

- $f_{KSS} = 1$ (no exposure to metalworking fluids)
- $f_{KSS} = 5$ (exposure to metalworking fluids)

Size	Relubrication quantity		
	Normal stroke (cm ³)	Short stroke per port (cm ³)	
		L	R
25*)			
30*)			
35	0.9	0.9	0.9
45	1.0	1.0	1.0
55	2,5	2,5	2,5
65	2,7	2,7	2,7

Table 4

*) Values in preparation

$$n_i = V_{Grease} / K_v$$

$$S_T = s \cdot \frac{1}{f_{KSS}} \cdot \frac{1}{n_i}$$

Formula 1

Load-dependent relubrication intervals

The following conditions apply:

- ▶ Maximum speed: $v_{max} = 4$ m/s
- ▶ No exposure to metalworking fluids
- ▶ Standard seals
- ▶ Ambient temperature: $T = 10 - 40$ °C

Key to graphs

- n_i = number of pulses (-)
- V_{Grease} = relubrication quantity according to Table 4 (cm³)
- K_v = piston distributor size according to Table 5 (cm³)
- s_T = lubrication cycle (km)
- s = relubrication interval according to Fig. 2 (km)
- C = dynamic load capacity (N)
- F = equivalent dynamic load (N)
- S_T = lubrication cycle for the application
- f_{KSS} = metalworking fluids correction factor

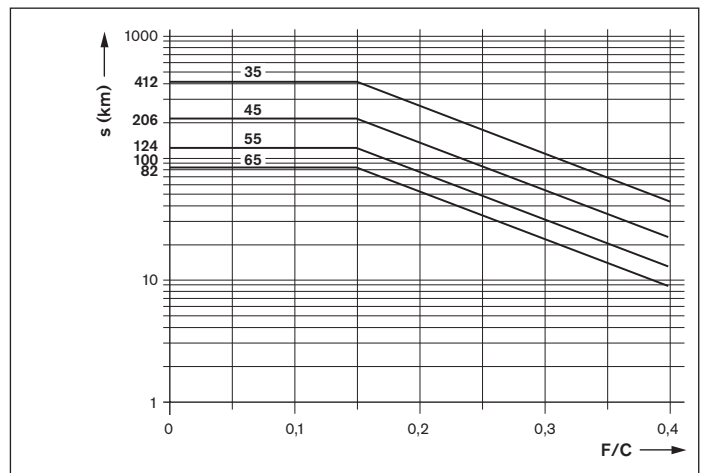

Fig. 2: Relubrication interval

Part number Roller runner blocks	Smallest permissible piston distributor size (≙ minimum pulse quantity) per port (cm ³)						
	Size	25	30	35	45	55	65
R18 2X		-	-	0,1	0,1	0,1	0,2

Table 5

Liquid grease lubrication (NLGI 00, with centralized lubrication system via piston distributor) (continued)

Calculation example:

Given data:

Roller runner block	1851 323 2X
Dynamic load capacity C	61,000 N
Equivalent dynamic load on bearing F	18,300 N
Stroke	500 mm
Average linear speed v_m	1.0 m/s
Temperature T	20 – 30 °C
Mounting orientation	horizontal
Lubrication	Single-line centralized lubrication system for all axes with liquid grease Dynalub 520
Exposure to contaminants	No exposure to fluids, chips, dust

Calculation of relubrication quantity:

Normal or short-stroke	Normal stroke	Stroke $\geq 2 \cdot$ roller runner block length B_1 500 mm $\geq 2 \times 79.6$ mm 500 mm ≥ 159.2 mm i.e. normal stroke is applicable
Initial lubrication quantity	0.90 cm ³ (3x)	According to Table 3
Relubrication quantity	$V_{\text{Grease}} = 0.90 \text{ cm}^3$	According to Table 4
Permissible piston distributor size	$K_v = 0.1 \text{ cm}^3$	According to Table 5
Number of pulses	$n_i = V_{\text{Grease}} / K_v = 0.90 \text{ cm}^3 / 0.1 = 9$	According to Formula 1
Load ratio	$F/C = 18,300 \text{ N} / 61,000 \text{ N} = 0.30$	
Relubrication interval	$s = 100 \text{ km}$	According to Fig. 2
Lubrication cycle	$s_r = s / n_i = 100 \text{ km} / 9 = 11.11 \text{ km}$	According to Formula 1
Exposure to contaminants	$s_T = s \cdot \frac{1}{1} \cdot \frac{1}{9}$	No exposure to media: Chips, dust...

Result:

Every 11.10 km a minimum quantity of 0.1 cm³ Dynalub 520 must be supplied to the roller runner block.

Lubrication of the RSHP

Oil lubrication via single-line piston distributor systems

⚠ Take note of “Lubrication Notes” section.

Oil lubricant

We recommend using **Shell Tonna S3 M 220**. For further information, see “Lubrication Notes” section.

Lube port end cap

L = left

R = right

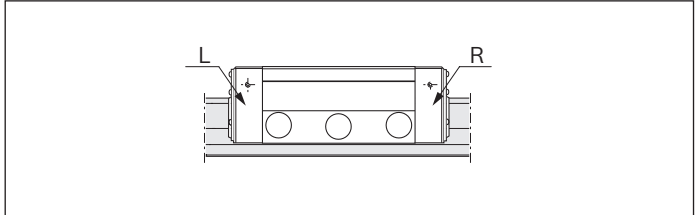

Initial lubrication of the roller runner blocks (basic lubrication)

We recommend applying initial lubrication with a manual grease gun before connecting the equipment to the centralized lubrication system. If initial lubrication is nevertheless carried out via the centralized lubrication system, it is essential that all lines and piston distributors should be filled.

Stroke $\geq 2 \cdot$ roller runner block length B_1 (normal stroke)

- For initial lubrication, mount one lube fitting per roller runner block, at either of the two end caps!

Initial lubrication is applied in two partial quantities as specified in Table 6:

1. Oil the roller runner block with the first partial quantity as per Table 6.
2. Slide the roller runner block back and forth over at least three times the block length for three full cycles.
3. Repeat steps 1. and 2.
4. Make sure there is a visible film of lubricant on the roller guide rail.

Stroke $< 2 \cdot$ roller runner block length B_1 (short stroke)

- Install and lubricate two lube fittings per roller runner block, one on each of the two end caps!

Initial lubrication is applied in two partial quantities per lube fitting as specified in Table 6:

1. Oil the roller runner block per port with the first partial quantity as per Table 6.
2. Slide the roller runner block back and forth over at least three times the block length for three full cycles.
3. Repeat steps 1. and 2.
4. Make sure there is a visible film of lubricant on the roller guide rail.

Size	Initial lubrication quantity		
	Normal stroke Partial quantity (cm ³)	Short stroke Partial quantity per port (cm ³)	
		L	R
25 ^{*)}			
30 ^{*)}			
35	1,3 (2x)	1,3 (2x)	1,3 (2x)
45	1,5 (2x)	1,5 (2x)	1,5 (2x)
55	2,0 (2x)	2,0 (2x)	2,0 (2x)
65	4,0 (2x)	4,0 (2x)	4,0 (2x)

Table 6

^{*)} Values in preparation

Relubrication of roller runner blocks

Stroke $\geq 2 \cdot$ roller runner block length B_1 (normal stroke)

- ▶ Apply the minimum quantity according to Table 7 to the lube port until the relubrication interval as specified has been reached.

Stroke $< 2 \cdot$ roller runner block length B_1 (short stroke)

- ▶ Install and lubricate two lube fittings per roller runner block, one on each of the two end caps.
- ▶ Apply the minimum quantity according to Table 7 to the lube port until the relubrication interval as specified has been reached. Calculate the actual quantity applied as described in Relubrication (normal stroke), and if necessary adjust the piston distributor size and/or cycle time.
- ▶ During the lubrication cycle the roller runner block should be traversed through a lubricating stroke of $3 \cdot$ roller runner block length B_1 . In any case, the lubricating stroke must be at least the length B_1 of the roller runner block.

Notes: The actual amount applied in the relubrication interval is calculated taking into account the average speed, the piston distributor selected and the cycle time according to Formula 2. The quantity calculated must be greater than or equal to the relubrication quantity according to Table 7. Should this amount be lower, either the cycle time must be reduced and/or a larger piston distributor selected. The calculation process according to Formula 2 is then to be repeated.

Calculation of relubrication quantity

- $f_{KSS} = 1$ (no exposure to metalworking fluids)
- $f_{KSS} = 5$ (exposure to metalworking fluids)

Calculation of the relubrication interval for the application

Load-dependent relubrication intervals

The following conditions apply:

- ▶ Maximum speed: $v_{max} = 4$ m/s
- ▶ No exposure to metalworking fluids
- ▶ Standard seals
- ▶ Ambient temperature: $T = 10 - 40$ °C

Key to graphs

- V_{Oil} = relubrication quantity applied in the relubrication interval (cm³)
- V_{min} = relubrication quantity (cm³)
- s = relubrication interval according to Fig. 3 (km)
- K_v = piston distributor size according to Table 8 (cm³)
- V_m = average linear speed (including waiting times) (m/s)
- t_T = cycle time for the centralized lubrication system (min)
- C = dynamic load capacity (N)
- F = equivalent dynamic load (N)
- S_{AP} = relubrication interval for the application
- f_{KSS} = metalworking fluids correction factor

Size	Relubrication quantity V_{min}		
	Normal stroke (cm ³)	Short stroke per port (cm ³)	
		L	R
25*)			
30*)			
35	1.3	1.3	1.3
45	1.5	1.5	1.5
55	2.0	2.0	2.0
65	4.0	4.0	4.0

Table 7

*) Values in preparation

$$V_{Oil} = \text{round} \frac{16.67 \cdot S_{AP} \cdot K_v}{v_m \cdot t_T} \geq V_{min} \text{ according to Table 7}$$

$$S_{AP} = s \cdot \frac{1}{f_{KSS}}$$

Formula 2

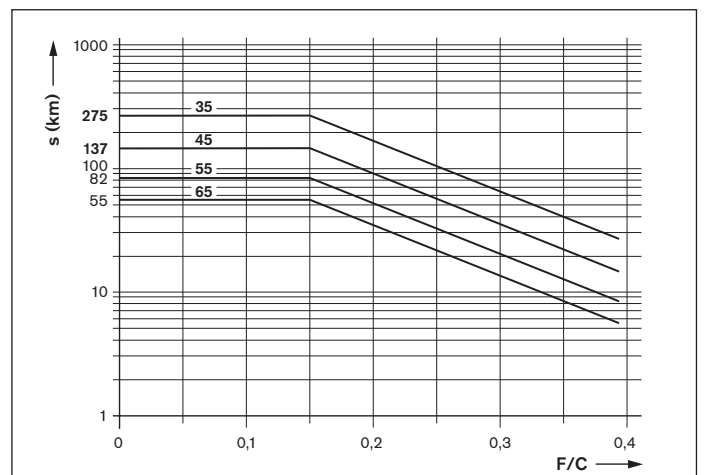









Fig. 3: Relubrication interval

Lubrication of the RSHP

Oil lubrication via single-line piston distributor systems (continued)

Roller runner block size	35				45			
Mounting orientation								
Cycle time (min)	Permissible piston distributor size (cm ³)							
Up to 30	0.06	0.06	0.10	0.10	0.10	0.10	0.16	
30 to 60	0.10	0.10	0.20	0.20	0.16	0.16	0.40	
60 to 90	0.16	0.16	0.40	0.40	0.20	0.20	0.40	
90 to 120	0.20	0.20	0.40	0.40	0.40	0.40	0.40	
> 120	0.40	0.40	0.40	0.40	0.40	0.40	0.40	









Roller runner block size	55				65			
Mounting orientation								
Cycle time (min)	Permissible piston distributor size (cm ³)							
Up to 30	0.16	0.16	0.20	0.20	0.20	0.20	0.40	
30 to 60	0.20	0.20	0.40	0.40	0.40	0.40	0.60	
60 to 90	0.40	0.40	0.60	0.60	0.60	0.60	1.00	
90 to 120	0.60	0.60	0.60	0.60	1.00	1.00	1.00	
> 120	0.60	0.60	0.60	0.60	1.00	1.00	1.00	

Table 8

On the usage of lube ports that are not offered by Rexroth for usage on the RSHP, an extension is imperative for all mounting orientations.

Mounting orientations:

 horizontal

 horizontal, top-down

 vertical

 wall attachment

Calculation example:

Given data:

Roller runner block	1851 323 2X
Dynamic load capacity C	61,000 N
Equivalent dynamic load on bearing F	18,300 N
Stroke	500 mm
Average linear speed v_m	1.0 m/s
Temperature T	20 – 30 °C
Mounting orientation	Horizontal
Lubrication	Single-line centralized lubrication system for all axes with oil Shell Tonna S3 M 220
Cycle time for the centralized lubrication system t_T	20 min
Exposure to contaminants	Exposure to metalworking fluids

Calculation of relubrication quantity:

Normal or short-stroke	Normal stroke	Stroke $\geq 2 \cdot$ roller runner block length B_1 500 mm $\geq 2 \times 79.6$ mm 500 mm ≥ 159.2 mm i.e. normal stroke is applicable
Initial lubrication quantity	1.30 cm ³ (2x)	According to Table 6
Relubrication quantity	$V_{Oil} = 1.30$ cm ³	According to Table 7
Piston distributor size	$K_v = 0.06$ cm ³	According to Table 8
Load ratio	$F/C = 18,300$ N/61,000 N = 0.30	
Relubrication interval on exposure to metalworking fluids	$S_{AP} = 60$ km $\cdot \frac{1}{f_{KSS}} = 60$ km $\cdot \frac{1}{5} = 12$ km	According to Fig. 3
Relubrication quantity applied in the relubrication interval:	$V_{Oil} = \text{round} \frac{16.67 \cdot S_{AP} \cdot K_v}{v_m \cdot t_T}$ $V_{Oil} = \text{round} \frac{16.67 \cdot 12 \cdot 0.06}{1.0 \cdot 20} = 0.6$ cm ³	According to Formula 2

Result:

The lubrication design with a piston distributor of 0.06 cm³ is **inadequate**, as the necessary relubrication quantity according to Table 7 of 1.30 cm³ is not applied during the relubrication interval. The calculation is to be repeated with a larger piston distributor.

New piston distributor size selected	$K_v = 0.16$ cm ³	
New calculated relubrication quantity applied in the relubrication interval	$V_{Oil} = \text{round} \frac{16.67 \cdot S_{AP} \cdot K_v}{v_m \cdot t_T}$ $V_{Oil} = \text{round} \frac{16.67 \cdot 12 \cdot 0.16}{1.0 \cdot 20} = 1.6$ cm ³	According to Formula 2

Result:

The lubrication design with a piston distributor of 0.16 cm³ is **adequate**, as the necessary relubrication quantity according to Table 7 of 1.30 cm³ is exceeded during the relubrication interval.

Lubrication of the Heavy Duty Roller Rail System

Lubrication using a grease gun or a progressive feeder system

▲ Take note of “Lubrication Notes” section.

Lubricating grease

We recommend using **Dynalub 510**. For further information, see “Lubrication Notes” section.

Initial lubrication of the roller runner blocks (basic lubrication)

Stroke $\geq 2 \cdot$ roller runner block length B_1 (normal stroke)

► For initial lubrication, mount one lube fitting per roller runner block, at either of the two end caps!

Initial lubrication is applied in three partial quantities as specified in Table 10:

1. Grease the roller runner block with the first partial quantity as per Table 10, pressing it in slowly with the help of a grease gun.
2. Slide the roller runner block back and forth over at least three times the block length (size 125 at least 300 mm) for three full cycles.
3. Repeat steps 1. and 2. twice more.
4. Make sure there is a visible film of lubricant on the roller guide rail.

Stroke $< 2 \cdot$ roller runner block length B_1 (short stroke)

► Install and lubricate two lube fittings per roller runner block, one on each of the two end caps!

Initial lubrication is applied to each fitting in three partial quantities as specified in Table 10:

1. Grease each fitting on the roller runner block with the first partial quantity as per Table 10, pressing it in slowly with the help of a grease gun.
2. to 4. Repeat the procedure as for initial lubrication (normal stroke).

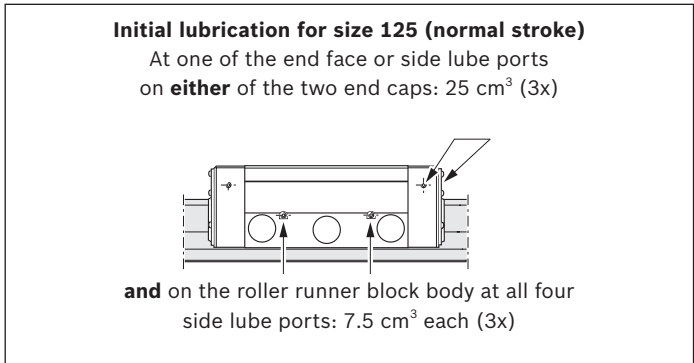

Fig. 10

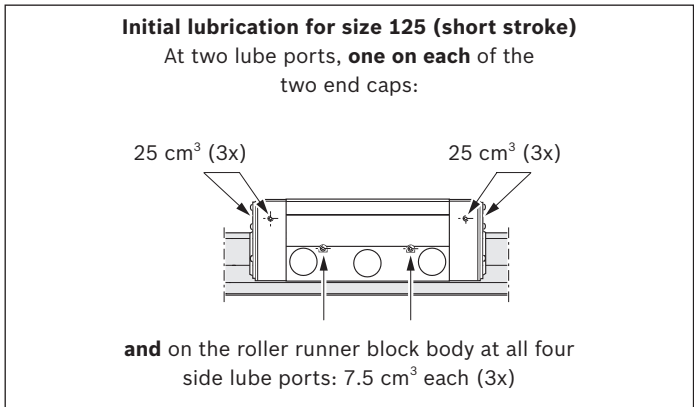

Fig. 11

Size	Initial lubrication		
	Normal stroke Partial quantity (cm ³)	Short stroke Partial quantity per port (cm ³)	
		left	right
55/85	1.8 (3x)	1.8 (3x)	1.8 (3x)
65/100 65 FXS	3.2 (3x)	3.2 (3x)	3.2 (3x)
100	15.0 (3x)	15.0 (3x)	15.0 (3x)
125	as shown in Fig. 10	Ports left, right and side as shown in Fig. 11	

Table 10

Relubrication of roller runner blocks

Stroke $\geq 2 \cdot$ roller runner block length B_1 (normal stroke)

- ▶ When the travel distance shown as the relubrication interval in Fig. 14 has been reached, apply the relubrication quantity as specified in Table 11.

Stroke $< 2 \cdot$ roller runner block length B_1 (short stroke)

- ▶ When the travel distance shown as the relubrication interval in Fig. 14 has been reached, apply the relubrication quantity as specified in Table 11 per lube port.
- ▶ During each lubrication cycle the roller runner block should be traversed through a lubricating stroke of $3 \cdot$ roller runner block length B_1 . In any case, the lubricating stroke must be at least the length B_1 of the roller runner block.

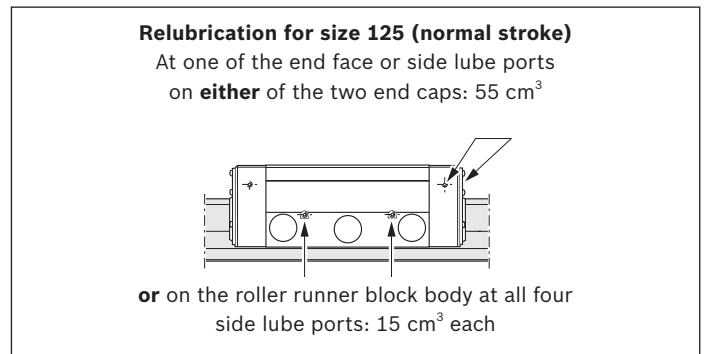

Fig. 12

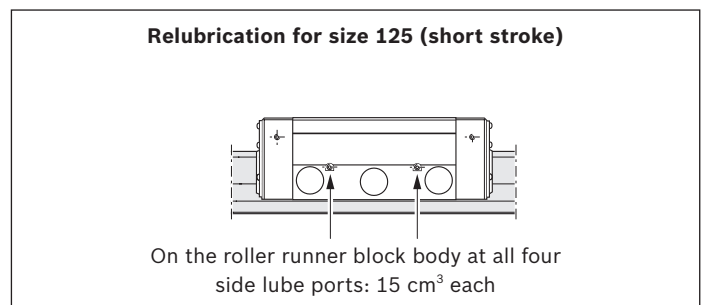

Fig. 13

Size	Relubrication		
	Normal stroke Partial quantity (cm^3)	Short stroke Partial quantity per port (cm^3)	
		left	right
55/85	1.8	1.8	1.8
65/100	3.2	3.2	3.2
65 FXS			
100	15.0	15.0	15.0
125	As shown in Fig. 12	Side ports as shown in Fig. 13	

Table 11

Load-dependent relubrication intervals ("dry axes")

The following conditions apply:

- ▶ Maximum speed: $v_{\text{max}} = 2 \text{ m/s}$
- ▶ No exposure to metalworking fluids
- ▶ Standard seals
- ▶ Ambient temperature: $T = 10 - 40 \text{ }^\circ\text{C}$

Key to graphs

- s = relubrication interval expressed as travel (km)
 C = dynamic load capacity (N)
 F = equivalent dynamic load (N)

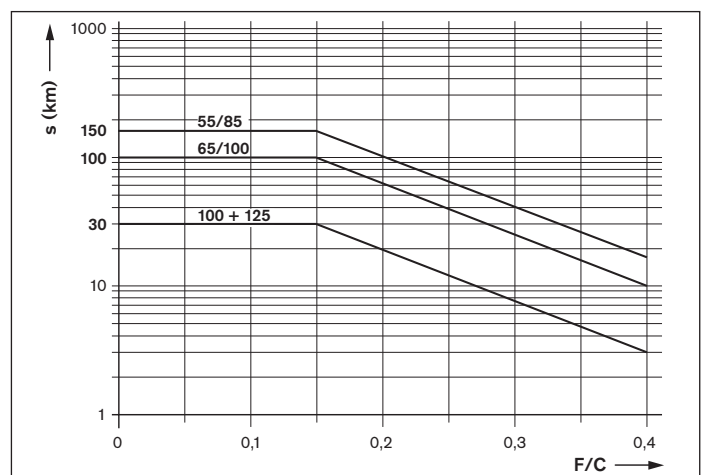

Fig. 14

Lubrication of the Heavy Duty Roller Rail System

Liquid grease lubrication via single-line piston distributor systems

▲ Take note of “Lubrication Notes” section.

Liquid grease

We recommend using **Dynalub 520**. For further information, see “Lubrication Notes” section.

Initial lubrication of the roller runner blocks (basic lubrication)

We recommend applying initial lubrication with a manual grease gun before connecting the equipment to the centralized lubrication system. If initial lubrication is nevertheless carried out via the centralized lubrication system, it is essential that all lines and piston distributors should be filled. The pulse count can then be calculated from the partial quantities and the piston distributor size according to Table 14.

Stroke $\geq 2 \cdot$ roller runner block length B_1 (normal stroke)

- For initial lubrication, mount one lube fitting per roller runner block, at either of the two end caps!

Initial lubrication is applied in three partial quantities as specified in Table 12:

1. Grease the roller runner block with the first partial quantity as per Table 12, pressing it in slowly with the help of a grease gun.
2. Slide the roller runner block back and forth over at least three times the block length (size 125 at least 300 mm) for three full cycles.
3. Repeat steps 1. and 2. twice more.
4. Make sure there is a visible film of lubricant on the roller guide rail.

Stroke $< 2 \cdot$ roller runner block length B_1 (short stroke)

- Install and lubricate two lube fittings per roller runner block, one on each of the two end caps!

Initial lubrication is applied to each fitting in three partial quantities as specified in Table 12:

1. Grease each fitting on the roller runner block with the first partial quantity as per Table 12, pressing it in slowly with the help of a grease gun.
2. to 4. Repeat the procedure as for initial lubrication (normal stroke).

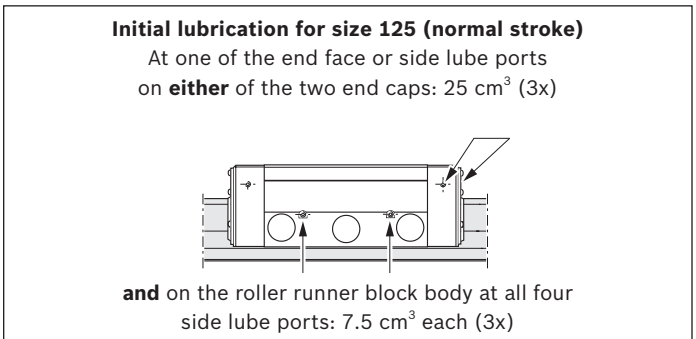

Fig. 15

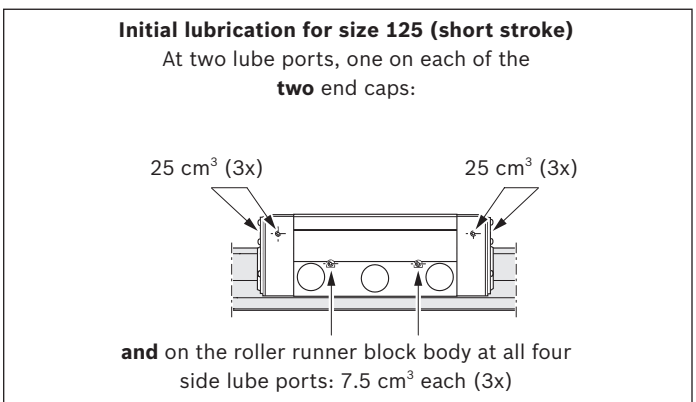

Fig. 16

Size	Initial lubrication		
	Normal stroke Partial quantity (cm ³)	Short stroke Partial quantity per port (cm ³)	
		left	right
55/85	1.8 (3x)	1.8 (3x)	1.8 (3x)
65/100 65 FXS	3.2 (3x)	3.2 (3x)	3.2 (3x)
100	15.0 (3x)	15.0 (3x)	15.0 (3x)
125	As shown in Fig. 15	Ports left, right and side as shown in Fig. 16	

Table 12

Relubrication of roller runner blocks

Stroke $\geq 2 \cdot$ roller runner block length B_1 (normal stroke)

- ▶ Apply the minimum quantity according to Table 13 to the lube port until the relubrication interval as specified (in Fig. 19) has been reached.

Stroke $< 2 \cdot$ roller runner block length B_1 (short stroke)

- ▶ Apply the minimum quantity according to Table 13 per lube port until the relubrication interval as specified (in Fig. 19) has been reached.
Calculate the required pulse count and lubricant cycle time in the same way as for relubrication (normal stroke).
- ▶ During each lubrication cycle the roller runner block should be traversed through a lubricating stroke of $3 \cdot$ roller runner block length B_1 . In any case, the lubricating stroke must be at least the length B_1 of the roller runner block.

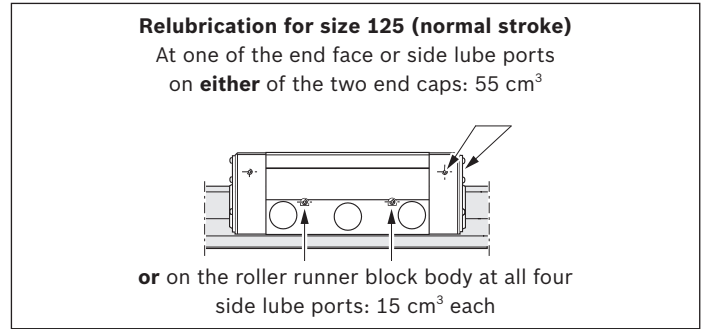

Fig. 17

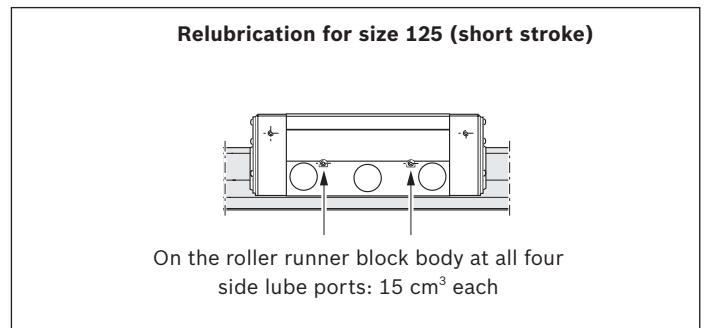

Fig. 18

Notes

The required pulse count is the quotient (as a whole number) of the minimum relubrication quantity according to Table 13 and the smallest permissible piston distributor size ($\hat{=}$ the minimum pulse quantity) according to Table 14. The smallest permissible piston distributor size also depends on the mounting orientation. The lubricant cycle time can then be obtained by dividing the relubrication interval (according to Fig. 19) by the calculated pulse count (see design calculation example).

Size	Relubrication Normal stroke (cm ³)	Short stroke per port (cm ³)	
		left	right
55/85	1.8	1.8	1.8
65/100 65 FXS	3.2	3.2	3.2
100	15.0	15.0	15.0
125	As shown in Fig. 17	Side ports as shown in Fig. 18	

Table 13

Load-dependent relubrication intervals (“dry axes”)

The following conditions apply:

- ▶ Maximum speed: $v_{max} = 2$ m/s
- ▶ No exposure to metalworking fluids
- ▶ Standard seals
- ▶ Ambient temperature: $T = 10 - 40$ °C

Key to graphs

s = relubrication interval expressed as travel (km)
C = dynamic load capacity (N)
F = equivalent dynamic load (N)

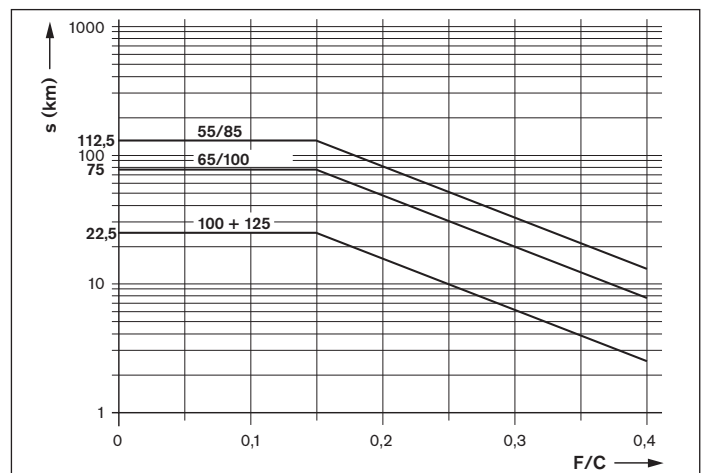
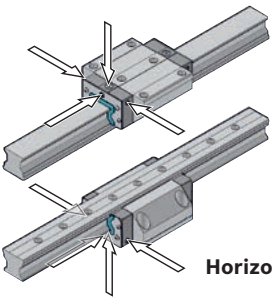

Fig. 19

Lubrication of the Heavy Duty Roller Rail System

Liquid grease lubrication via single-line piston distributor systems (continued)

Mounting orientation I – normal stroke
Horizontal
 1 lube port at **either** of the two end caps



Horizontal, top-down
 Same port

Mounting orientation II – normal stroke
Vertical to inclined horizontal
 1 lube port at top end cap

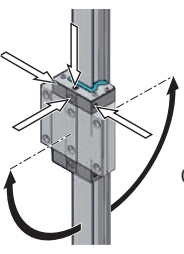

0° to max. $\pm 90^\circ$

Vertical to inclined, top-down
 Same port

Mounting orientation III – normal stroke
Wall mounting
 1 lube port at **either** of the two end caps

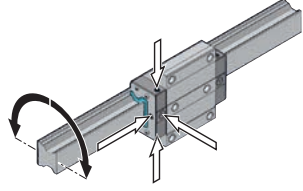

0° to max. $\pm 90^\circ$

Mounting orientation IV – short stroke
Horizontal
 2 lube ports, **one on each** of the two end caps

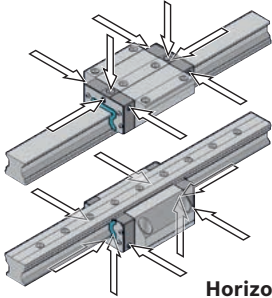

Horizontal, top-down
 Same port

Mounting orientation V – short stroke
Vertical to inclined horizontal
 2 lube ports, **one on each** of the two end caps (top and bottom)

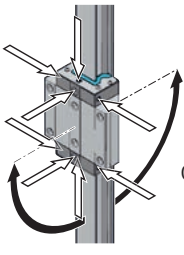

0° to max. $\pm 90^\circ$

Vertical to, top-down
 Same port

Mounting orientation VI – short stroke
Wall mounting
 2 lube ports, **one on each** of the two end caps

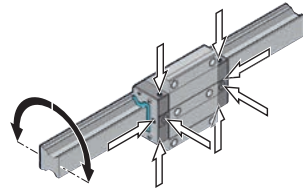

0° to max. $\pm 90^\circ$

Smallest permissible piston distributor sizes for liquid grease lubrication through single-line centralized systems¹⁾

Roller runner blocks		Smallest permissible piston distributor size (\triangleq minimum pulse quantity) per lube port (cm ³) for liquid grease, NLGI class 00			
		Size			
		55/85	65/100/65 FXS	100	125
Part numbers R18... 10 or ... 60	Mounting orientations				
	Horizontal I, IV	0.1	0.2	0.3	1.5
	Vertical II, V	0.1	0.2	0.3	1.5
Wall mounting III, VI		0.1	0.2	0.3 (2x) ²⁾	0.3 (2x) ²⁾³⁾

Table 14

- 1) The following conditions apply: Liquid grease Dynalub 520 (or Castrol Longtime PD 00, or Elkalub GLS 135/N00) and piston distributors from SKF
- 2) Sizes 100 and 125: Either two pulses in short succession or two metering valves delivering one pulse simultaneously
- 3) Size 125: 0.3 cm³ per port when all four ports in the roller runner block body are used

Lubrication of the Heavy Duty Roller Rail System

Oil lubrication via single-line piston distributor systems

▲ Take note of “Lubrication Notes” section.

Oil lubricant

We recommend using **Shell Tonna S3 M 220**. For further information, see “Lubrication Notes” section.

Initial lubrication of the roller runner blocks (basic lubrication)

We recommend applying initial lubrication with a manual grease gun before connecting the equipment to the centralized lubrication system.

Stroke $\geq 2 \cdot$ roller runner block length B_1 (normal stroke)

- For initial lubrication, mount one lube fitting per roller runner block, at either of the two end caps!

Initial lubrication is applied in two partial quantities as specified in Table 15:

1. Apply the first of the oil quantities as specified in Table 15 to the roller runner block.
2. Slide the roller runner block back and forth over at least three times the block length (size 125 at least 300 mm) for three full cycles.
3. Repeat steps 1. and 2.
4. Make sure there is a visible film of lubricant on the roller guide rail.

Stroke $< 2 \cdot$ roller runner block length B_1 (short stroke)

- Install and lubricate two lube fittings per roller runner block, one on each of the two end caps!

Initial lubrication is applied in two partial quantities per lube fitting as specified in Table 15:

1. Apply the first of the oil quantities as specified in Table 15 to the roller runner block.
2. to 4. Repeat the procedure as for initial lubrication (normal stroke).

If initial lubrication is nevertheless carried out via the centralized lubrication system, it is essential that all lines and piston distributors should be filled. The pulse count can then be calculated from the partial quantities and the piston distributor size according to Table 17.

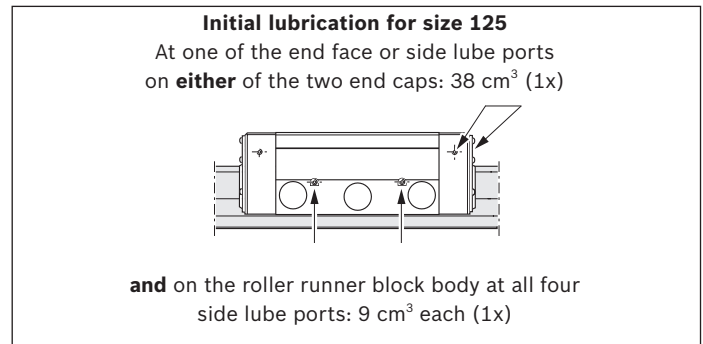

Fig. 20

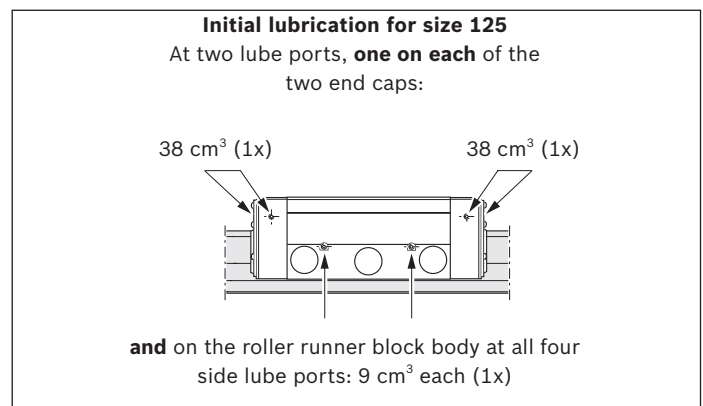

Fig. 21

Size	Initial lubrication		
	Normal stroke Partial quantity (cm ³)	Short stroke Partial quantity per port (cm ³)	
		left	right
55/85	2.7 (2x)	2.7 (2x)	2.7 (2x)
65/100 65 FXS	4.8 (2x)	4.8 (2x)	4.8 (2x)
100	11.0 (2x)	11.0 (2x)	11.0 (2x)
125	As shown in Fig. 20	Ports left, right and side as shown in Fig. 21	

Table 15

Relubrication of roller runner blocks

Stroke $\geq 2 \cdot$ roller runner block length B_1 (normal stroke)

- ▶ Apply the minimum quantity according to Table 16 to the lube port until the relubrication interval as specified (in Fig. 24) has been reached.

Stroke $< 2 \cdot$ roller runner block length B_1 (short stroke)

- ▶ Apply the minimum quantity according to Table 16 to the lube port until the relubrication interval as specified (in Fig. 24) has been reached. Calculate the required pulse count and lubricant cycle time in the same way as for relubrication (normal stroke).
- ▶ During each lubrication cycle the roller runner block should be traversed through a lubricating stroke of $3 \cdot$ roller runner block length B_1 . In any case, the lubricating stroke must be at least the length B_1 of the roller runner block.

Notes

The required pulse count is the quotient (as a whole number) of the minimum relubrication quantity according to Table 16 and the smallest permissible piston distributor size ($\hat{=}$ minimum pulse quantity) according to Table 17. The smallest permissible piston distributor size also depends on the mounting orientation.

The lubricant cycle time can then be obtained by dividing the relubrication interval (according to Fig. 24) by the calculated pulse count.

Load-dependent relubrication intervals ("dry axes")

The following conditions apply:

- ▶ Maximum speed: $v_{max} = 2$ m/s
- ▶ No exposure to metalworking fluids
- ▶ Standard seals
- ▶ Ambient temperature: $T = 20 - 30$ °C

Key to graphs

s = relubrication interval expressed as travel (km)
 C = dynamic load capacity (N)
 F = equivalent dynamic load (N)

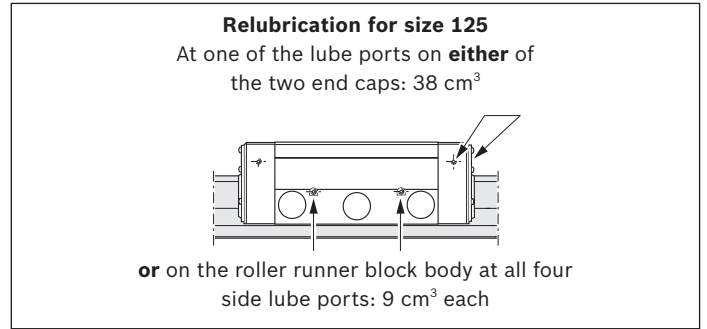

Fig. 22

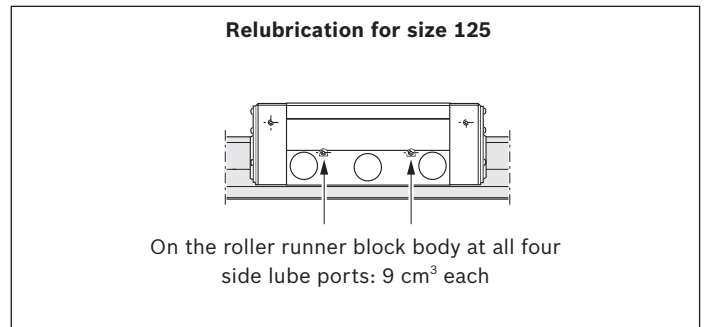

Fig. 23

Size	Relubrication		
	Normal stroke (cm³)	Short stroke per port (cm³)	
		left	right
55/85	2.7	2.7	2.7
65/100	4.8	4.8	4.8
65 FXS			
100	11.0	11.0	11.0
125	As shown in Fig. 22	Side ports as shown in Fig. 23	

Table 16

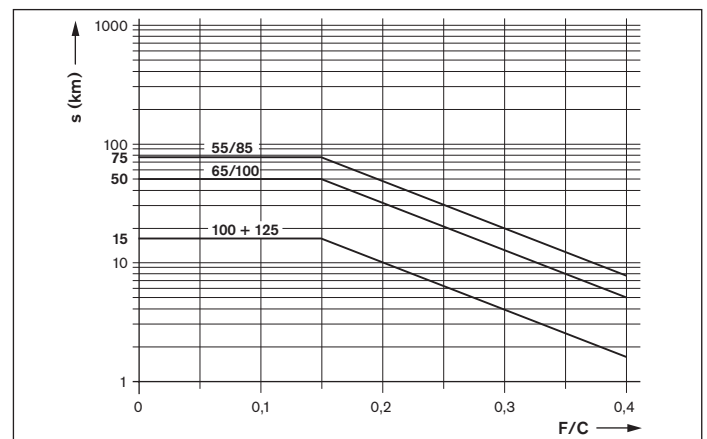
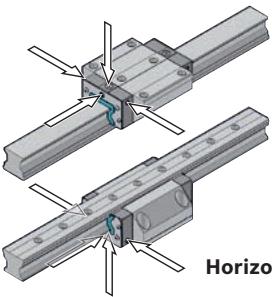

Fig. 24

Lubrication of the Heavy Duty Roller Rail System

Oil lubrication via single-line piston distributor systems (continued)

Mounting orientation I – normal stroke
Horizontal
 1 lube port at **either** of the two end caps



Horizontal, top-down
 Same port

Mounting orientation II – normal stroke
Vertical to inclined horizontal
 1 lube port at top end cap

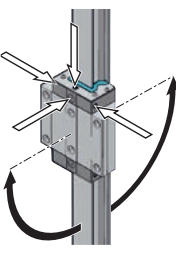

0° to max. ±90°

Vertical to inclined, top-down
 Same port

Mounting orientation III – normal stroke
Wall mounting
 1 lube port at **either** of the two end caps

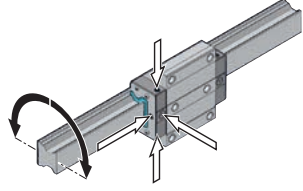

0° to max. ±90°

Mounting orientation IV – short stroke
Horizontal
 2 lube ports, **one on each** of the two end caps

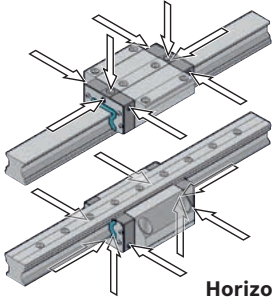

Horizontal, top-down
 Same port

Mounting orientation V – short stroke
Vertical to inclined horizontal
 2 lube ports, **one on each** of the two end caps (top and bottom)

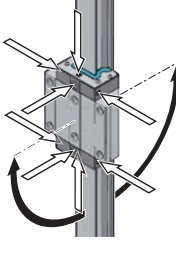

0° to max. ±90°

Vertical to inclined, top-down
 Same port

Mounting orientation VI – short stroke
Wall mounting
 2 lube ports, **one on each** of the two end caps

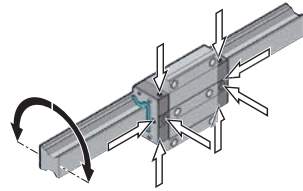

0° to max. ±90°

Smallest permissible piston distributor sizes for oil lubrication via single-line centralized systems¹⁾

Roller runner blocks		Smallest permissible piston distributor size (≧ minimum pulse quantity) per lube port (cm ³) for oil viscosity 220 mm ² /s			
		Size			
Part numbers	Mounting orientations	55/85	65/100/65 FXS	100	125
R18.. ... 10 or ... 60	Horizontal I, IV	0.6	0.6	1.5	1.5
	Vertical II, V	0.6	0.6	1.5	1.5
	Wall mounting III, VI	1.0	1.5	1.5 (3x) ²⁾	1.5 (3x) ²⁾³⁾

Table 17

- 1) The following conditions apply: Lube oil Shell Tonna S3 M 220 using piston distributors from SKF
- 2) Sizes 100 and 125: Either three pulses in short succession or three metering valves delivering one pulse simultaneously
- 3) Size 125: 1.5 cm³ per port when all four ports in the roller runner block body are used

Design example for lubrication of a typical 2-axis application with centralized lubrication
X-axis

Component or parameter	Given data
Roller runner block	Size 100; 4 blocks; C = 461,000 N; part number: R1861 223 10
Roller guide rail	Size 100; 2 rails; L = 1,500 mm; part number: R1835 263 61
Equivalent dynamic load on bearing	F = 115,250 N (per roller runner block) taking into account the preload (in this case 8% C)
Stroke	800 mm
Average linear speed	$v_m = 1 \text{ m/s}$
Temperature	20 to 30 °C
Mounting orientation	Horizontal
Lubrication	Single-line centralized lubrication system for all axes with liquid grease Dynalub 520
Exposure to contaminants	No exposure to fluids, chips, dust

Design variables	Design input (per roller runner block)	Information sources
Normal or short-stroke	Normal stroke: $\text{Stroke} \geq 2 \cdot \text{roller runner block length } B_1$ $800 \text{ mm} \geq 2 \cdot 204 \text{ mm?}$ $800 \text{ mm} \geq 408 \text{ mm!}$ i.e. normal stroke applicable!	Normal stroke formula from catalog, B_1 from catalog
Initial lubrication quantity	Initial lubrication quantity: 15.0 cm^3 (3x)	Initial lubrication quantity from table
Relubrication quantity	Relubrication quantity: 15.0 cm^3	Relubrication quantity from table
Mounting orientation	Mounting orientation I – normal stroke (horizontal)	Mounting orientation from catalog
Piston distributor size	Permissible piston distributor size: 0.3 cm^3	Piston distributor size from table for size 100, mounting orientation I
Pulse count	$\text{Pulse count} = \frac{15.0 \text{ cm}^3}{0.3 \text{ cm}^3} = 50$	$\text{Pulse count} = \frac{\text{Relubrication quantity}}{\text{Perm. piston distributor size}}$
Load ratio	$\text{Load ratio} = \frac{115,250 \text{ N}}{461,000 \text{ N}} = 0.25$	$\text{Load ratio} = \frac{F}{C}$ F and C from given data in catalog
Relubrication interval	Relubrication interval: 10 km	Relubrication interval from figure Curve size 100 at load ratio 0.25
Lubrication cycle	$\text{Lubrication cycle} = \frac{10 \text{ km}}{50} = 0.2 \text{ km}$	$\text{Lubrication cycle} = \frac{\text{Relubrication interval}}{\text{Pulse count}}$

**Interim result
(X-axis)**

Every 0.2 km a minimum quantity of 0.3 cm^3 Dynalub 520 must be supplied to the roller runner block on the X-axis.

Lubrication of the Heavy Duty Roller Rail System

Design example for lubrication of a typical 2-axis application with centralized lubrication (continued)

Y-axis

Component or parameter	Given data
Roller runner block	Size 65/100; 4 blocks; C = 265,500 N; part number: R1851 323 10
Roller guide rail	Size 65/100; 2 rails; L = 1,500 mm; part number: R1875 663 61
Equivalent dynamic load on bearing	F = 66,375 N (per roller runner block) taking into account the preload
Stroke	300 mm
Average linear speed	$v_m = 1$ m/s
Temperature	20 to 30 °C
Mounting orientation	Vertical
Lubrication	Single-line centralized lubrication system for all axes with liquid grease Dynalub 520
Exposure to contaminants	No exposure to fluids, chips, dust

Design variables	Design input (per roller runner block)	Information sources
Normal or short-stroke	Normal stroke: Stroke $\geq 2 \cdot$ roller runner block length B_1 $300 \text{ mm} \geq 2 \cdot 194 \text{ mm}?$ $300 \text{ mm} < 388 \text{ mm}!$ i.e. short stroke applicable!	Normal stroke formula from catalog, B_1 from catalog
Initial lubrication quantity	2 lube ports, initial lubrication quantity per lube port: 3.2 cm^3 (3x)	Initial lubrication quantity from table
Relubrication quantity	2 lube ports, relubrication quantity per port: 3.2 cm^3	Relubrication quantity from table
Mounting orientation	Mounting orientation V – short stroke (vertical)	Mounting orientation from catalog
Piston distributor size	Permissible piston distributor size: 0.2 cm^3	Piston distributor size from table for size 65/100, mounting orientation V
Pulse count	Pulse count = $\frac{3.2 \text{ cm}^3}{0.2 \text{ cm}^3} = 16$	Pulse count = $\frac{\text{Relubrication quantity}}{\text{Perm. piston distributor size}}$
Load ratio	Load ratio = $\frac{66,375 \text{ N}}{265,500 \text{ N}} = 0.25$	Load ratio = $\frac{F}{C}$ F and C from given data in catalog
Relubrication interval	Relubrication interval: 30 km	Relubrication interval from figure Curve size 65/100 at load ratio 0.25
Lubrication cycle	Lubrication cycle = $\frac{30 \text{ km}}{16} = 1.875 \text{ km}$	Lubrication cycle = $\frac{\text{Relubrication interval}}{\text{Pulse count}}$

Interim result (Y-axis)

Every 1.875 km a minimum quantity of 0.2 cm^3 Dynalub 520 must be supplied to the roller runner block on the Y-axis.

End result (two-axis lubrication)

Since both the axes in this example are supplied by a single-line centralized lubrication system, the X-axis with its smaller lube cycle (0.2 km) determines the overall cycle of the system, i.e. the Y-axis will also be lubricated every 0.2 km.

The number of ports and the minimum lubricant quantities determined for each axis remain the same.

Subsequent opening of a lube hole at the top for heavy duty roller runner blocks sizes 100 and 65 FXS

If a lube hole is to be opened up at the top of heavy duty roller runner blocks, the following points should be noted:

- ⚠ In the O-ring recess there is a further pre-formed small recess (5). Do not use a drill to open this. Risk of contamination!
- ▶ Heat up a pointed metal punch (4) with diameter of 1.5 mm.
- ▶ Carefully punch through the recess (5) to open the lube hole.
Do not exceed the permissible depth T_{max} as specified in the table!
- ▶ Insert O-ring (2) in the recess (O-ring is not supplied with the roller runner block).

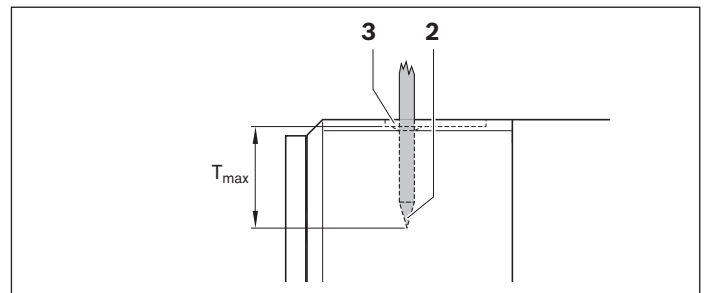
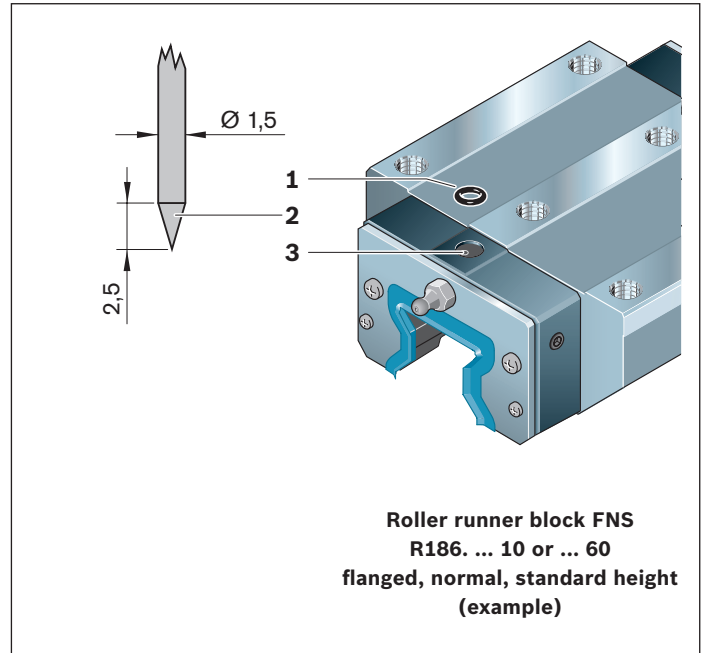

Size	Lube hole at top: Maximum permitted depth for punching open T_{max} (mm)
65 FXS, 100	5

Maintenance

Cleaning cycle

Dirt can settle and encrust on roller guide rails, especially when these are not enclosed.

To ensure that seals and cover strips retain their functionality, this dirt must be removed at regular intervals.

It is advisable to run the machine through at least one full cleaning cycle over the entire installed rail length every 8 hours.

Depending on the amount of soiling and on the coolant used, more frequent cleaning may be required.

Before shutting down the machine, always apply 3 lubrication pulses or lubrication strokes. The lubrication pulses should be applied during the movement of the axis over the largest possible travel (cleaning cycle).

Maintenance of accessories

All accessories used for scraping or wiping the roller guide rails must be checked at regular intervals.

In environments with heavy contamination, it is advisable to replace all the parts directly exposed to such contamination.

We recommend checking the accessories at least once a year.

Bosch Rexroth AG

Ernst-Sachs-Straße 100
97424 Schweinfurt, Germany
Tel. +49 9721 937-0
Fax +49 9721 937-250
www.boschrexroth.com

Find your local contact person here:

www.boschrexroth.com/contact

The data specified above only serve to describe the product.

As our products are constantly being further developed, no statements concerning a certain condition or suitability for a certain application can be derived from our information. The information given does not release the user from the obligation of own judgment and verification. It must be remembered that our products are subject to a natural process of wear and aging.